

**HLL LIFECARE LTD
(A Government of India Enterprise)
CENTRAL ENGINEERING DIVISION
P.B.NO.2, PEROORKADA P.O.,
THIRUVANANTHAPURAM - 695 005
KERALA, INDIA**

**INVITATION FOR BID (IFB)
(TECHNICAL BID)**

FOR

**SUPPLY, INSTALLATION, INTEGRATION,
TESTING AND COMMISSIONING OF ON LINE
VULCANISING TUMBLERS IN PAIR FOR THE
BTADL CONDOM DIPPING MACHINE AT
IRAPURAM.**

IFB NO. : HLL/CED/CON-AUG/SIITC/VUL.TUMBLER/BTADL CDM/2013

DATE: 11-10-2013

**HLL LIFECARE LIMITED
(A Government of India Enterprise)
CENTRAL ENGINEERING DIVISION
THIRUVANANTHAPURAM-695 005**

INVITATION FOR BIDS (IFB)

IFB NO. : HLL/CED/CON-AUG/SIITC/VUL.TUMBLER/BTADL CDM/2013

DATE: 11-10-2013

HLL Lifecare Limited (HLL) invites sealed and super scribed bids from competent and experienced eligible Suppliers/Contractors for the supply of following item in connection with the Condom Capacity Augmentation Project at our Irapuram Factory in Kerala.

Sl. No	Brief Description of Item	Quantity	EMD Amount in Rs
1	Supply, Installation, Integration, Testing and Commissioning of On Line Vulcanising Tumblers in pair for the BTADL Condom Dipping Machine a tour factory in Irapuram, Kerala	As per schedule of items	Rs. 10,000/-

CONTENTS OF BIDDING DOCUMENTS

I. INSTRUCTION TO BIDDERS:

1. A complete set of bid documents can be had from the Office of the Associate Vice President (CED), Central Engineering Division, HLL Lifecare Limited, Peroorkada Factory, Thiruvananthapuram – 695 005, Kerala, India during office hours on any working day on submission of written application.

The Tender Documents can also be downloaded from our Website www.lifecarehll.com and the Central Public Procurement Portal of Government of India www.eprocure.gov.in from the date of issue of tender document. Tender forms shall be filled in ink or typed. No tender filled in pencil shall be considered. The tenderer shall sign and seal the form at each page and at the end, in token of acceptance of all the terms and conditions of the tender.

2. The bid documents will be available up to 15.00 Hrs. on the previous working day of the opening of the bids.

3. The scheduled date for issue, receipt and opening of bids is as follows.

- a) Date of issue of tender document - 11-10-2013 onwards.
- b) Last date and time for receipt of bids - 23-10-2013 up to 15.00 Hrs.
- c) Date and time of opening of bids - 23-10-2013 , 15.30 Hrs.
- d) Address for communication, receipt and place of opening of bids:

Associate Vice President (CED)
Central Engineering Division,
HLL Lifecare Limited (A Government of India Enterprise),
PB No 2, Peroorkada, Thiruvananthapuram – 695005,
Kerala State, India
Ph: (++91 471) 2433374,2437270 –501,502
Tele Fax: (++ 91 471) 2432647
E-mail: srnair@lifecarehll.com, rajeevrv@lifecarehll.com.

4. The completed and sealed bid documents and all schedules should be submitted to Associate Vice President (CED) in the above address along with the EMD. Bids received after due date and time will be rejected. Any bid not accompanied by EMD will not be considered.

5. Bidders shall submit their bids in two parts (TECHNICAL BID and PRICE BID) as under.

6. Technical bid, clearly marking consisting of the deviations in specifications if any, and also clause-by-clause compliance of Technical Bid evaluation criteria, specifications and commercial terms and conditions and EMD, in separate sealed covers super scribing "Technical Bid" inside a main cover.

7. Price bids, clearly marking, showing only item wise rates and total prices in sealed covers super scribing "Price Bid" inside a main cover.

5. **Earnest Money**

5.1 Each bid must be accompanied by E.M.D.

5.2 The EMD is required to protect the Owner against risk of Bidder's conduct, which would warrant the security's forfeiture

- a. The EMD shall be in the form of Demand Draft from a nationalized bank drawn in favour of HLL Lifecare Limited, Thiruvananthapuram payable at Thiruvananthapuram.

- b. E.M.D. of the unsuccessful bidders will be released after tabulating tenders, keeping only the earnest money of the first three lowest bidders. The earnest money deposit of the remaining two unsuccessful bidders will be released after the acceptance of the notification of award by the successful bidder.
- c. In the case of successful bidder, the Earnest Money will be returned after signing the agreement and submission of Demand Draft towards Security Deposit, which they will have to offer for the faithful execution of the contract.

5.3 The EMD may be forfeited:

- (a) If a Bidder withdraws its bid during the period of bid validity specified by the Bidder on the Bid Document; or
- (b) In case of the successful Bidder, if the Bidder fails:
 - (i) to sign the agreement.
 - (ii) to furnish security deposit.
 - (iii) does not accept the correction of his bid price pointed out by HLL

5.4 The EMD should be enclosed in a separate envelope and superscribed as "EMD" and to be attached in the main cover.

- 6 Bids will be opened in the presence of Bidders representative(s) who choose to attend on the specified date and time, at the office of HLL at the address given in Clause '3 (d)' above.
- 7 In the event of the date specified for bid receipt and opening being declared as a closed holiday for Owner's office, the due date for submission of bids and opening of bids will be the following working day at the appointed times.
- 8 The Owner may, at its discretion, extend this deadline for submission of bids by amending the Bid Documents or any other reasons, in which case all rights and obligations of the Owner and Bidders previously subject to the deadline will thereafter be subject to the deadline as extended.
- 9 Owner will not be held responsible for the postal delay, if any, in the delivery of the bidding document or the non-receipt of the same. Bids sent by Telex/Fax/Telegraph will not be accepted.
- 10 The company reserves the right to club or split the supply of items , change the qualifying criteria at their discretion and to reject or cancel the Invitation for bids without assigning any reason thereof.

ASSOCIATE VICE PRESIDENT (CED)

II. TECHNICAL BID FORMS

1. Schedule A - Specifications
2. Schedule B - Prequalification Requirements
3. Schedule C - Application for Prequalification
4. Schedule D - Details of major supply of similar item supplied successfully by the tenderer as during the last 5 years Details of recent orders
5. Schedule E - Details of ongoing purchase orders
6. Schedule F - Acceptance form
7. Schedule G - Terms and conditions
- 8.. Schedule H - Certificate
9. Schedule I - Price Schedule

III. PRICE BID FORMS

SCHEDULE – I PRICE SCHEDULE

SCHEDULE –A

SPECIFICATIONS

Requirement

HLL require On Line Vulcanising Tumblers in pair for the Butterfly Type Automatic Double Line Condom Dipping Machine a tour factory in Irapuram, Kerala

Specifications

Item: As per drawing no.

- 1.HLL-CED-C2-001-00(ASSEMBLY OF TUMBLER)
- 2.HLL-CED-C2-002-00(DRUM FOR WASHING)
- 3.HLL-CED-C2-003-00(STRUCTURE FOR TUMBLER)
- 4.HLL-CED-C2-004-00(PARTS FOR TROLLEY OF VULCANISING TUMBLER)
- 5.HLL-CED-C2-005-00(BLOWER FOR TUMBLER)

Vulcanising Item:

Natural Rubber Latex Male Contraceptive Condoms as per ISO 4074.

DETAILS

1. SUPPLY OF AUTOMATIC ONLINE VULCANISING TUMBLER AND ACESSORIES AS PER GA DRAWING NO.HLL-CED-C2—001-00 CAPABLE OF RECEIVING OF PARTIALLY DRY CONDOMS AT THE RATE OF 170 TO 240 PCS PER MIN CONTINUOUSLY IN BATCH FOR A DURATION OF 45 MINUTES.
2. A PLC BASED AUTOMATION PACKAGE WITH MANUAL OVERRIDE FOR THE INTEGRATION OF THE ONLINE VULCAINSING TUMBLER AND ACESSORIES TO COMPLETE THE VULCANISING OF CONDOMS RECEIVED THROUGH TWO HOSES PNEUMATICALLLY CONVEYED FROM THE BUTTERFLY TYPE AUTOMATIC DOUBLE_LINE CONDOM

DIPPING MACHINE DEHYDRATOR. THE SYSTEM SHOULD BE FLEXIBLE TO UPGRADE AND POSSIBILITY OF MULTIVENDOR FACILITY INCORPORATED.

3. THE WORKS INVOLVED ARE INCLUSIVE OF SUITABLE DESIGN, INTEGRATION, AND SYNCHRONISATION OF THE SYSTEM TO FULFIL ONLINE VULCAINSING OF CONDOMS RECEIVED FROM CONDOM DIPPING MACHINE DEHYDRATOR. ALL ELECTRICAL AND ELECTRONIC COMPONENTS SHOULD AS PER G A **DRAWING NO. HLL-CED-C2-001-00** AND AUTOMATION OF THE SYSTEM WITH SUITABLE MONITORING AND CONTROL SYSTEMS AT PURCHASER'S SITE.
4. **DRIVE SYSTEM:** IT CONSISTS OF 2 nos DIRECT DRIVEN MOTORISED GEARBOX HOLLOW SHAFT(UNDER THE SCOPE OF HLL) ABLE TO DRIVE ROTATING DRUM OF VULCANISING TUMBLER IN BOTH FORWARD AND REVERSE DIRECTION(VFD ENABLED). THIS WILL CATER THE EXACT NEEDS OF THE ONLINE VULACINISING PROCESS OF LOADING, VULACANISING, QUENCHING AND UNLOADING IN THE PNEUMATICALLY ACTUATED TRAY PROVIDED FOR THE SAME. ROTATING DRUM AS PER DRAWING IS TO BE DULY BALANCED FOR FORWARD AND REVERSE DIRECTIONS AT 32 RPM. SUITABALE MOTORISED GEAR WITH HOLLOW OUTPUT SHAFT, SHOULD BE ABLE TO DRIVE TORQUE OF 500 N.M AND MOTOR POWER 2 KW MOTORISED GEAR SHOULD BE WITH SUITABLE REDUCTION RATIO, LIFE LUBRICATED AND MAINTENANCE FREE.
5. **LOADING SYSTEM:** THIS CONSISTS OF A DIVIDING DAMPER WITH PNEUMATIC ACTUATOR (SCOPE OF HLL) WITH TIMER FOR BATCH VULCANISING IN THE INTERVAL OF 45 MINUTES LOADING IN EACH TUMBLER. A STATIONARY STAINLESS STEEL (AISI 316L) PIPE CAPABLE OF CONVEYING PARTIALLY DRIED CONDOMS IN TO THE VULCANISNISING DRUM. THE TUMBLER AS PER VESSEL MADE OF STAINLESS STEEL WHICH IS ROTATING IN THE OPPOSITE DIRECTION OF THE ROTATION OF THE DRIVE SYSTEM FOR DYNAMIC FINGER MOVEMENT.

6. **HOT AIR FLOW:** THIS IS TO FACILITATE THE DUE COMPLETION OF VULCANISING PROCESS OF THE BATCH DURING ROTATION OF THE DRUM. HOT AIR BLOWER OF SUITABLE CAPACITY AND ELECTRICAL HEAT BANK WITH PROPER CONTROLS ARE TO BE PROVIDED AS PER GA DRAWING NO. **HLL-CED-C2-001-00**. BLOWER RPM:3000, MOTOR :1.5KW, IP55 PROTECTED,CLASS-F INSULATION TEFC EEF2 MOTOR MAKE:LENZE/SEW/ABB/CROMPTON GREEVES/SIEMENS
7. **UNLOADING SYSTEM:** THE VULCANISING DRUM SHOULD BE DESIGNED IN SUCH A WAY THAT, DURING VULCANISING DRUM SHOULD ROTATE IN CLOCKWISE DIRECTION AND DURING UNLOADING DRUM SHOULD ROTATE IN ANTICLOCKWISE DIRECTION. PLC SHOULD CATER THIS REQUIREMENT IN THE PANNEL. THE ROTATING DRUM DOORS ARE TO BE PROPERLY AIR TIGHT SEALED FOR OPERATING FORWARD AND REVERSE ROTATION.
8. **TRANSFERRING OF HALF FINISHED PRODUCT:** IN ORDER TO ENABLE THE TRANSFERRING OF HALF PRODUCT AFTER VULCANISING, PNEUMATIC ACTUATED TROLLEY WITH CRATE SHOULD BE PROVIDED. THIS SYSTEM SHOULD HELP TO TRANSFER THE HALF PRODUCT DULY WITH INTEGRATED CONTROLS IN THE PLC(MAKE - Schneider/ A-B/ Pepperl& Fuchs / Sprecher+ Schuh/ Siemens/L&T)
9. PLC AND HMI PANEL CONTROL SYSTEM: ALL THE COMPONENTS LIKE SENSORS, TIMERS,MOTOR CONTROLLERS,TEMPERATURE CONTROLS, TEMPERATURE SWITCHES, SOLENOID OPERATED VALVES, WIRING AND HARDWARES AND SOFTWARES WILL BE INCORPORATED TO CARRY OUT THE COMPLETE VULCANISING PROCESS. PROCESS PARAMETERS SETTING AND LAYOUT ARE SHOWN IN **ATTACHMENT SHEET - I**
10. THE MATERIAL USED IN THE PATHS AND CONTACT PARTS SHOULD BE PERFECTLY IN CONFORMANCE TO ELIMINATE HANDLING

DAMAGE TO THE NATURAL RUBBER PRODUCT AND AS PER WHO GMP STANDARDS.

11. STANDARD ENGINEERING MATERIALS SHOULD ONLY BE USED IN THE CASE OF OTHER COMPONENTS USED FOR THE MECHANISM USED IN THE INTEGRATION OF THE SYSTEM WITH ELECTRONIC TESTING MACHINE.
12. ALL CONTROLLERS SHOULD BE SUITABLE FOR WITHSTANDING POWER FLUCTUATIONS AND WITH SOFT STARTING TECHNOLOGY.
13. PNEUMATIC CONTROL VALVES AND OTHER ACTUATORS ARE TO BE OF SUITABLE DESIGN WITH THE SPACE LIMIT MENTIONED AND AS PER GA DRAWING NO. **HLL-CED-C2-001-00**.
14. NECESSARY PAINTING/POWDER COATING WORKS SUITABLE FOR DUSTY AND HOT ENVIRONMENT AS PER STANDARD NORMS.
15. SUITABLE SENSING AND CONTROL SYSTEM SHOULD BE PROVIDED FOR COMPLETEING THE VULCANISING PROCESS. STATIC ELECTRICITY DISCHARGERS SHOULD BE PROVIDED WHEREVER NECESSARY.
16. RATE SHOULD BE QUOTED SEPARATELY FOR SUPPLY AND SERVICE LIKE INTEGRATION, TESTING AND COMMISSIONING OF ONE SUCH SYSTEM AS PER PRICE SCHEDULE .BILL OF MATERIALS SHOULD BE PROVIDED SEPARATELY IN SUPPORT TO THE SUPPLY.
17. COMMISSIONING: COMMISSIONING OF THE SYSTEM OR ANY PART THEREOF SHALL BE COMMENCED BY THE BIDDER IMMEDIATELY AFTER RECEIPT OF INTIMATION FROM HLL. HLL SHALL SUPPLY THE OPERATING PERSONNEL AND ALL RAW MATERIALS, UTILITIES, LUBRICANTS, CHEMICALS SERVICES AND OTHER MATTERS REQUIRED FOR COMMISSIONING.
18. **PERFORMANCE TEST:** THE PERFORMANCE TEST SHALL BE CONDUCTED BY THE BIDDER DURING THE COMMISSIONING OF THE SYSTEM TO ASCERTAIN WHETHER THE SYSTEM CAN ATTAIN THE FUNCTIONAL GUARANTEES SPECIFIED IN THE TECHNICAL SPECIFICATION.

19. **OPERATIONAL ACCEPTANCE:** OPERATIONAL ACCEPTANCE SHALL OCCUR IN RESPECT OF THE SYSTEM WHEN THE PERFORMANCE TEST HAS BEEN SUCCESSFULLY COMPLETED AND THE FUNCTIONAL PERFORMANCES ARE MET.
20. PERIOD WARRANTY SHALL BE 12 MONTHS FROM THE DATE OF INSTALLATION AND COMMISSIONING AS CERTIFIED JOINTLY BY THE SUPPLIER AND THE PURCHASER.
21. THE BIDDER SHALL ATTEND THE PRE-BID CONFERENCE ARRANGED BY HLL BEFORE SUBMITTING THE OFFER.
22. THREE COPIES OF INSTRUCTION/OPERATIONAL MANUAL (ESPECIALLY FOR BROUGHT OUT ITEMS) AND MAINTENANCE MANUAL SHOULD BE SUPPLIED ALONG WITH THE MACHINE.
23. A LIST OF SPARE PARTS SHOULD BE PROVIDED. A MINIMUM SET OF SPARE PARTS SHOULD BE PROVIDED FOR EACH MACHINE.
24. BROUGHT OUT ITEMS SUCH AS ELECTRICAL/ELECTRONIC ITEMS, ELECTRIC HEAT BANKS ETC SHOULD BE AS PER RELEVANT INDIAN STANDARDS APPROVED CERTIFICATIONS.

SCHEDULE -B

PREQUALIFICATION REQUIREMENTS

1. The tenderer should have minimum 5 years experience in the relevant field.
2. The tenderer should have completed at least two purchase orders similar in nature in single contracts – in the same name and style as prime supplier/manufacturer) costing not less than Rs.10 lakhs during the last 2 years. For the purpose of this clause.
 - a) 'Similar work' shall mean preferably the supply, installation, testing and commissioning of Tumbler, Washing machines etc for manufacturing plants. Cost of work shall mean the cost of work order executed. Certificate of satisfactory completion of work obtained from an officer not below the rank of an executive engineer in the case of Government departments or from an officer of equivalent position in the case of other organization shall be produced. The certificate will clearly indicate the name of item supplied, period during which completed (giving date of commencement and date of completion of cost of supply). The certificate should bear the name, signature and seal of the officer. In the absence of such a certificate the tender may not be considered.
3. Average annual financial turn over of the bidder during the last 3 years, ending 31st March of the previous financial year, should be furnished.
4. The tenderer should submit Earnest Money Deposit in the manner specified along with the tender document.
5. Power of Attorney in case an authorized representative has signed the tender.
6. The duly signed acceptance form conforming that All terms & conditions, technical specifications, drawings & volume of supply are understood by the bidder. Certificate that bid is in total conformity with the specifications and terms and conditions mentioned in the bid document and certificate on period of validity (sheet enclosed)
7. Deviation if any, giving reasons for the deviation.
8. Even though the bidder meet the above qualifying criteria, they are subject to be disqualified if they have:
 - Record of poor performance such as rejection of supply, delay in delivery date stipulated, litigation history, or financial failures etc...

SCHEDULE – C

APPLICATION FOR PREQUALIFICATION

**NAME OF WORK : SUPPLY, INSTALLATION, INTEGRATION,
TESTING AND COMMISSIONING OF ON LINE VULCANISING
TUMBLERS IN PAIR FOR THE BTADL CONDOM DIPPING
MACHINE AT IRAPURAM**

- A. Name of Firm/Company :
1. Postal address :
2. Telephone No :
FAX :
E-Mail :
3. Year of commencement of Contract/
Year of establishment of firm/Company :

B. In the case of Firm

1. Whether proprietary of partnership firm:
2. Name of Managing partner :
3. Name of other partners :

Note: Attested copy of partnership deed to be enclosed

C. In the case of Company

1. Whether Private Limited or Public Limited
Company :
2. Name of Managing Director :
3. Name of other Directors :

Note: Attested copy of Company Registration deed to be enclosed.

- D. No. of major supplies of similar item supplied successfully in India, specify.
Enclose two completion certificates from the client certified that the
similar item supplied successfully. The client list shall be enclosed.

Note: Details to be furnished in **SCHEDULE -D**

- E. Has the Supplier/Firm/Company ever been black listed by the Govt/or the
registering authority.

- i) if so, give the period and details.
- F. Average annual financial turn over of the bidder during the last 3 years, ending 31st March of the previous financial year..
- a. Annualised turn over of the Contractor/Firm/Company in the last 3 years ending 31.03.2013
1. 2010-2011: Rs
 2. 2011-2012: Rs
 3. 2012-2013: Rs

(Bio data with willingness letters to be enclosed in **SCHEDULE -C**)

G. Acceptance Form in **SCHEDULE – F**

H. CERTIFICATE as per **SCHEDULE - H**

I/We hereby certify that the details given in the application form is correct to the best of my/our knowledge. I /We have no objection in contacting any of our clients for reference.

Signature:

Place:

Date:

Name and address of the bidder with seal:

SCHEDULE - D

DETAILS OF MAJOR WORK ORDER SUCCESSFULLY EXECUTED BY THE TENDERER AS PRIME CONTRACTOR DURING THE LAST 3 YEARS				
Sl. No.	Name of Client with full address, telephone numbers and nature of item supplied	Details of item supplied	Value of items supplied (in lakhs)	Period of Completion with dates (in months)

SIGNATURE OF BIDDER WITH SEAL

SCHEDULE - E

DETAILS OF ONGOING WORK ORDERS OF SIMILAR NATURE			
Sl. No.	Name of Client with full address, telephone numbers and nature of item	Description of work	Value of purchase order (in lakhs)

SIGNATURE OF BIDDER WITH SEAL

SCHEDULE – F
ACCEPTANCE FORM

(To be submitted in the letter pad of the firm indicating full name and address, telephone & fax numbers etc.)

From

To

Associate Vice President (CED)
Central Engineering Division,
HLL Lifecare Limited (A Government of India Enterprise),
PB no 2, Peroorkada, Thiruvananthapuram – 695005,
Kerala State, India
Ph: (++91 471) 2433374,2437270 –501,502
Tele Fax: (++ 91 471) 2432647
E-mail: smair@lifecarehll.com, rajeevrv@lifecarehll.com.

Dear Sir,

I / We, hereby offer to supply as detailed in schedule hereto or such portion thereof as you may specify in the acceptance of Bid at the price given in the price bid and agree to hold this offer open for 90 days from the date of bid opening prescribed by the Purchaser. I/We have understood the terms and conditions mentioned in the invitation for bid and Conditions of Contract furnished by you and have thoroughly examined the specifications quoted in the bid document hereto and are fully aware of the nature of the scope of supply of item required and my/our offer is to comply strictly in accordance with the requirement and the terms and conditions mentioned above.

The following pages have been added to and form part of this bid.

Yours faithfully,

SIGNATURE OF THE BIDDER WITH SEAL

SCHEDULE – G

TERMS & CONDITIONS

1. The Tender should be completed in all respects. Incomplete tenders are liable to be rejected.
2. Unsealed Tenders received are liable to be rejected and this will be at the sole risk of the Tenderer.
3. The tender is liable to be suspended or cancelled at anytime at the discretion of the company without assigning any reason.

In the event of placing orders: -

- a. In tenderer shall return one copy of order signed and sealed as a token of acceptance.
- b. (i) In case of rejection, the equipment should be taken back and replaced at yours risk and cost within 7 days of intimation from HLL.

(ii) Equipment shall be returned back to you through the Transporter indicated by you.
- c. The SUPPLIER/AUTHORISED DEALER agrees to supply strictly as per the order terms in respect of quality and specification. HLL reserves the right not to receive the goods beyond the delivery date given in the order.

4. PRICE

The price quoted should be inclusive of Basic Price, all applicable taxes and duties including VAT, Entry tax, Octroi & other levies, P&F charges, loading and unloading charges, insurance, etc. The Supplier should pay entry taxes, as applicable and should be included in the offer.

The Price Schedule (Schedule I) shall be suitably filled as applicable. The quoted rate shall be valid for a period of 31st March 2014. No price escalation and no change in terms and conditions will be allowed on any ground till the order is completely executed.

5. TAXES/DUTIES/LEVIES

The supplier shall be entirely responsible for all taxes including entry tax, duties, license fees, etc. incurred until successful completion of contract. All central, state, municipal taxes, duties and levies payable shall be shown by the bidder separately in the Bid. The Purchaser will issue necessary 'C' Form, if required.

6. COMPLETION TIME

- a. The item should be delivered within **5 WEEKS** from the date of issuing the Letter of Intent or Supply Order.
- b. The quantity mentioned herein are approximate requirement with staggered delivery.
- c. In case less or more quantity is required the suppliers should be prepared to effect supply at short notice on the same terms and conditions.
- d. The following documents should accompany the consignment
 - i) Invoice in triplicate bearing Supply Order No. & date
 - ii) Delivery Note/Challan
 - iii) Packing List
 - iv) LR No.

7. GUARANTEE PERIOD

The Guarantee against any possible manufacturing defects shall be given for a period of 18 months from the date of supply and inspection of the item at HLL site or 12 months from the date of supply, whichever is earlier.

8. LIQUIDATED DAMAGES FOR DELAY

The parties have to abide by delivery schedule given in the supply order strictly. Penalty for delay @ 0.5% value of the materials per week of delay subject to a maximum of 7.5% of the value of the supply order will be imposed, if equipment is accepted by the Company after the stipulated delivery period.

9. PAYMENT TERMS :-

1. 60% of the payment on pro-rata basis shall be released after satisfactory installation, integration, testing and trial run of Online tumbler vulcanizing and satisfactory continuous operation for a period of 7 days.
2. Balance 30% of the payment on pro-rate basis shall be released within 45 days of satisfactory continuous operation for 2 shift operation/days (16 hrs) / 45 days validation, performance evaluation in terms of quality, quantity and commissioning, and final acceptance certificate issued by the competent authority.
3. The balance 10% payment shall be released against a Performance guarantee valid for a period of one year from the date of the issue of final acceptance certificate of the entire system.

The jurisdiction of any disputed, suits and proceedings arising out of this tender shall be only in the court of Thiruvananthapuram.

SCHEDULE - H

CERTIFICATE

I / we hereby certify that the information given with this bidding document is correct. If, at any stage, it is found to be incorrect, I / we understand that the contract will be liable to be terminated and action could be taken against me/us by the Company for damages.

SIGNATURE (S) OF BIDDER WITH SEAL

(To be submitted in the letter pad of the firm indicating full name and address, telephone & fax numbers etc.)

**HLL LIFECARE LTD
(A Government of India Enterprise)
CENTRAL ENGINEERING DIVISION
P.B.NO.2, PEROORKADA P.O.,
THIRUVANANTHAPURAM - 695 005
KERALA, INDIA**

**INVITATION FOR BID (IFB)
(PRICE BID)**

FOR

**SUPPLY, INSTALLATION, INTEGRATION,
TESTING AND COMMISSIONING OF ON LINE
VULCANISING TUMBLERS IN PAIR FOR THE
BTADL CONDOM DIPPING MACHINE AT
IRAPURAM.**

IFB NO. : HLL/CED/CON-AUG/SIITC/VUL.TUMBLER/BTADL CDM/2013

DATE: 11-10-2013

**HLL LIFECARE LIMITED
CENTRAL ENGINEERING DIVISION
(A GOVT. OF INDIA ENTERPRISE)
PEROORKADA. P.O, TRIVANDRUM 695 005**

IFB NO. : HLL/CED/CON-AUG/SIITC/VUL.TUMBLER/BTADL CDM/2013

DATE: 11-10-2013

**PRICE BID – RATE SCHEDULE FOR SUPPLY INSTALLATION,
INTEGRATION, TESTING AND COMMISSIONING OF ON
LINE VULCANISING TUMBLERS IN PAIR(FOR THE
BTALDCD MACHINE AT IRAPURAM.**

NAME OF TENDERER:

Quantity : 2 SETS

PRICE PARTICULARS	PER UNIT (IN RS.)	REMARKS
BASIC PRICE FOR ON LINE TUMBLER VULCANISING SYSTEM.		
BASIC PRICE FOR CONTROL UNIT FOR PRODUCT SENSING AND SYNCHRONISATION		
EXCISE DUTY (% TO BE FURNISHED)		
CESS ON EXCISE DUTY		
CST/VAT (% TO BE FURNISHED)		
FREIGHT		
INSURANCE		
INSTALLATION CHARGES		
OTHERS, IF ANY (PLEASE SPECIFY)		
TOTAL DELIVERED RATE AT HLL STORES (Rupees.....)		

MINIMUM TIME REQUIRED TO
SUPPLY, INSTALL & COMMISS
VALIDITY: ONE YEAR

PLACE:

DATE :

} NAME AND SIGNATURE OF THE TENDERER
(WITH OFFICE SEAL)

TUMBLING MACHINE

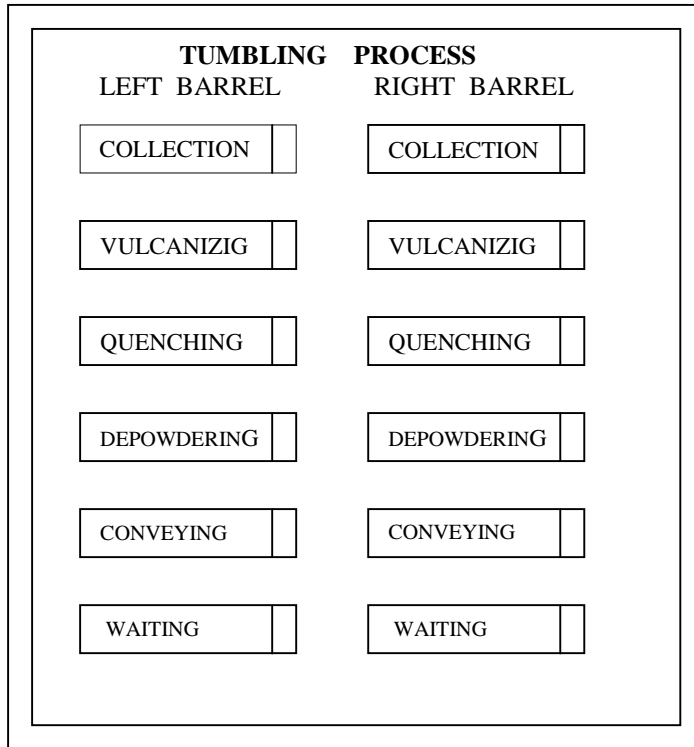

SCREEN -1(Home screen)

- Separate colour should be given for
 - Completed process - yellow
 - On going process - Green &
 - Remaining process. - Gray
- Home Screen is only for display purpose & not for actuating.
- Remaining time should also be indicated against each process.

CONTD.....

CENTRAL ENGINEERING DIVISION,
HLL LIFE CARE LIMITED

ATTACHMENT SHEET -I

CYCLE TIME SET	
COLLECTION	45
VULCANIZING	30
QUENCHING	9
DEPOWDERING	0.5
CONVEYING	4
WAITING	1.5
OVERLAPPING	1.0

SCREEN -2 (with password protection)

- These 2 screens are major. There should have a provision for varying the cycle time for each process in minutes / seconds. (key pad set)
- An overlapping time can also set in the screen.
- Process skipping & reset button should also be incorporated to skip each process whenever it is required.
- Alarm output for over temperature, over current & process error.

CENTRAL ENGINEERING DIVISION,
HLL LIFE CARE LIMITED

ATTACHMENT SHEET -I

PROCESS CONDITION

LEFT BARREL

SL. NO.	PROCESS	INPUT CONDITION	OUTPUT CONDITION
1.	COLLECTION	SUB DIVIDING- LEFT SIGNAL	LEFT BARREL- FORWARD CARRY FAN - ON
2.	VULCUNZING	-----	LEFT BARREL-FORWARD BLOWER – ON (only for the overlapping period of collection.) TEMP.CONTROLLER LEFT – ON
3.	QUENCHING	-----	BARREL LEFT-FORWARD BLOWER- ON
4.	DEPOWDERING	-----	CHUTE LEFT-ON
5.	CONVEYING	SLIDING TABLE- PRODUCT END SIGNAL	CHUTE –ON SLIDING TABLE LEFT-PRODUCT SIDE.(ON) LEFT BARREL - REVERSE
6.	WAITING	-----	ALL CONDITIONS- OFF

RIGHT BARREL

SL. NO.	PROCESS	INPUT CONDITION	OUTPUT CONDITION
1.	COLLECTION	SUB DIVIDING-RIGHT SIGNAL	RIGHT BARREL- FORWARD CARRY FAN -ON
2.	VULCUNZING	-----	RIGHT BARREL-FORWARD BLOWER –ON(only for the overlapping period of collection.) TEMP.CONTROLLER RIGHT –ON
3.	QUENCHING	-----	BARREL RIGHT-FORWARD BLOWER- ON
4.	DEPOWDERING	-----	CHUTE RIGHT-ON
5.	CONVEYING	SLIDING TABLE- PRODUCT END SIGNAL	CHUTE –ON SLIDING TABLE RIGHT-PRODUCT SIDE.(ON) RIGHT BARREL - REVERSE
6.	WAITING	-----	ALL CONDITIONS- OFF

- Vulcanizing output conditions will overlap the collection process in the last set time also. And will remain till the completion of vulcanizing process.
- All the inputs from proximity switches are 24VDC.
- All the Pneumatic solenoid valves are 230VAC.
 - Subdividing- Left - 3/2 Single sol.valve

CENTRAL ENGINEERING DIVISION,
HLL LIFE CARE LIMITED

ATTACHMENT SHEET -I

- Sub dividing – Right - 3/2 Single sol.valve
- Sliding table – left - 5/2 Single sol.valve
- Sliding table – Right - 5/2 Single sol.valve
- Chute - Left - 5/2 Single sol.valve
- Chute - Right - 5/2 Single sol.valve

Motors.

- Barrel motor - 2 nos. - 2HP, 440 VAC, 3 PHASE.
- Blower motor - 2 nos. - 2 HP,440VAC,3 PHASE
- Carry fan motor - 1no. - 7 HP, 440VAC, 3 PHASE

PANEL BOARD FOR TUMBLING MACHINE

The panel board contains the following components with proper process programming in PLC and fully wired & terminated at the bottom. The panel size should be 1800 x600x400 mm including base, powder coated and the cable entry should be back at the bottom.

The panel board consists of minimum following components.-

Fronnd panel

1. Selector switch 3 way - 9 nos.
2. Push switch - 3 nos.
3. Indicators (LED) - 19 nos.
4. Buzzer - 1.no.
5. HMI (touch screen) - 1 no.
6. Temperature controller - 2 nos.

Panel Inside.

1. Main Isolator / MCCB,3 phase,440VAC - 1 no.
2. MPCB , 2 HP,3phase ,440VAC - 4 nos.
3. MPCB, 7.5 HP,3phase ,440VAC - 1 no.
4. MCB, 5 A,230VAC - 3 nos.
5. Contactor for 2 HP motor,3 phase,440VAC - 6 nos.
6. Contactor for 7 HP motor,3 phase,440VAC - 1 no.
7. Contactor, 10 A - 2 nos.
8. Power supply,230VAc/ 24 VDC 5A - 1No.
9. Relays, 24 vdc - 20 nos.
10. Isolation Transformer 230/230Vac - 1no.
11. Panel board Exhaust Fan - 1 no.
12. Panel lamp - 1 no.
13. PLC - 1no.

CENTRAL ENGINEERING DIVISION,
HLL LIFE CARE LIMITED

ATTACHMENT SHEET -I

All the Electrical switch gears should be Schneider/ A-B/ Pepperl& Fuchs / Sprecher+ Schuh/ Siemens/L&T make and all other selector switches / components should be branded. The party may be contacted with Instrumentation dept. for the program algorithm and i/o conditions for the same.

PANEL INSIDE (approx.)

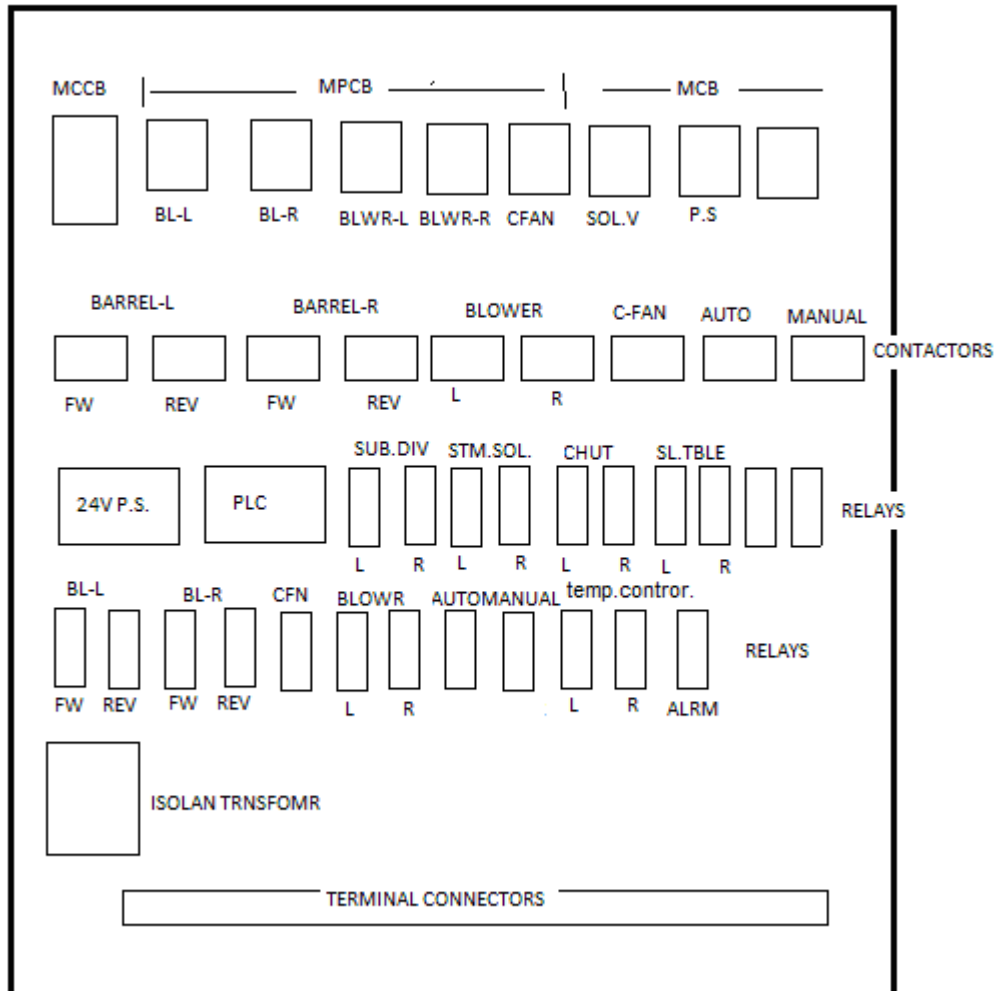

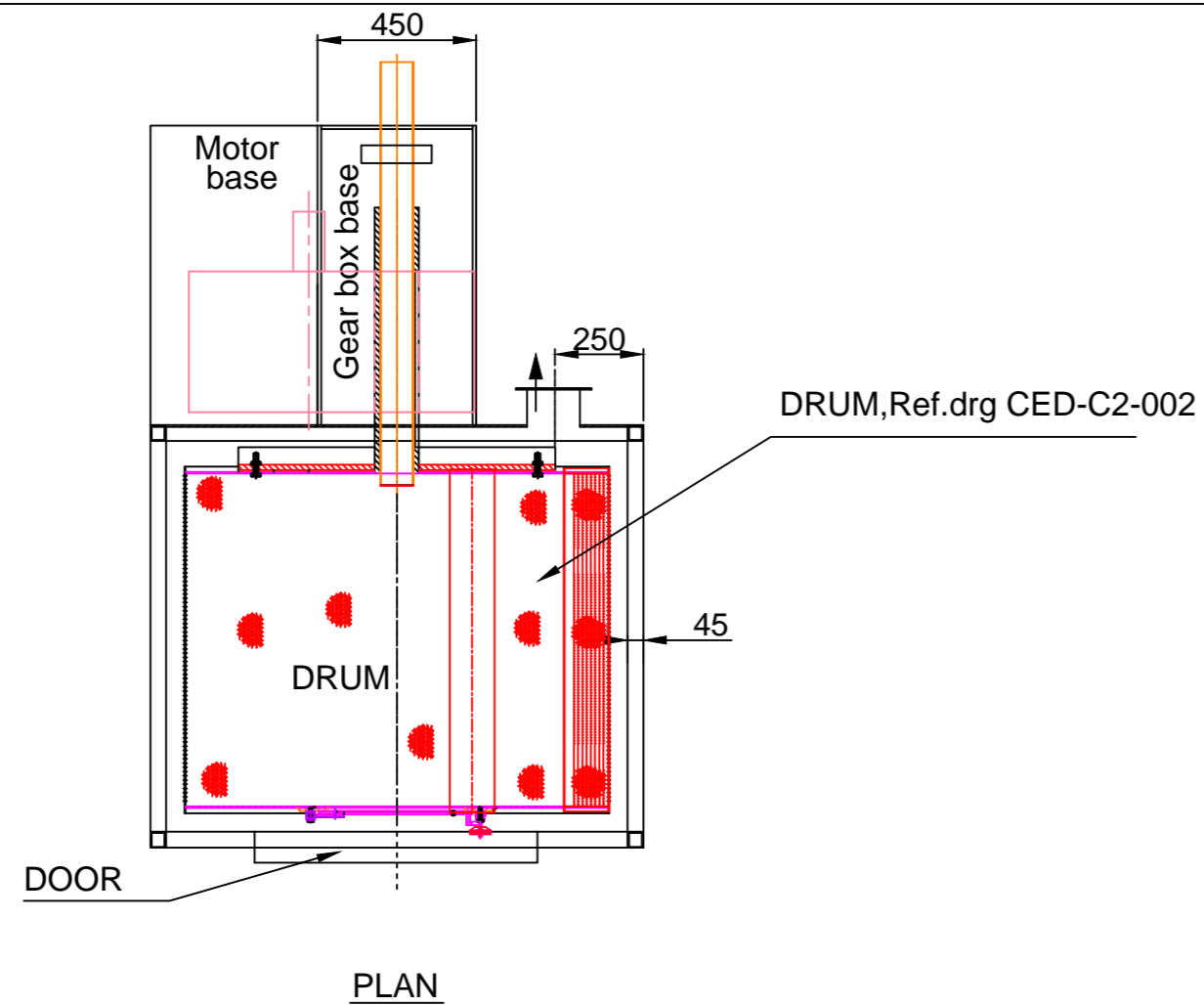

SL: No:	ITEMS	MATERIAL	QTY
1.	STRUCTURE	IS226, Powder Coated.	
2.	DRUM	AISI 316 L	2 Nos
3.	CHUTE	AISI 316L	2 Nos
4.	MOTOR & GEAR BOX		2 set.
5.	BLOWER & Motor	Flow rate 10m ³ /min. Capacity = 1.5kw, 1400 rpm	2 Nos
6.	TROLLEY	IS226, Powder Coated.	2 Nos
7.	HEAT EXCHANGER	Flow rate 10m ³ /min. Capacity = 10kw	2 Nos
8.	PANEL BOARD	As per attachment of sheet no. 1	1 No

Note: Above items Quantity using for two machines
Raw materials mill certificate should be produced

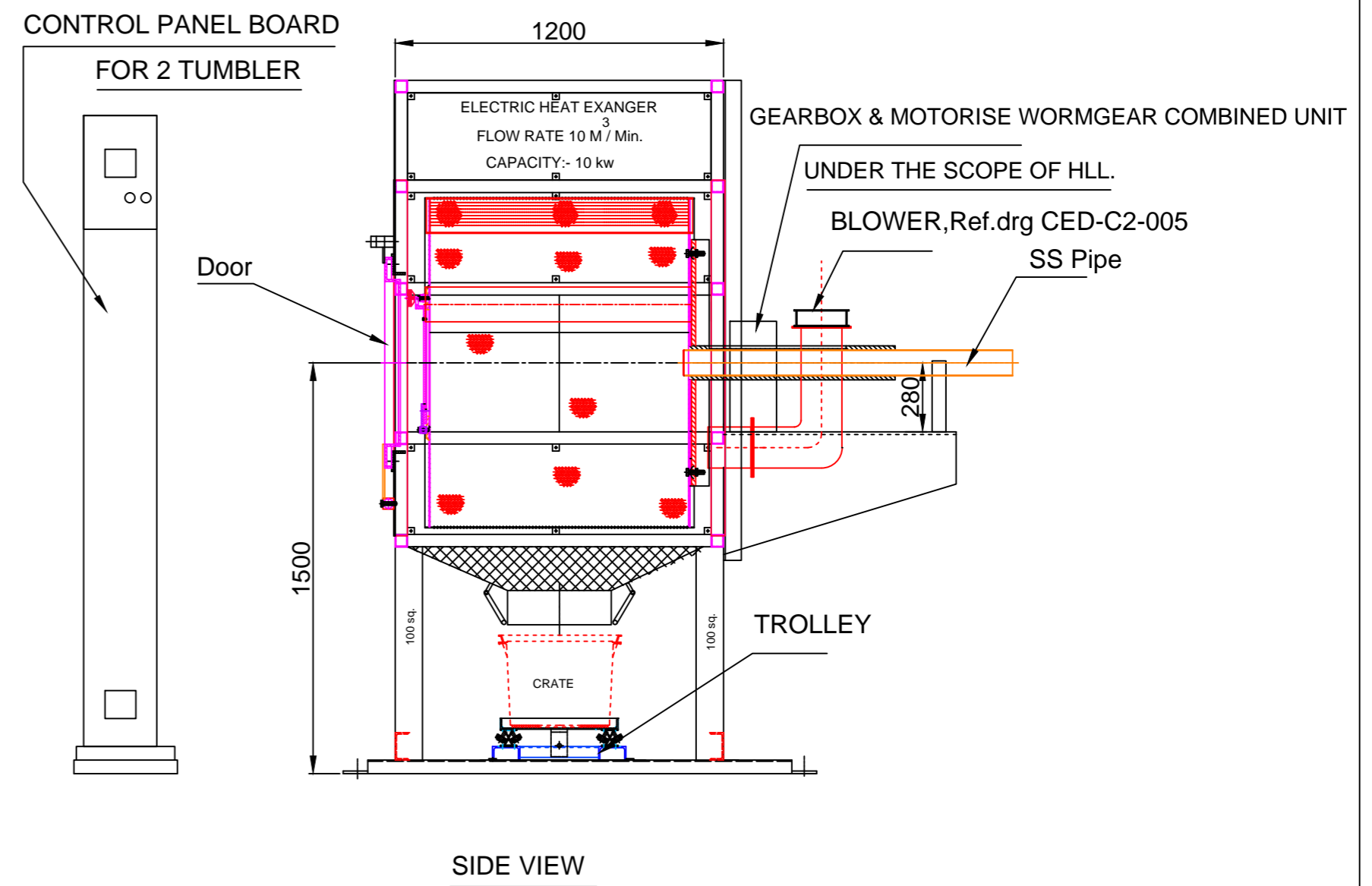
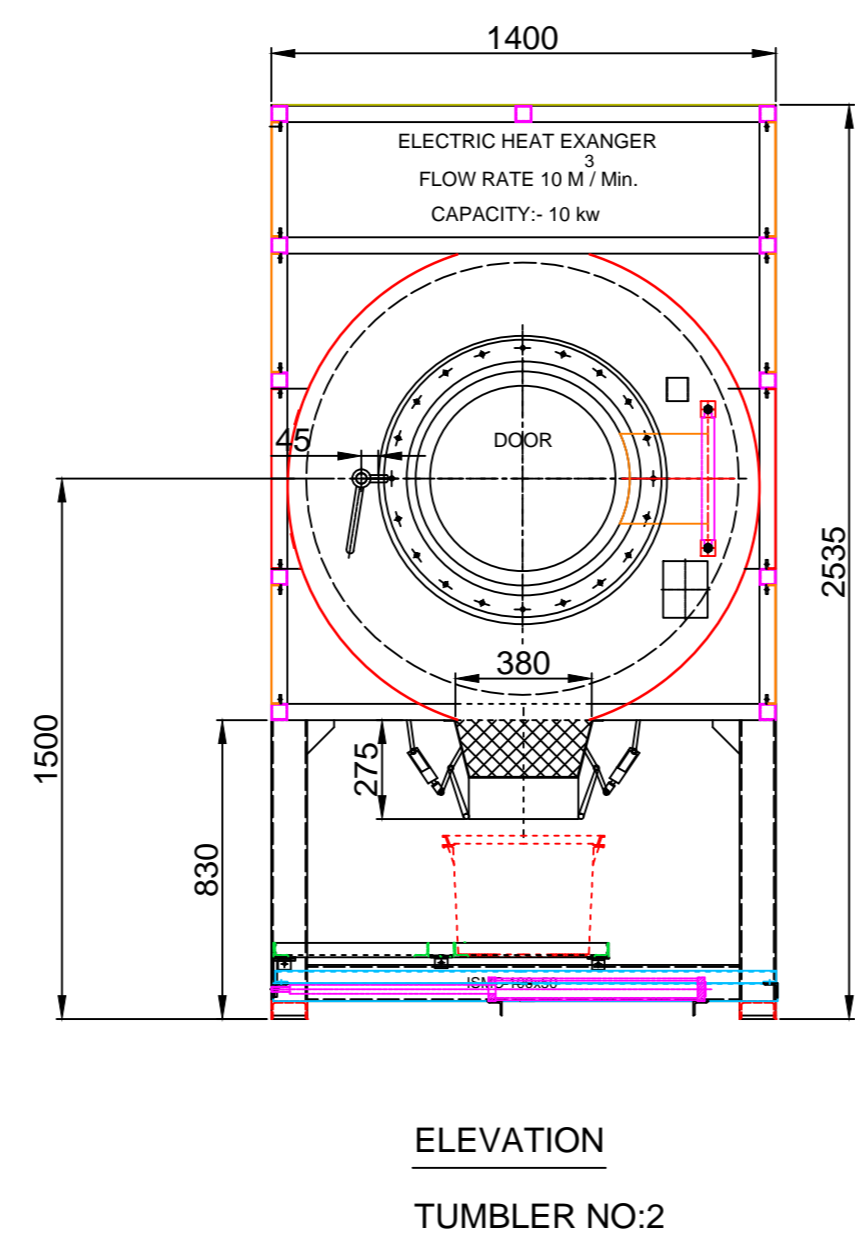
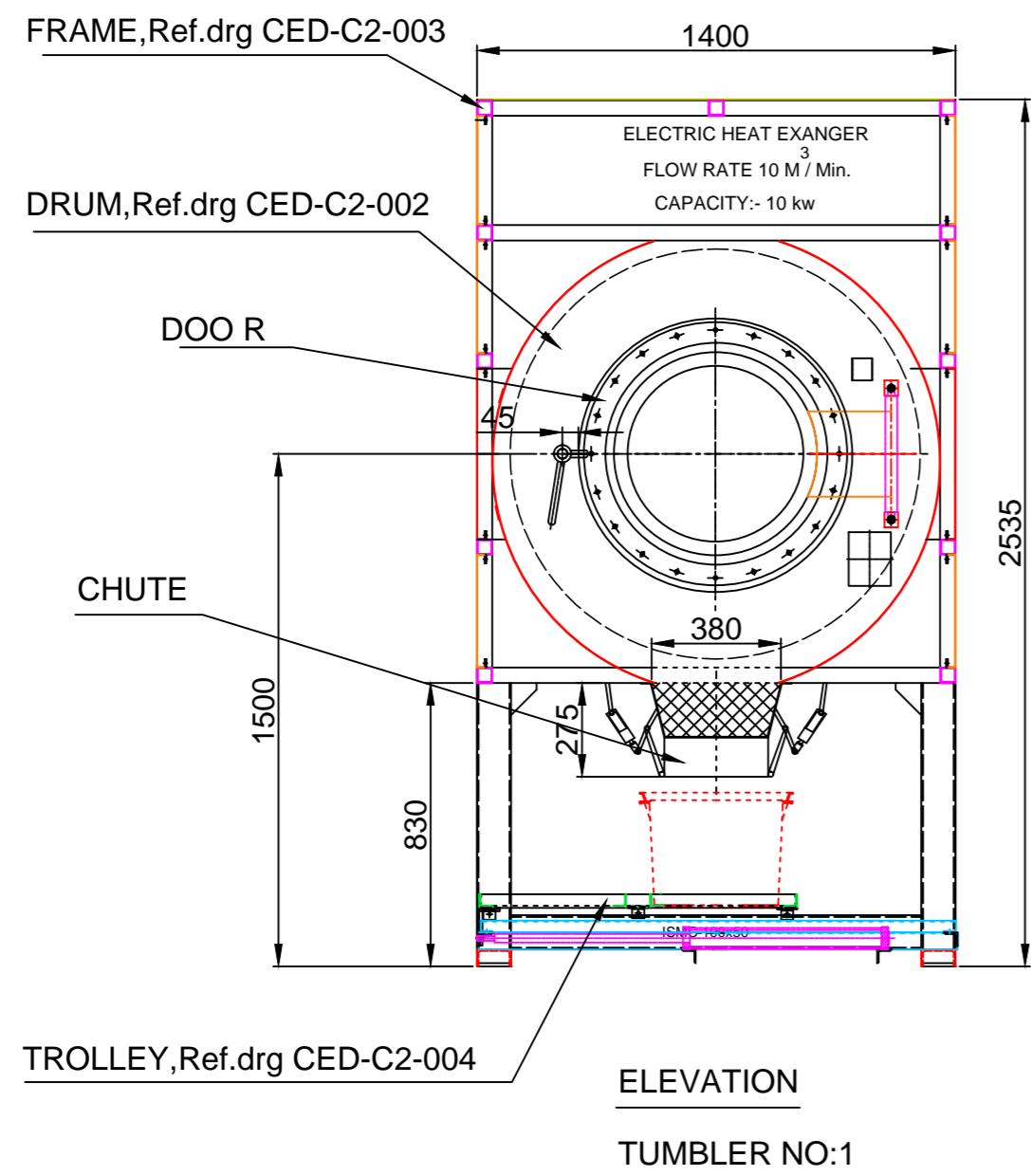

MATERIAL:	HLL LIFECARE LIMITED.		NO:OFF.
	Thiruvananthapuram-5		
DRAWN BY:	fredy joseph	TITLE:-	ASSEMBLY OF TUMBLER
CHECKED BY:			
APPROVED BY:			
DATE:	01-07 - 2013		Drg.no:-HLL-CED-C2-001-00
SCALE:			SHEET NO: 1 OF 1
ALL DIMENSIONS ARE IN M.M			

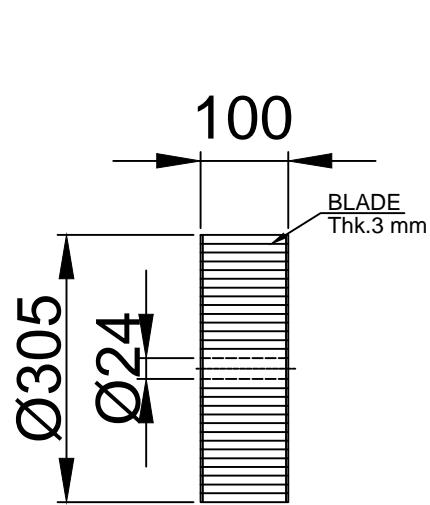

IMPELLOR

M.S MATERIALS ARE TO BE SURFACE COATED
WITH CR PLATING/GALVANIZING

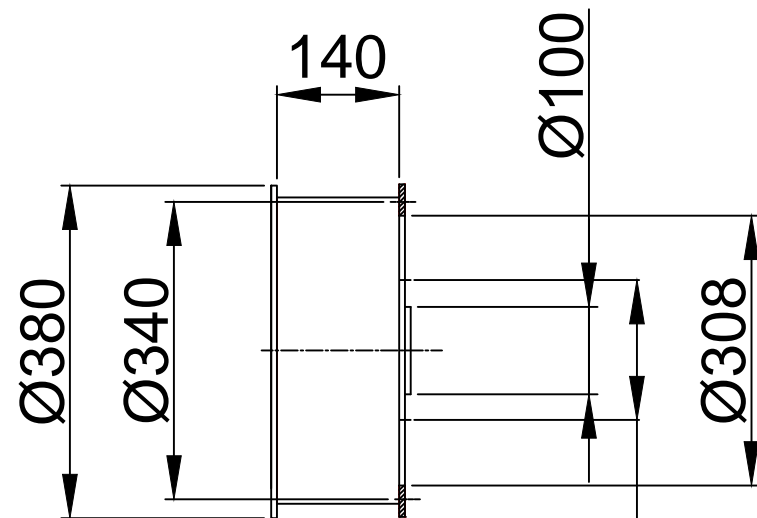

OUTERBODY (Impellor)

MATERIAL: IS226

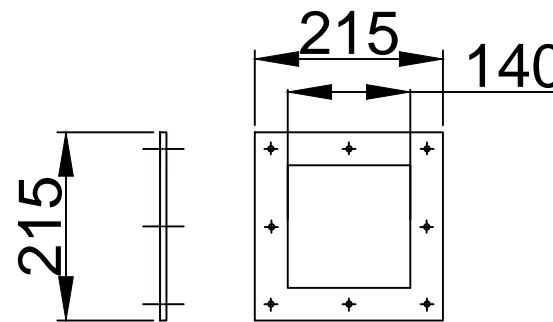

SQ.FLANGE

MATERIAL: IS226

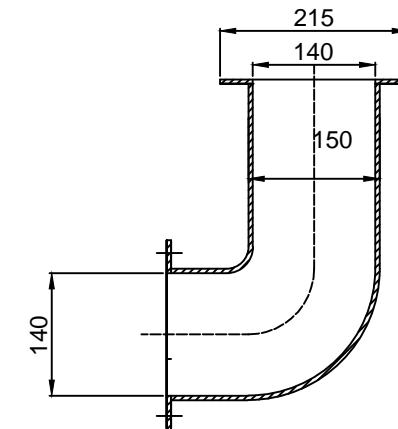

DUCT

MATERIAL: IS226

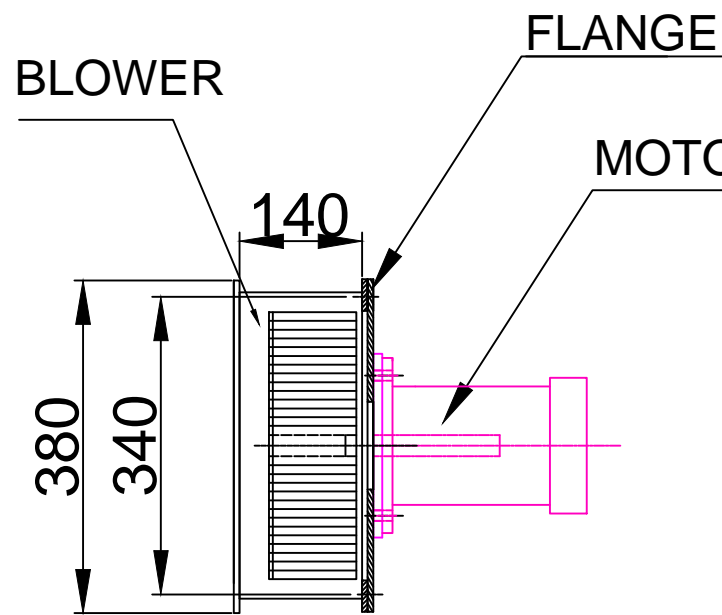

ASSEMBLY

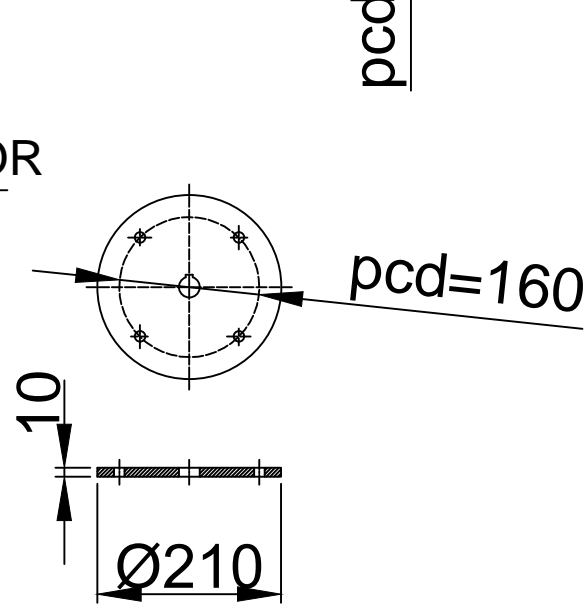

FLANGE (MOTOR BASE)

MATERIAL: IS226

Note:- 3
FLOW RATE:- 10 M / Minute
Capacity of Motor :- 1.5 kw.
R P M :- 3000

Make:- LENZE/SEW/SIMENS/SUMITOMO/ABB/CG

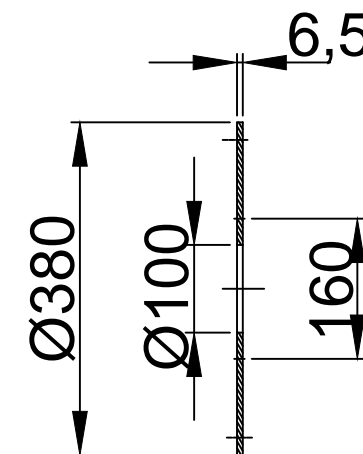

FLANGE

MATERIAL: IS226

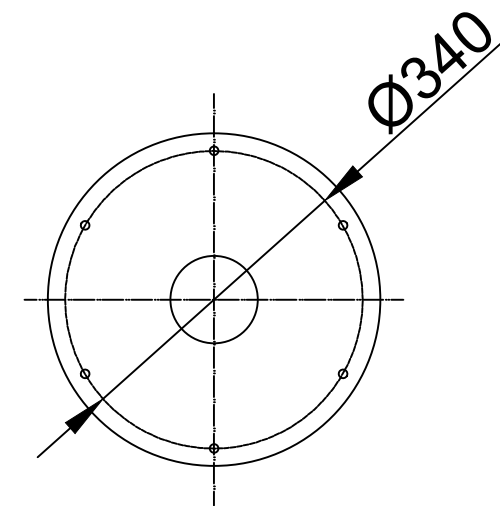

MATERIAL:	HLL LIFECARE LIMITED.		NO:OFF.
	Thiruvananthapuram-5		
DRAWN BY:	Fredy Joseph	TITLE:- BLOWER FOR TUMBLER	
CHECKED BY:			
APPROVED BY:			
DATE:	20-06 - 2013	Drg : No: HLL-CED- C2 -005-00	
SCALE:			
ALL DIMENSIONS ARE IN M.M		SHEET NO: 1 OF1 REV:- 0.	

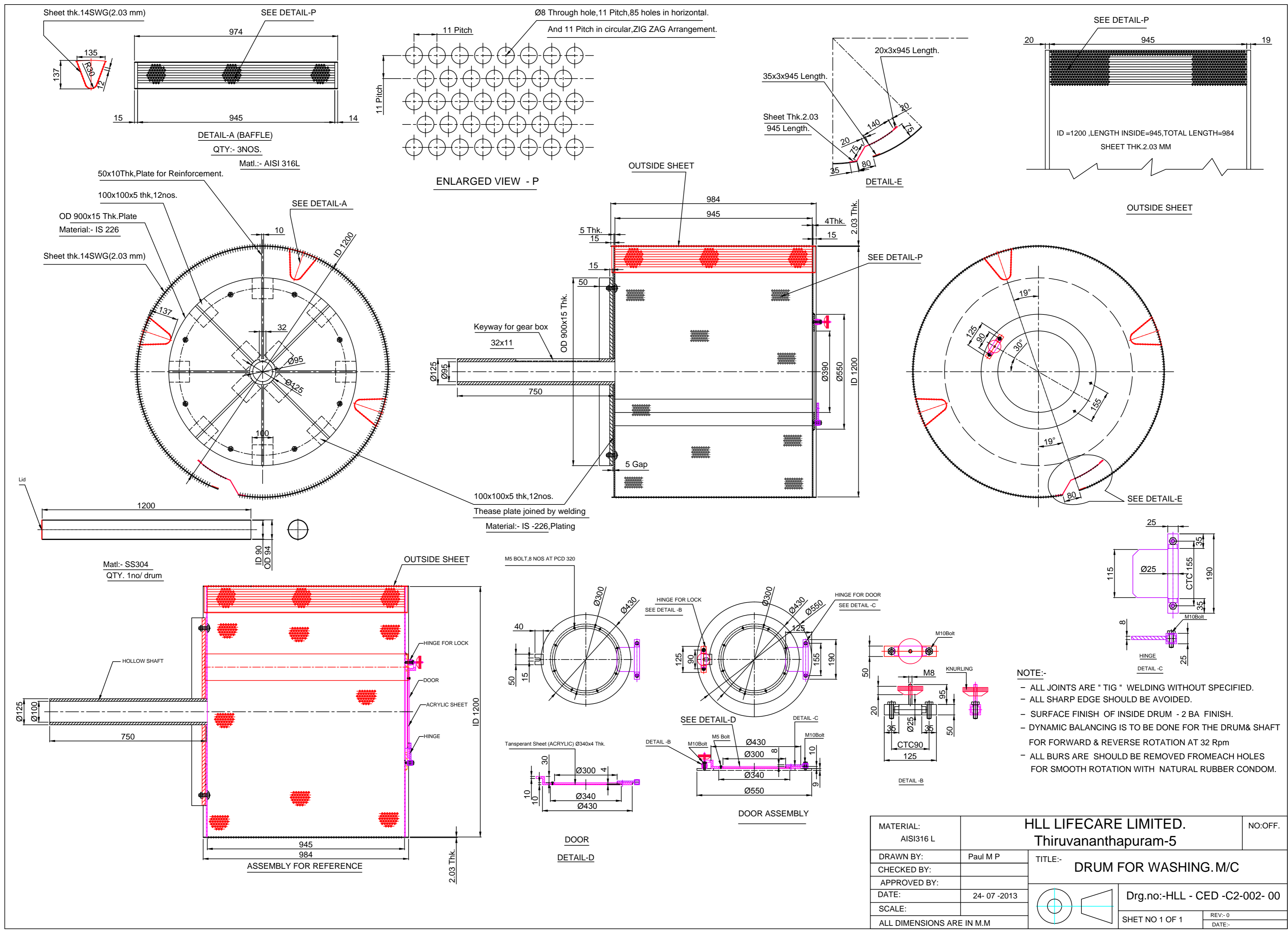

NOTE:-

- ALL JOINTS ARE " TIG " WELDING WITHOUT SPECIFIED.
- ALL SHARP EDGE SHOULD BE AVOIDED.
- SURFACE FINISH OF INSIDE DRUM - 2 BA FINISH.
- DYNAMIC BALANCING IS TO BE DONE FOR THE DRUM& SHAFT FOR FORWARD & REVERSE ROTATION AT 32 Rpm
- ALL BURS ARE SHOULD BE REMOVED FROM EACH HOLES FOR SMOOTH ROTATION WITH NATURAL RUBBER CONDOM.

MATERIAL: AISI316 L		HLL LIFECARE LIMITED. Thiruvananthapuram-5		NO:OFF.
DRAWN BY: Paul M P		TITLE:- DRUM FOR WASHING. M/C		
CHECKED BY:		DATE: 24-07-2013		
APPROVED BY:		SCALE:		
DATE:		ALL DIMENSIONS ARE IN M.M		
SCALE:		SHEET NO 1 OF 1		REV:-0 DATE:-

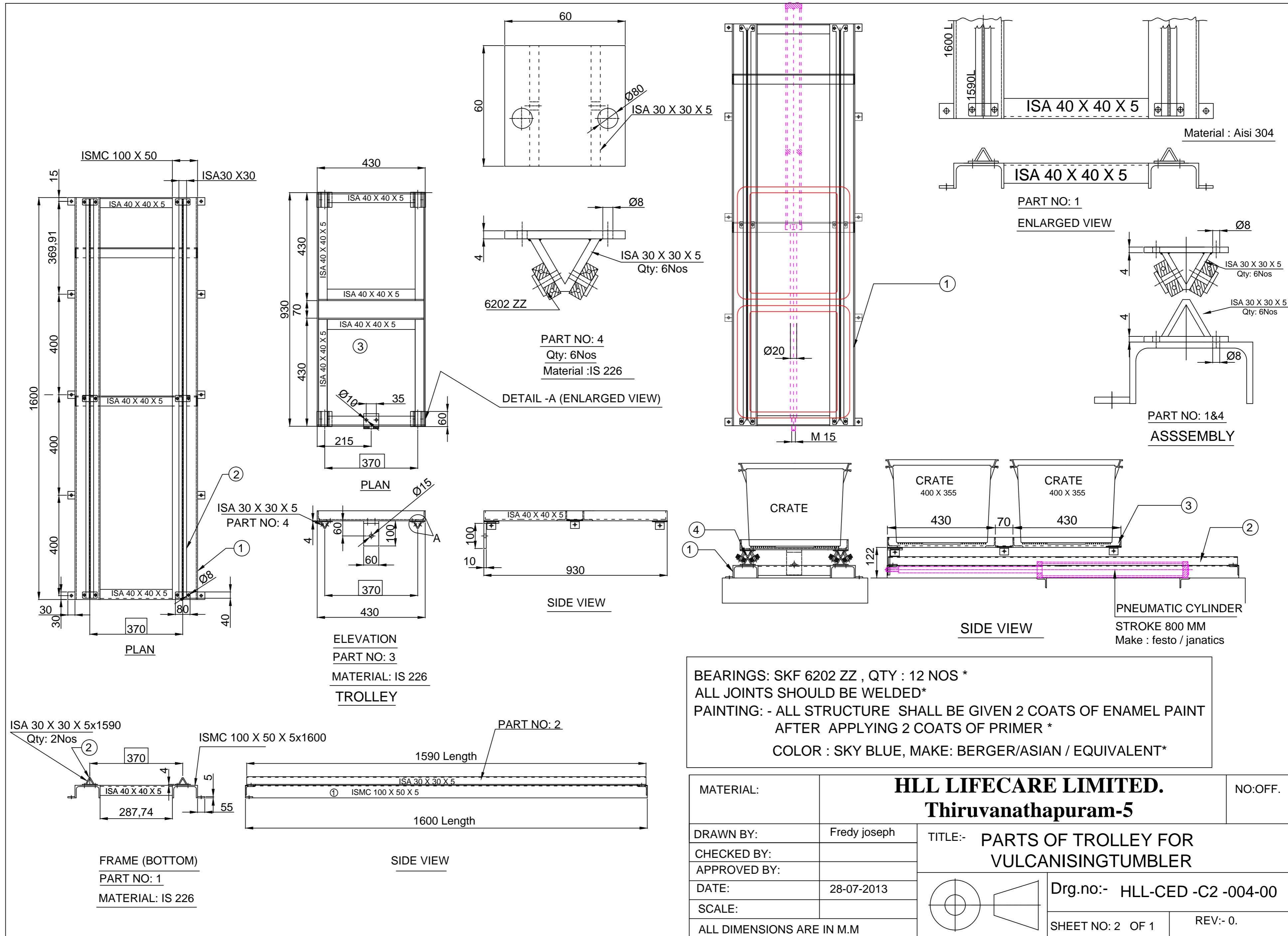

BEARINGS: SKF 6202 ZZ , QTY : 12 NOS *
 ALL JOINTS SHOULD BE WELDED*
 PAINTING: - ALL STRUCTURE SHALL BE GIVEN 2 COATS OF ENAMEL PAINT
 AFTER APPLYING 2 COATS OF PRIMER *
 COLOR : SKY BLUE, MAKE: BERGER/ASIAN / EQUIVALENT*

MATERIAL:		HLL LIFECARE LIMITED. Thiruvananthapuram-5		NO.OFF.
DRAWN BY:		Fredy joseph	TITLE:- PARTS OF TROLLEY FOR VULCANISING TUMBLER	
CHECKED BY:				
APPROVED BY:			Drg.no:- HLL-CED -C2 -004-00	
DATE:		28-07-2013		
SCALE:			SHEET NO: 2 OF 1 REV:- 0.	
ALL DIMENSIONS ARE IN M.M				

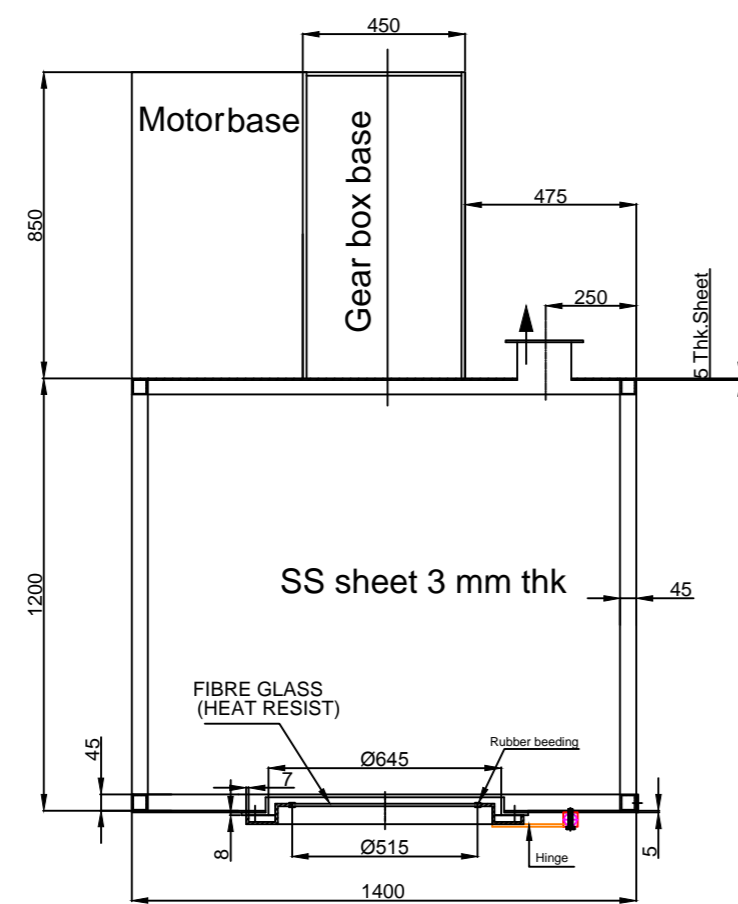

PLAN

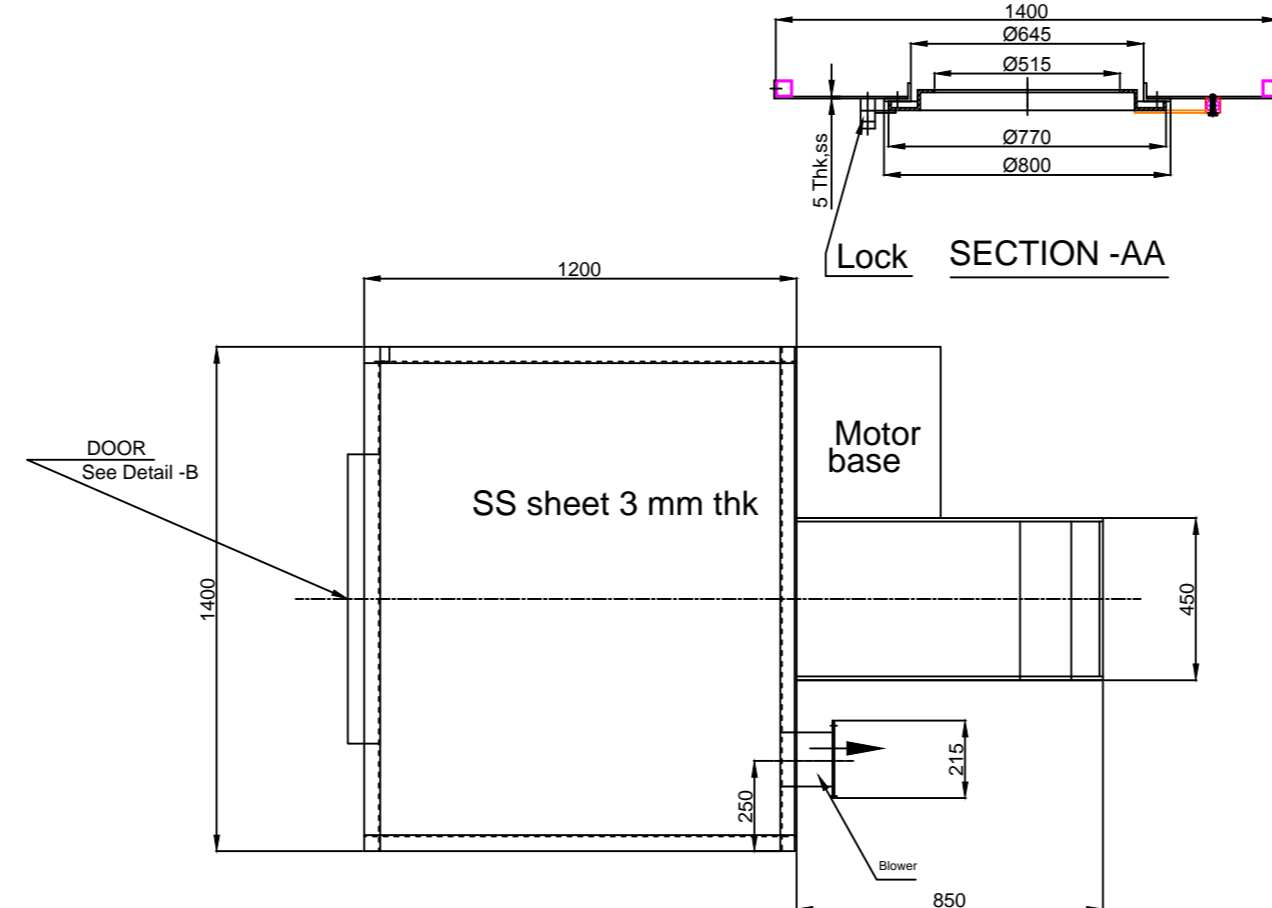

PLAN (SIDE VIEW)

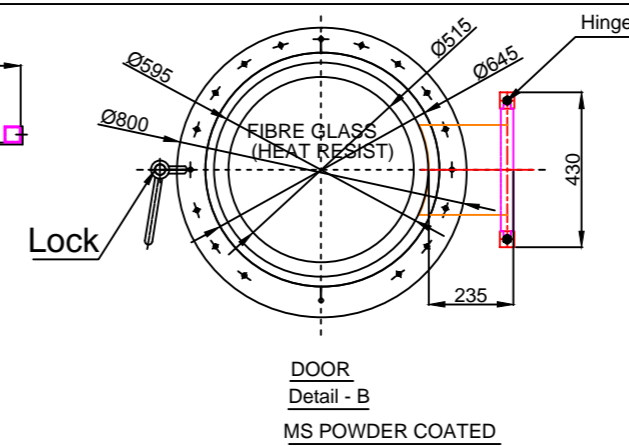

SECTION-AA

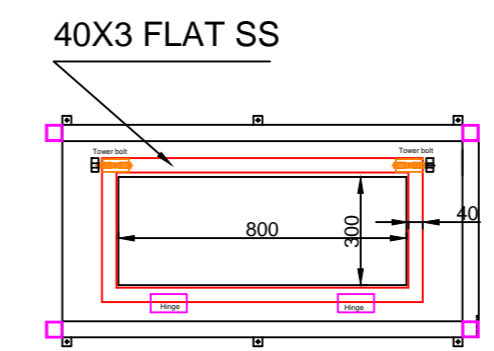

VIEW FROM -P

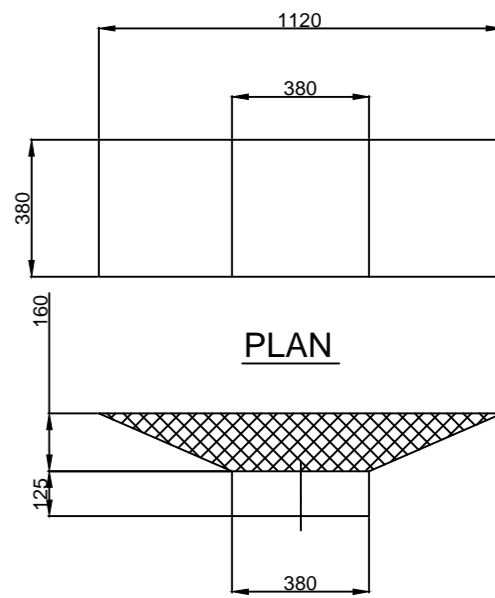

PLAN

CHUTE
VIEW FROM - BB
MATERIAL : SS 316L

PNEUMATIC CYLINDER
Make:- JANATICS, Model no:- A 120320500

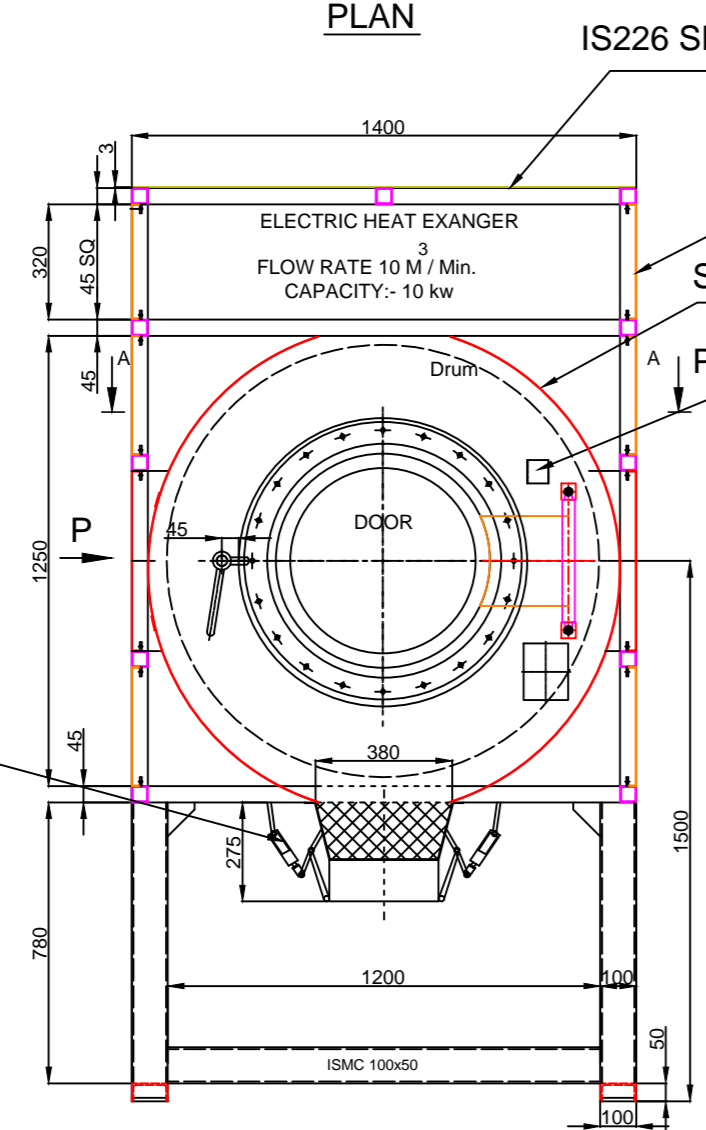

ELEVATION

MATERIAL: IS 226, Powder Coated
SIZE : 1400 B X 2200 H

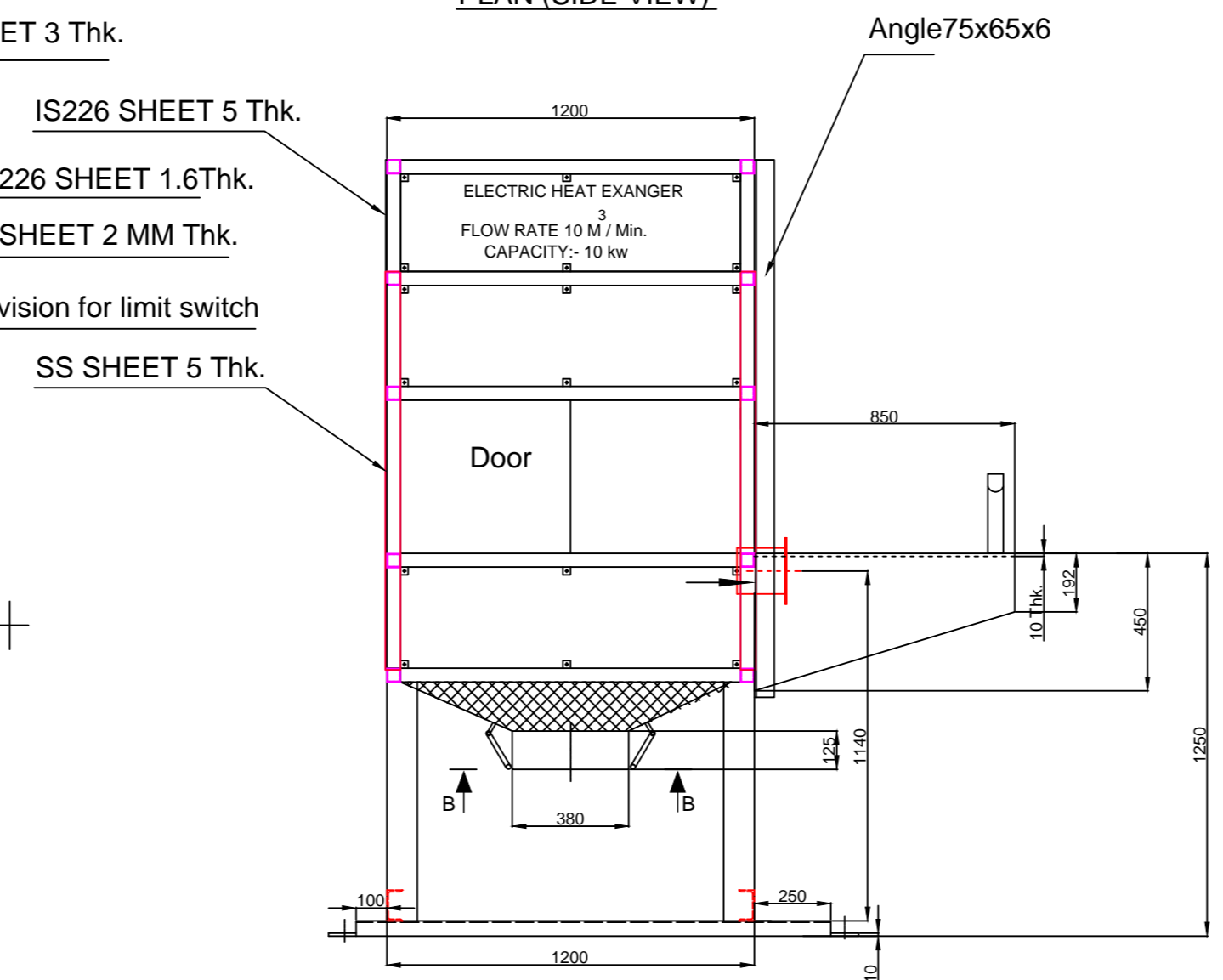

SIDE VIEW

SIZE : 1200 B X 2200 H

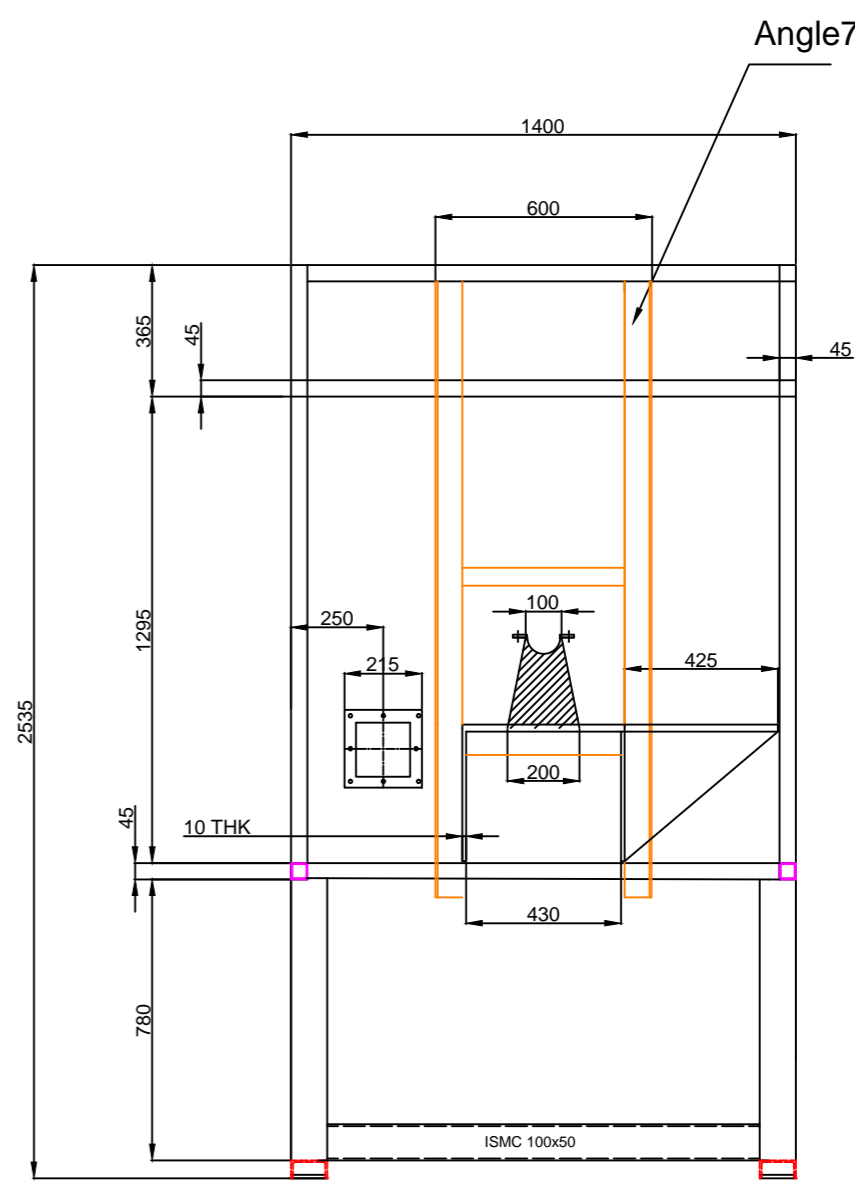

BACK SIDE VIEW (TUMBLER)

MATERIAL:	HLL LIFECARE LIMITED.		NO:OFF.
	Thiruvananthapuram-5		
DRAWN BY:	TITLE:- STRUCTURE FOR TUMBLER		
CHECKED BY:			
APPROVED BY:			
DATE:	01-07 - 2013	Drg.no:-HLL-CED-C2-003-00	
SCALE:		SHEET NO: 1 OF 1	
ALL DIMENSIONS ARE IN M.M		REV:- 0.	