

**HLL LIFECARE LTD,  
CENTRAL ENGINEERING DIVISION  
PEROORKADA FACTORY,  
THIRUVANANTHAPURAM – 695 005,  
KERALA, INDIA.  
PHN: ++91 471 2437270  
FAX: ++91 471 2432647**

# **TENDER DOCUMENT**

**SUPPLY, INSTALLATION, INTEGRATION,  
TESTING AND COMMISSIONING OF ON LINE  
POWDER FINISHING SYSTEM FOR THE BTADL  
CONDOM DIPPING MACHINE  
AT  
HLL KANAGALA FACTORY**

**IFB No.: HLL/CED/CON-AUG /SITC/ONLINE PFS/BTADL CDM/KFB/2014  
DATE: 05.06.2014**

**HLL LIFECARE LIMITED**  
(A Government of India Enterprise)  
Central Engineering Division, Peroorkada. P.O,  
Thiruvananthapuram – 695005,  
Kerala, India  
Phn: 0471- 2433374,2437270, 2435090  
Fax No. (0471) 2432647

**INVITATION FOR BIDS (IFB)**

IFB No.: HLL/CED/CON-AUG /SITC/ONLINE PFS/BTADL CDM/KFB/2014  
DATE: 05.06.2014

HLL Lifecare Limited (HLL) invites sealed and super scribed bids from competent and experienced eligible Suppliers/Contractors for the supply of following item in connection with the Augmentation of condom production at our factory in Kanagala, Karnataka.

Sl. No	Brief Description of Item/Work	Quantity	EMD
1	Supply, Installation, Integration, Testing and Commissioning of On Line powder finishing operation system for the BTADL Condom Dipping Machine on turnkey basis as per drawing and specifications at our HLL, Kanagala Factory, Karnataka	As per schedule of items	Rs 20,000

**SCHEDULE I**

**INSTRUCTION TO BIDDERS:**

1. A complete set of bid documents can be had from the Office of the Associate Vice President (CED), Central Engineering Division, HLL Lifecare Limited, Peroorkada Factory, Thiruvananthapuram – 695 005, Kerala, India during office hours on any working day on submission of written application.

The Tender Documents can also be downloaded from our Website [www.lifecarehll.com](http://www.lifecarehll.com) and the Central Public Procurement Portal of Government of India [www.eprocure.gov.in](http://www.eprocure.gov.in) from the date of issue of tender document. Tender forms shall be filled in ink or typed. No tender filled in pencil shall be considered. The tenderer shall sign and seal the form at each page and at the end, in token of acceptance of all the terms and conditions of the tender. Any subsequent changes/amendments will be published only in our website & CPP portal.

2. The scheduled date for issue, receipt and opening of bids is as follows.

- a) Date of issue of tender document - 05.06.2014
- b) Last date and time for receipt of bids - 12.06.2014 up to 15.00 Hrs.
- c) Date and time of opening of bids - 12.06.2014, 15.30 Hrs.
- d) Address for communication, receipt and place of opening of bids:

Associate Vice President (CED)  
Central Engineering Division,  
HLL Lifecare Limited (A Government of India Enterprise),  
PB No 2, Peroorkada, Thiruvananthapuram – 695005,  
Kerala State, India  
Ph: (++91 471) 2433374,2437270 –501,502  
Tele Fax: (++ 91 471) 2432647  
E-mail: srnair@lifecarehll.com, [rajeevrv@lifecarehll.com](mailto:rajeevrv@lifecarehll.com)

3. All the bidders are requested to attend the pre-bid meeting is scheduled on 10.06.2014.,2.30PM at AVP(CED)'s office

4. The Bid must include the following information;

- a. Enquiry No.
- b. EMD
- c. Promised Delivery Schedule for each item.
- d. Acceptance Form (Schedule III)
- e. Price Schedule in Format For Quoting (Schedule IV)
- f. All other documents/certificate/information as specified in the bid document.

5. Each bid must be accompanied by E.M.D. The EMD shall be in the form of Demand Draft from a nationalized bank drawn in favour of HLL LIFECARE LTD, Thiruvananthapuram payable at Thiruvananthapuram. E.M.D. of the unsuccessful bidders will be released after evaluating tenders, keeping only the earnest money of the first three lowest bidders. The earnest money deposit of the remaining two unsuccessful bidders will be released after the acceptance of the notification of award by the successful bidder. The EMD may be forfeited, if a Bidder withdraws his bid during the period of bid validity specified by the Bidder on the Bid Document.

6. SSI units interested in availing exemption from payment of EMD should submit a valid copy of their registration certificate issued by the concerned DIC or NSIC.

7. In addition to the invitation for bids, the bidding documents include the following schedules.

- Schedule I - Instruction to the Bidders
- Schedule II - Conditions of Contract
- Schedule III - Specifications
- Schedule IV - Acceptance Form
- Schedule V - Format for quoting

8. The completed and sealed bid documents should be submitted to Associate Vice President (CED), in the above address. The outer cover should bear the Enquiry No, closing date and General description of item tendered, and the words "DO NOT OPEN BEFORE" 15.30 Hrs (IST) on ----- (Indicate the Closing Date).

9. Bids will be opened in the presence of bidders' representative(s) who choose to attend on the specified date and time, at the office of HLL at the address given in Clause 2 (d) above.

10. In the event of the date specified for bid receipt and opening being declared as a closed holiday for purchaser's office, the due date for submission of bids and opening of bids will be the following working day at the appointed times.

11. The purchaser may, at its discretion, extend this deadline for submission of bids by amending the Bid Documents or any other reasons, in which case all rights and obligations of the Purchaser and Bidders previously subject to the deadline will thereafter be subject to the deadline as extended.

12. Purchaser will not be held responsible for the postal delay, if any, in the delivery of the bidding document or the non-receipt of the same. Bids sent by Telex/Fax/Telegraph will not be accepted.

13 HLL reserves the right to club or split the items of works, change the qualifying criteria at their discretion and to reject or cancel the Invitation for bids without assigning any reason thereof.

**ASSOCIATE VICE PRESIDENT (CED)**

## **SCHEDULE II**

### **CONDITIONS OF CONTRACT**

#### **1) PRICE**

The price quoted should be inclusive of Basic Price, all applicable taxes and duties including VAT, Entry tax, Octroi & other levies, P&F charges, loading and unloading charges, insurance, etc. The Supplier should pay entry taxes, as applicable and should be included in the offer.

The Format for Quoting (Schedule IV) shall be suitably filled as applicable. The quoted rate shall be valid for a period of 31<sup>st</sup> Aug 2014. No price escalation and no change in terms and conditions will be allowed on any ground till the order is completely executed.

#### **2) TAXES/DUTIES/LEVIES**

The supplier shall be entirely responsible for all taxes including entry tax, duties, license fees, etc. incurred until successful completion of contract. All central, state, municipal taxes, duties and levies payable shall be shown by the bidder separately in the Bid. The Purchaser will issue necessary 'C' Form, if required.

#### **3) COMPLETION TIME**

- a. The item should be delivered within 18 days from the date of issuing the Letter of Intent or Supply Order.
- b. The quantity mentioned herein are approximate requirement with staggered delivery.
- c. In case less or more quantity is required the suppliers should be prepared to effect supply at short notice on the same terms and conditions.

#### **4) GUARANTEE PERIOD**

The Guarantee against any possible manufacturing defects shall be given for a period of 18 months from the date of supply and inspection of the item at HLL site or 12 months from the date of supply, whichever is earlier.

## **5) DELIVERY ADDRESS**

### **For online powder finishing system - 1 set**

- 5.1 Senior Manager (CP)  
HLL Lifecare Limited (A Government of India Enterprise),  
Kanagala, Dist , Belgaum – 591225,  
Karnataka State, India  
Ph: (++91 833) 279244,279207  
Tele Fax: (++ 91 833) 279245

## **6) LIQUIDATED DAMAGES FOR DELAYS**

If the material is not supplied to the purchaser within the time stipulated in the Order, Purchaser may at their option, either (1) recover from the Supplier liquidated damages at the rate of 0.5 % of the total purchase order value for every week of delay, subject to a maximum of 7.5 % of the total purchase order value, or (2) at the risk and cost of the Supplier and without prejudice to the other remedies/rights as per the Contract, terminate the order wholly or partially and complete it themselves or reassign it to other Suppliers.

## **7) PAYMENT TERMS**

60% of the total supply price will be paid against supply, inspection and acceptance of the items at HLL, Kanagala site, within 30 days and 30 % after successful installation within six days , balance 10% will be released against performance bank guarantee valid for guarantee period as per tender.

## **7. SETTLEMENT OF DISPUTES**

Any disputes or differences or questions or claims arising under or relating to or touching this agreement shall be referred for arbitration to a Sole Arbitrator under the provisions of the Arbitration and Conciliation Act 1996 or any statutory modification or re-enactment thereof for the time be in force. The award passed by the arbitrator shall be final and binding on the parties hereto.

The contract shall be deemed to have been concluded at Thiruvananthapuram, Kerala and suits and proceedings, if any, shall be only in the courts of competent jurisdiction in Thiruvananthapuram.

The venue of arbitration shall be the place from where the contract is issued.

**The company reserves the right to club or split the items of supply and reject or cancel the Invitation for bids without assigning any reason thereof.**

## SCHEDULE III

### **SPECIFICATIONS**

#### **Part - A**

#### **Requirement**

HLL require On Line powder finishing operation system of quantity 2 nos (1 Set each) for two Butterfly Type Automatic Double Line Condom Dipping Machine at our factory in Kanagala, Karnataka.

#### **Specifications**

Item: As per drawing no.

1. Drg .no:- HLL -CED - C2 -010-00 (Internal screw drum conveyor)
2. Drg .no:- HLL -CED - C2 -010-01 (Frame for screw conveyor)
3. Drg.no:-HLL - CED - C2-010-02 (Screw conveyor)
- 4 Drg .no:- HLL-CED-C2-011-00 (De-hydrator parts)
5. Drg.no:- HLL-CED-C2-011-00 (Dehydrator assembly)
6. Drg.no:- HLL-CED-C2-011-00 (Dehydrator parts list)
7. Drg.no:- HLL-CED-C2-011-01 (Circulation Tank)

#### **Powder finishing product:**

Natural Rubber Latex Male Contraceptive Condoms as per ISO 4074.

#### **DETAILS**

1. SUPPLY OF AUTOMATIC ON LINE POWDER FINISHING OPERATION AND ACCESSORIES AS PER GA DRAWING CAPABLE OF RECEIVING OF PARTIALLY DRY CONDOMS AT THE RATE OF 170 TO 240 PCS PER MIN CONTINUOUSLY.
2. THE ELECTRICAL SYSTEM SHOULD CATER THE ONLINE POWDER FINISHING OPERATION TO COMPLETE THE WASHING AND HYDRO EXTRACTION OF CONDOMS RECEIVED FROM THE BUTTERFLY TYPE AUTOMATIC DOUBLE LINE CONDOM DIPPING MACHINE WET TUMBLER.

3. THE WORKS INVOLVED ARE INCLUSIVE OF SUITABLE DESIGN, INTEGRATION, AND SYNCHRONISATION OF THE SYSTEM TO FULFIL ONLINE POWDER FINISHING OF CONDOMS RECEIVED FROM CONDOM DIPPING MACHINE WET TUMBLER. ALL ELECTRICAL AND ELECTRONIC COMPONENTS SHOULD AS PER INDIAN STANDARD.
4. **INPUT SYSTEM:** THE INPUT FROM THE WET TUMBLER TO THE SCREW CONVEYOR WILL BE THROUGH A FUNNEL (UNDER PART'S SCOPE) OF SUITABLE SIZE BY GRAVITY FORCE AND THROUGH THE CIRCULATION OF POWDER FINISHING SOLUTION TO THE FUNNEL. THE CONDOMS THEN PASS THROUGH THE INTERNAL SCREW DRUM CONVEYOR TO COMPLETE THE POWDER FINISHING PROCESS.
5. **DRIVE SYSTEM:** THE DRIVE SYSTEM USED FOR ROTATING THE INTERNAL SCREW DRUM AT **10 RPM** SHOULD BE WITH SUITABLE MOTORISED DRIVE( GEARED MOTOR IS UNDER HLL SCOPE.THE MOTORISED GEAR HAVING HOLLOW SHAFT IS CONNECTED THROUGH A SHAFT AS PER THE DRAWING GIVEN. THIS SHAFT WILL DRIVE THE PINION AND DRIVEN GEAR WITH SUITABLE RATIO SO AS TO ESTABLISH THE REQUIRED RPM. DRUM ROTATION DIRECTION SHOULD BE IN SUCH A WAY THAT THE CONDOM WITH THE SOLUTION SHOULD MOVE FORWARD POSITIVELY AT THE DESIGNATED SPEED.EW/NORD/ROSSI/SUMITOMO/BONFIGLIOLI) HAVING APPROX.
6. **HYDRO EXTRACTION:** AFTER POWDER FINISHING THE WET CONDOMS WILL PASS THROUGH A DEHYDRATOR HAVING DIRECT DRIVEN MOTORISED GEARBOX (SCOPE OF HLL) HOLLOW SHAFT ABLE TO ROTATING DE HYDRATOR AT A SPECIFIED SPEED. THIS WILL CATER THE EXACT NEEDS OF THE HYDROEXTRACTION AND PARTIAL DRYING PROCESSES. THE ROTATING DRUM AS PER DRAWING(...) IS TO BE STATICALLY BALANCED AT THE SPECIFIED SPEED OF 25 RPM
7. **HOT AIR FLOW:** A PRE- HEATER OF ELECTRICALLY OPERATED PROVIDED ON THE TOP OF THE DEHYDRATOR TO DRY THE CONDOMS FOR TRANPORTATION TO TUMBLER. THIS IS TO FACILITATE THE PRE-VULCANISING OF CONDOMS. (SUPPLY OF PRE-HEATER IS UNDER HLL SCOPE).



8. **PREHEATING CHAMBER AND CHUTE:** PARTIALLY WET CONDOMS THEN PASS THROUGH THE PRE HEATED AIR BLOWING AREA. PREHEATING CHAMBER IS TO BE MADE IN SUCH A WAY THAT THE HOT AIR FROM THE PREHEATER SHOULD BE DIRECTED TOWARDS ROTATING DEHDYDRATOR, PROPER DRYING OF CONDOMS AND AS PER DRAWING. A COLLECTION CHUTE IS ALSO TO BE PROVIDED AFTER THE PREHEATING AREA SO THAT THE CONDOMS FROM THE DEHYDRATOR CAN BE COLLECTED AT THE EJECTOR(SCOPE OF HLL).
9. **COLLECTION TANK:** A COLLECTION TANK OF MATERIAL SS316 SHALL BE PROVIDED AS PER THE DRAWING. THE TANK IS USED FOR THE COLLECTION OF LIQUID CONTAINING MgCO<sub>3</sub> & SILICON EMULSION CIRCULATED.
10. **COLLECTION FUNNEL:** A FUNNEL MADE OF SS 316L SHEET AS PER DRAWING IS TO BE PROVIDED BELOW THE WET TUMBLER TO COLLECT THE HALF WET CONDOMS AND DIRECT IT TO THE POWDER FINISHING DRUM ALONG WITH CIRCULATED WATER WITH MgCO<sub>3</sub> & SILICON EMULSION. THIS WOULD HELP THE CONDOMS TO MOVE FORWARD TO THE POWDER FINISHING SCREW WITHOUT ANY BLOCKAGE.
11. **CIRCULATING PIPE:** A PIPE OF SIZE 1" (PVS PRESSURE CLASS 10 KG/SQ.CM) TO BE USED FOR THE CIRCULATION OF THE SOLUTION. PIPES ARE TO BE PROVIDED WITH HOLES FOR THE FREE FLOW CONDOMS THROUGH THE FUNNEL AND INSIDE THE TANK FOR STIRRING.
12. **SAFETY REQUIREMNT:** NOISE LEVEL SHOULD BE 75 DB WHILE IN OPERATION.
13. **ENGINEERING REQUIREMENT:**
  - DESIGN OF EQUIPMENT SHOULD ENHANCE CLEANING FEASIBILITY BY PROVIDING NO SHARP CORNERS, MINIMUM CREVICES & SMOOTH FINISHED WELD JOINTS.
  - THE MATERIAL USED FOR THE INTERNAL SCREW DRUM CONVEYOR SHOULD BE CONSTRUCTED OF 316L GRADE STAINLESS STEEL WITH INTERNAL MIRROR SURFACE FINISH < 0.5µM Ra. CONDOMS SHOULD NOT BE DAMAGED WHILE PASSING THROUGH THE DRUM.

- THE MATERIAL USED FOR THE DE HYDRATOR DRUM AND MESH SHOULD BE CONSTRUCTED OF 316L GRADE STAINLESS STEEL WITH BUFFED QUALITY SURFACE FINISH < 0.5µM Ra CONDOMS SHOULD NOT BE DAMAGED WHILE PASSING THROUGH THE DEDYDRATOR.
- GASKETS, SEALS & O –RINGS COMING IN DIRECT/INDIRECT CONTACT SURFACES SHOULD BE CONSTRUCTED OF WHO APPROVED FOOD GRADE MATERIALS ONLY.
- ALL MATERIAL SHOULD HAVE TEST CERTIFICATE.
- EQUIPMENT SHOULD BE FABRICATED BY FOLLOWING ALL GOOD ENGINEERING PRACTICES.
- SYSTEM SHALL BE INSPECTED & TESTED AT VENDORS SITE.

14. THE MATERIAL USED IN THE PATHS AND CONTACT PARTS SHOULD BE PERFECTLY IN CONFORMANCE TO ELIMINATE HANDLING DAMAGE TO THE NATURAL RUBBER PRODUCT AND AS PER WHO GMP STANDARDS.

15. ALL CONTROLLERS SHOULD BE SUITABLE FOR WITHSTANDING POWER FLUCTUATIONS AND WITH SOFT STARTING TECHNOLOGY. SUITABLE PANEL BOARD SHOULD BE PROVIDED AT REMOTE AREA COMPLYING ALL SAFETY NORMS.

16. NECESSARY PAINTING WORKS SUITABLE FOR DUSTY AND HOT ENVIRONMENT AS PER STANDARD NORMS.

17. STATIC ELECTRICITY DISCHARGERS SHOULD BE PROVIDED WHEREVER NECESSARY.

18. RATE SHOULD BE QUOTED SEPARATELY FOR SUPPLY AND SERVICE LIKE INTEGRATION, TESTING AND COMMISSIONING OF ONE SUCH SYSTEM AS PER PRICE SCHEDULE .BILL OF MATERIALS SHOULD BE PROVIDED SEPARATELY IN SUPPORT TO THE SUPPLY.

19. COMMISSIONING: COMMISSIONING OF THE SYSTEM OR ANY PART THEREOF SHALL BE COMMENCED BY THE BIDDER IMMEDIATELY AFTER RECEIPT OF INTIMATION FROM HLL. HLL SHALL SUPPLY THE OPERATING PERSONNEL AND ALL RAW MATERIALS, UTILITIES, LUBRICANTS, CHEMICALS SERVICES AND OTHER MATTERS REQUIRED FOR COMMISSIONING.

20. **PERFORMANCE TEST:** THE PERFORMANCE TEST SHALL BE CONDUCTED BY THE BIDDER DURING THE COMMISSIONING OF THE SYSTEM TO ASCERTAIN WHETHER THE SYSTEM CAN ATTAIN THE FUNCTIONAL GUARANTEES SPECIFIED IN THE TECHNICAL SPECIFICATION.
21. **OPERATIONAL ACCEPTANCE:** OPERATIONAL ACCEPTANCE SHALL OCCUR IN RESPECT OF THE SYSTEM WHEN THE PERFORMANCE TEST HAS BEEN SUCCESSFULLY COMPLETED AND THE FUNCTIONAL PERFORMANCES ARE MET.
22. PERIOD WARRANTY SHALL BE 12 MONTHS FROM THE DATE OF INSTALLATION AND COMMISSIONING AS CERTIFIED JOINTLY BY THE SUPPLIER AND THE PURCHASER.
23. THE BIDDER SHALL ATTEND THE PRE-BID CONFERENCE ARRANGED BY HLL BEFORE SUBMITTING THE OFFER.
24. THREE COPIES OF INSTRUCTION/OPERATIONAL MANUAL (ESPECIALLY FOR BROUGHT OUT ITEMS) AND MAINTENANCE MANUAL SHOULD BE SUPPLIED ALONG WITH THE MACHINE.
25. A LIST OF SPARE PARTS SHOULD BE PROVIDED. A MINIMUM SET OF SPARE PARTS SHOULD BE PROVIDED FOR EACH MACHINE.
26. BROUGHT OUT ITEMS SUCH AS ELECTRICAL/ELECTRONIC ITEMS, ELECTRIC HEAT BANKS ETC SHOULD BE AS PER RELEVANT INDIAN STANDARDS APPROVED CERTIFICATIONS.

**SCHEDULE IV**  
**ACCEPTANCE FORM**

*(To be submitted in the letter pad of the firm indicating full name and address, telephone & fax numbers etc.)*

From

To

Associate Vice President (CED)  
Central Engineering Division,  
HLL Lifecare Limited (A Government of India Enterprise),  
PB No 2, Peroorkada, Thiruvananthapuram – 695005,  
Kerala State, India  
Ph: (++91 471) 2433374,2437270 –501,502  
Tele Fax: (++ 91 471) 2432647  
E-mail: srnair@lifecarehll.com, rajeevrv@lifecarehll.com

Dear Sir,

I / We, hereby offer to supply materials as detailed in schedule here to or such portion thereof as you may specify in the acceptance of Bid at the price given in the price bid and agree to hold this offer open till 90 days after the date of bid opening prescribed by the purchaser. I/We have understood the terms and conditions mentioned in the invitation for bid and Conditions of Contract furnished by you and have thoroughly examined the specifications and drawings in the bid document hereto and are fully aware of the nature of the scope of supply and my/our offer is to comply strictly in accordance with the requirement and the terms and conditions mentioned above. I/We have understood that the PURCHASER is the sole owner of the technology, equipment, specification and drawings given along with the bidding documents. I/we here by assure that the above information will be kept confidential and will not be used for any other purpose or will not be transferred to third party.

Yours faithfully,

## SCHEDULE V

### **SCHEDULE FOR SUPPLY INSTALLATION, INTEGRATION, TESTING AND COMMISSIONING OF ON LINE POWDER FINISHING SYSTEM FOR THE BTADL CONDOM DIPPING MACHINE AT KANAGALA.**

Sl.No.	Item description	Unit	Qty.	Rate/set	Amount
1.	Supply of Online Powder Finishing Operation with dehydrator System for BTADL Condom Dipping Machine at Kanagala , Belgaum	SET	2		
	Basic price in Rs.				
	Excise duty in Rs.				
	Cess on excise duty				
	CST/VAT (% to be furnished)				
	Freight				
	Insurance				
	Installation, Integration, Testing and Commissioning Charges.				
	Others, if any (please specify)				
	Total delivered rate at HLL				

**(In words)**

I agree to complete the SITC as per schedule at the rates quoted by me as above and the terms and conditions of the tender document.

**SIGNATURE OF THE BIDDER**





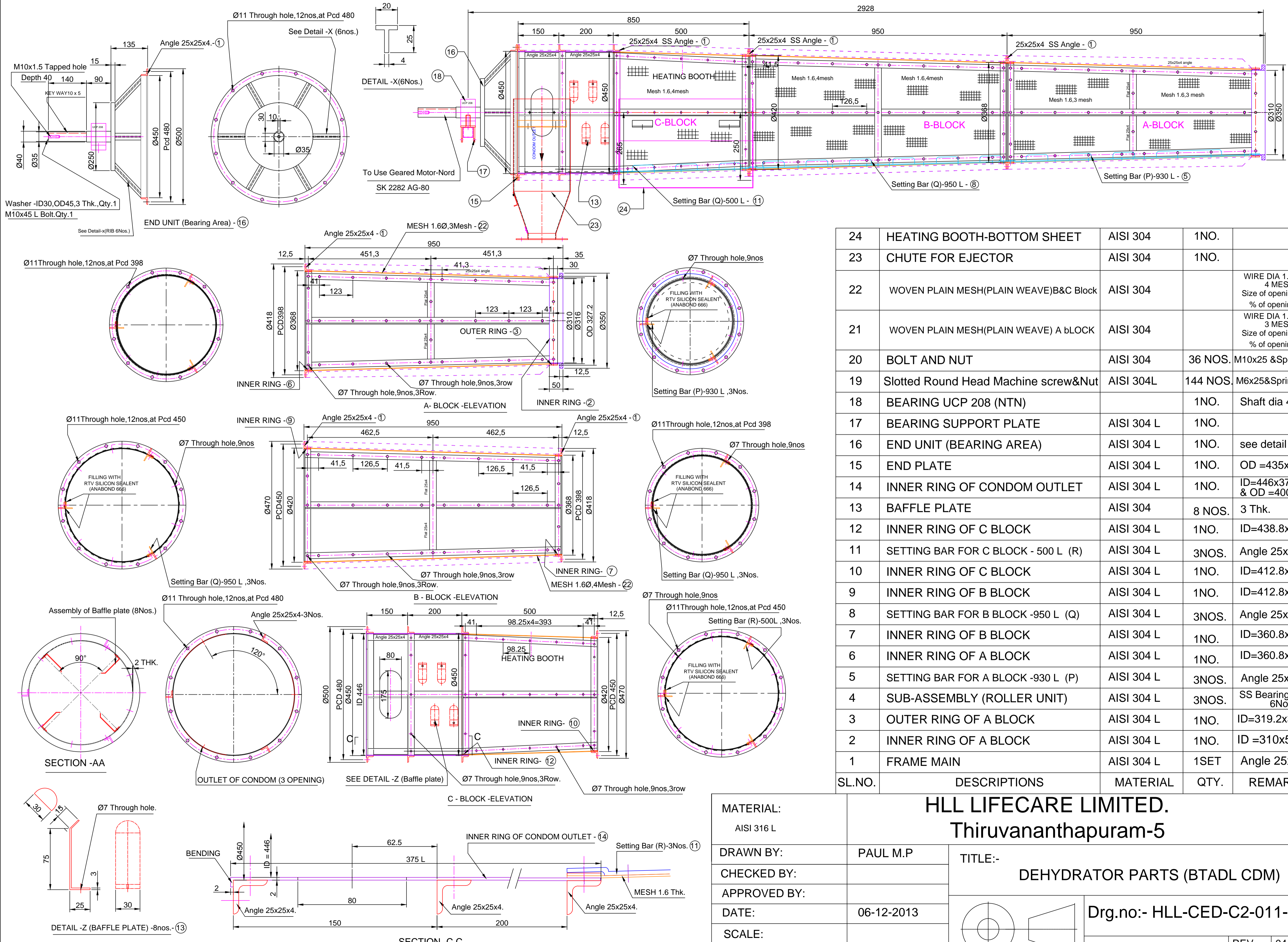

SL.NO.	DESCRIPTIONS	MATERIAL	QTY.	REMARKS
24	HEATING BOOTH-BOTTOM SHEET	AISI 304	1NO.	
23	CHUTE FOR EJECTOR	AISI 304	1NO.	
22	WOVEN PLAIN MESH(PLAIN WEAVE)B&C Block	AISI 304		WIRE DIA 1.626-16SWG 4 MESH Size of opening - 6.843mm % of opening -65.3
21	WOVEN PLAIN MESH(PLAIN WEAVE) A bLOCK	AISI 304		WIRE DIA 1.626-16SWG 3 MESH Size of opening - 6.843mm % of opening -65.3
20	BOLT AND NUT	AISI 304	36 NOS.	M10x25 & Spring washer
19	Slotted Round Head Machine screw&Nut	AISI 304L	144 NOS.	M6x25&Spring washer
18	BEARING UCP 208 (NTN)		1NO.	Shaft dia 40
17	BEARING SUPPORT PLATE	AISI 304 L	1NO.	
16	END UNIT (BEARING AREA)	AISI 304 L	1NO.	see detail no. 13
15	END PLATE	AISI 304 L	1NO.	OD =435x1.6 Thk.
14	INNER RING OF CONDOM OUTLET	AISI 304 L	1NO.	ID=446x375 Lx2Thk. & OD =400x2Thk.
13	BAFFLE PLATE	AISI 304	8 NOS.	3 Thk.
12	INNER RING OF C BLOCK	AISI 304 L	1NO.	ID=438.8x25x2Thk.
11	SETTING BAR FOR C BLOCK - 500 L (R)	AISI 304 L	3NOS.	Angle 25x25x3Thk.
10	INNER RING OF C BLOCK	AISI 304 L	1NO.	ID=412.8x25x2Thk.
9	INNER RING OF B BLOCK	AISI 304 L	1NO.	ID=412.8x25x2Thk.
8	SETTING BAR FOR B BLOCK -950 L (Q)	AISI 304 L	3NOS.	Angle 25x25x3Thk.
7	INNER RING OF B BLOCK	AISI 304 L	1NO.	ID=360.8x25x2Thk.
6	INNER RING OF A BLOCK	AISI 304 L	1NO.	ID=360.8x25x2Thk.
5	SETTING BAR FOR A BLOCK -930 L (P)	AISI 304 L	3NOS.	Angle 25x25x3Thk.
4	SUB-ASSEMBLY (ROLLER UNIT)	AISI 304 L	3NOS.	SS Bearing 6001 zz 6Nos.
3	OUTER RING OF A BLOCK	AISI 304 L	1NO.	ID=319.2x30x4 Thk.
2	INNER RING OF A BLOCK	AISI 304 L	1NO.	ID =310x50x3 Thk.
1	FRAME MAIN	AISI 304 L	1SET	Angle 25x25x4

**MATERIAL:**  
AISI 316 L

**HLL LIFECARE LIMITED.**  
Thiruvananthapuram-5

**DRAWN BY:** PAUL M.P

**CHECKED BY:**

**APPROVED BY:**

**DATE:** 06-12-2013

**SCALE:**

**ALL DIMENSIONS ARE IN M.M**

**TITLE:-**  
DEHYDRATOR PARTS (BTADL CDM)

**Drg.no:-** HLL-CED-C2-011-00

**SHEET NO:** 2 OF 3

**REV. 04**  
**DATE:** 29-05-2014







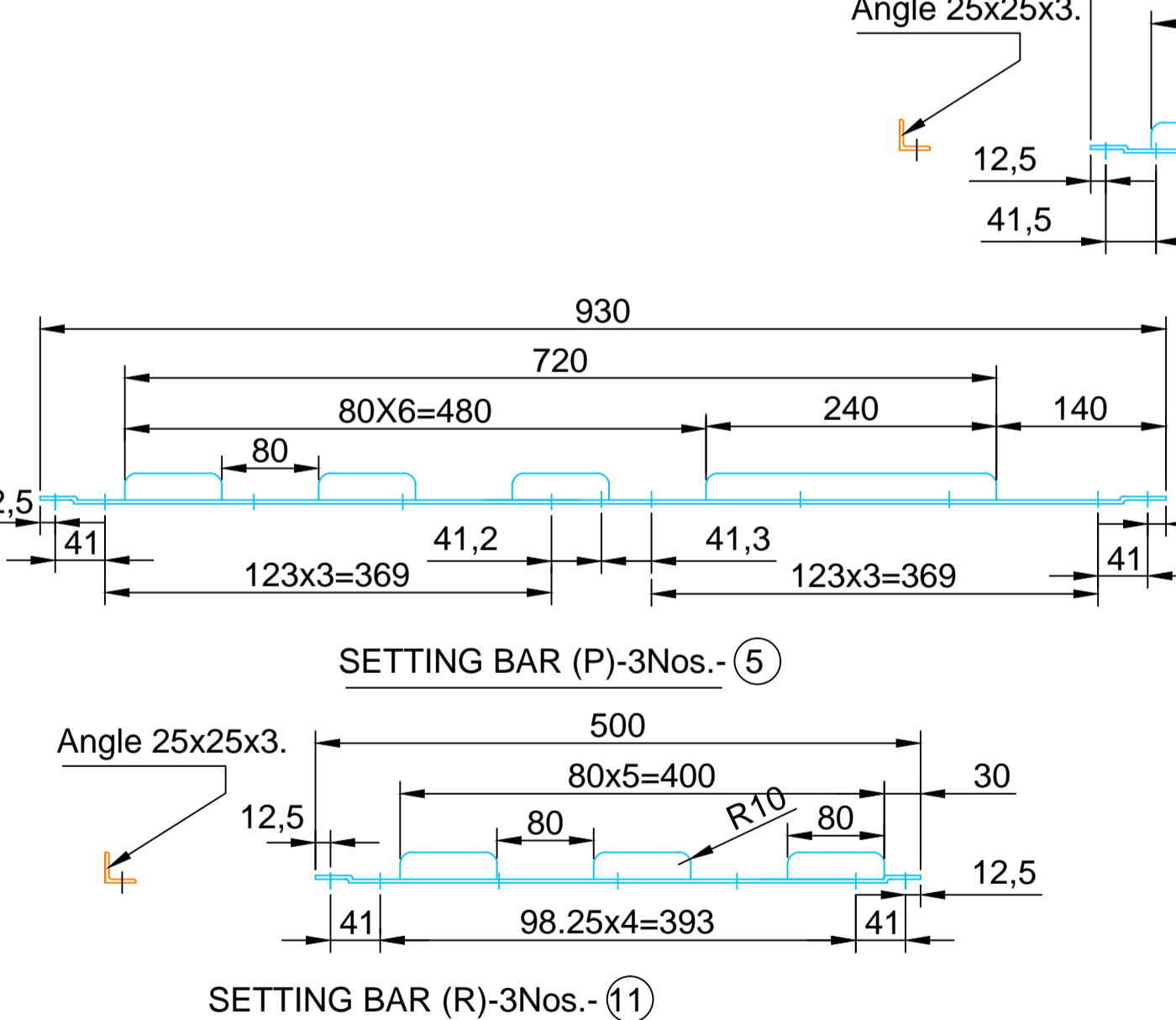
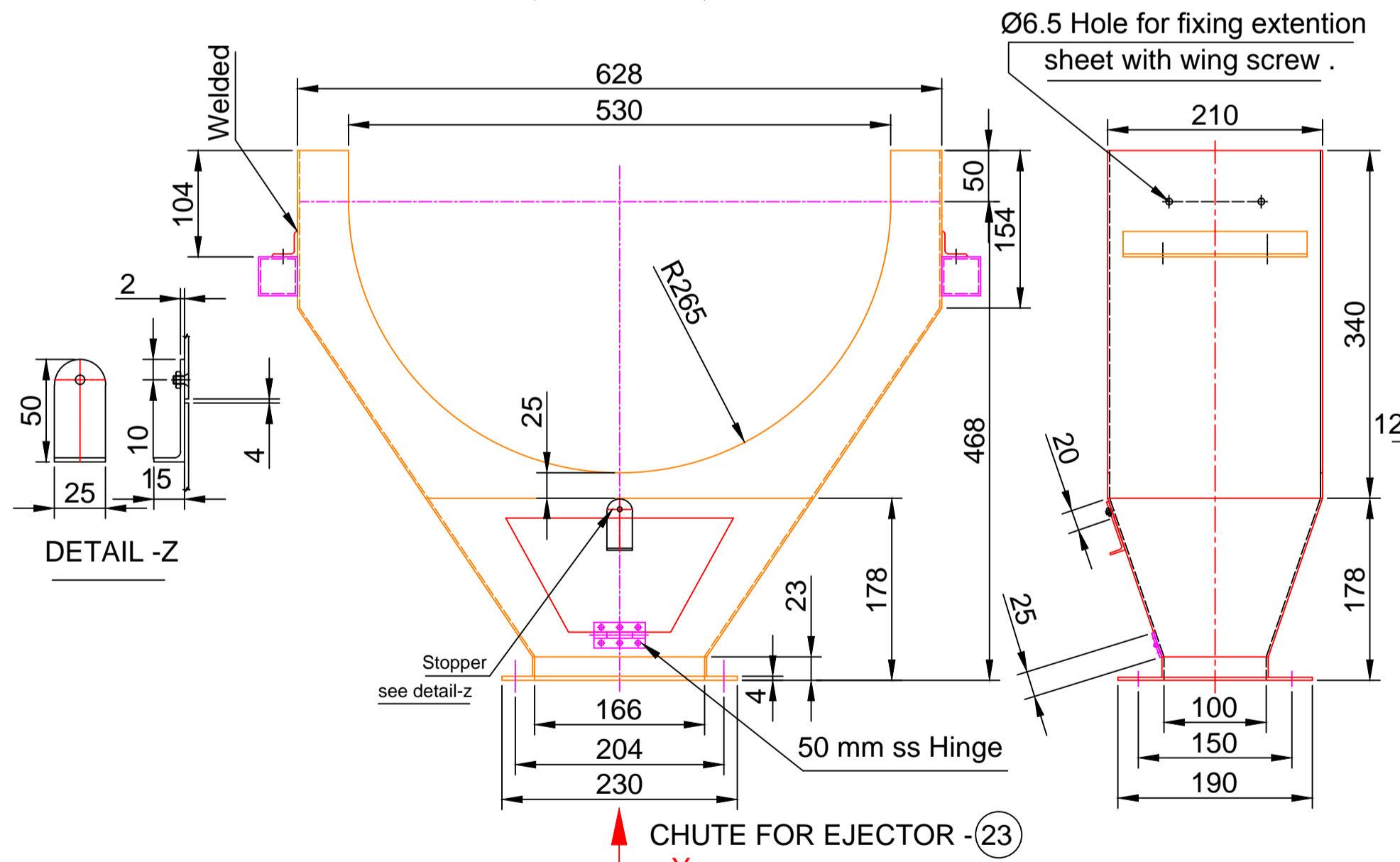
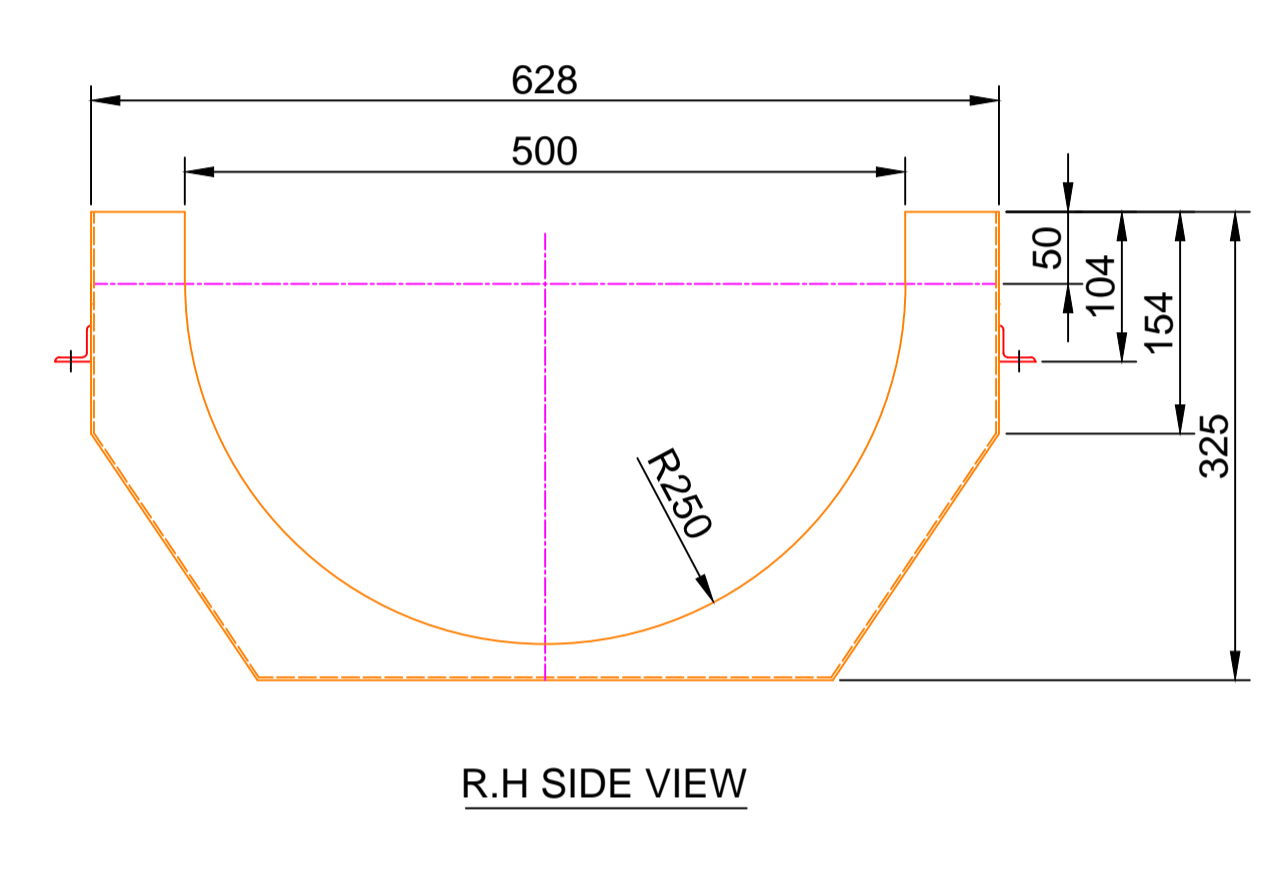
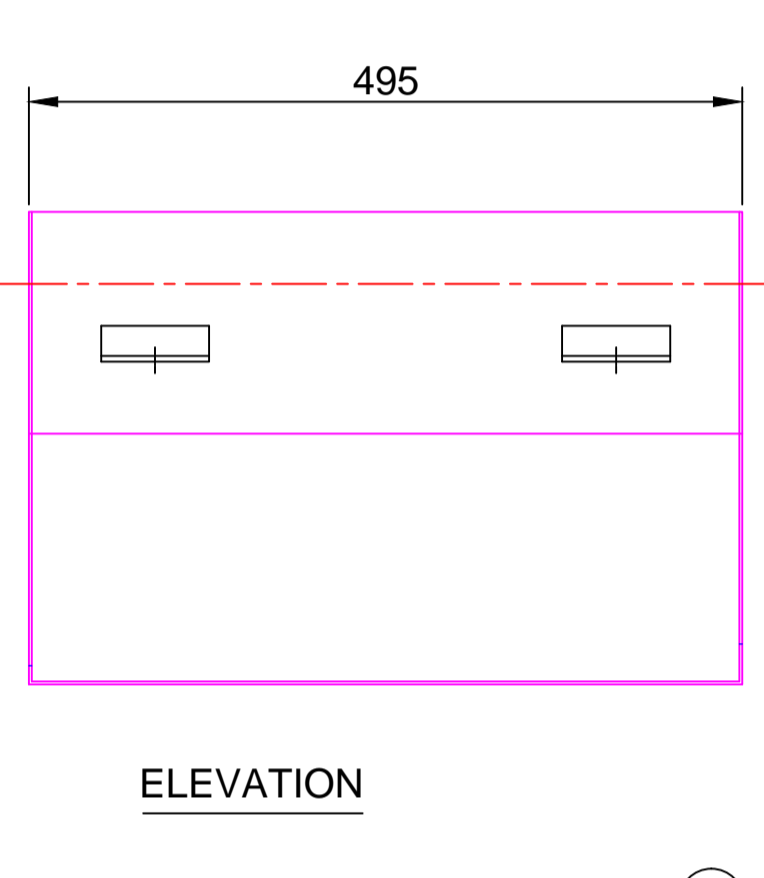
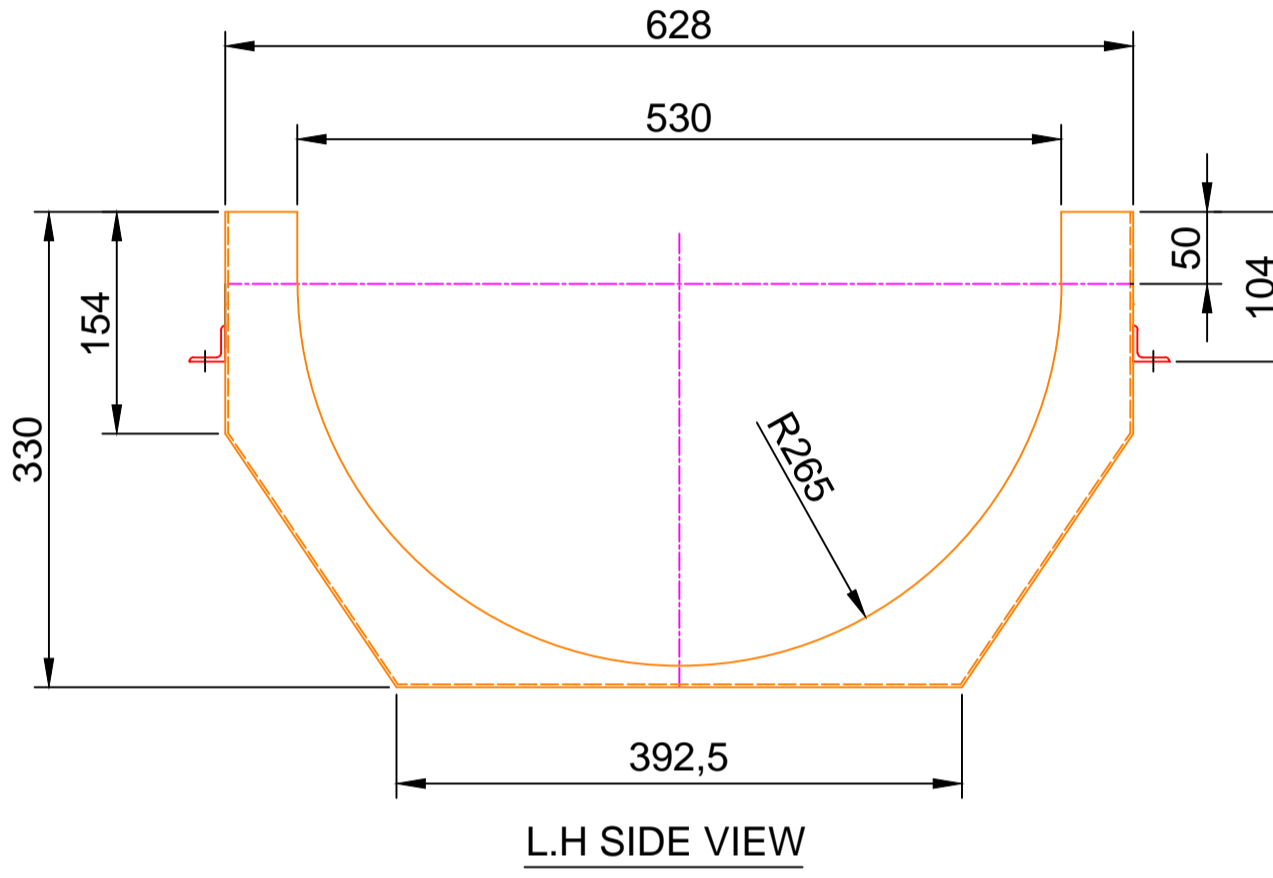
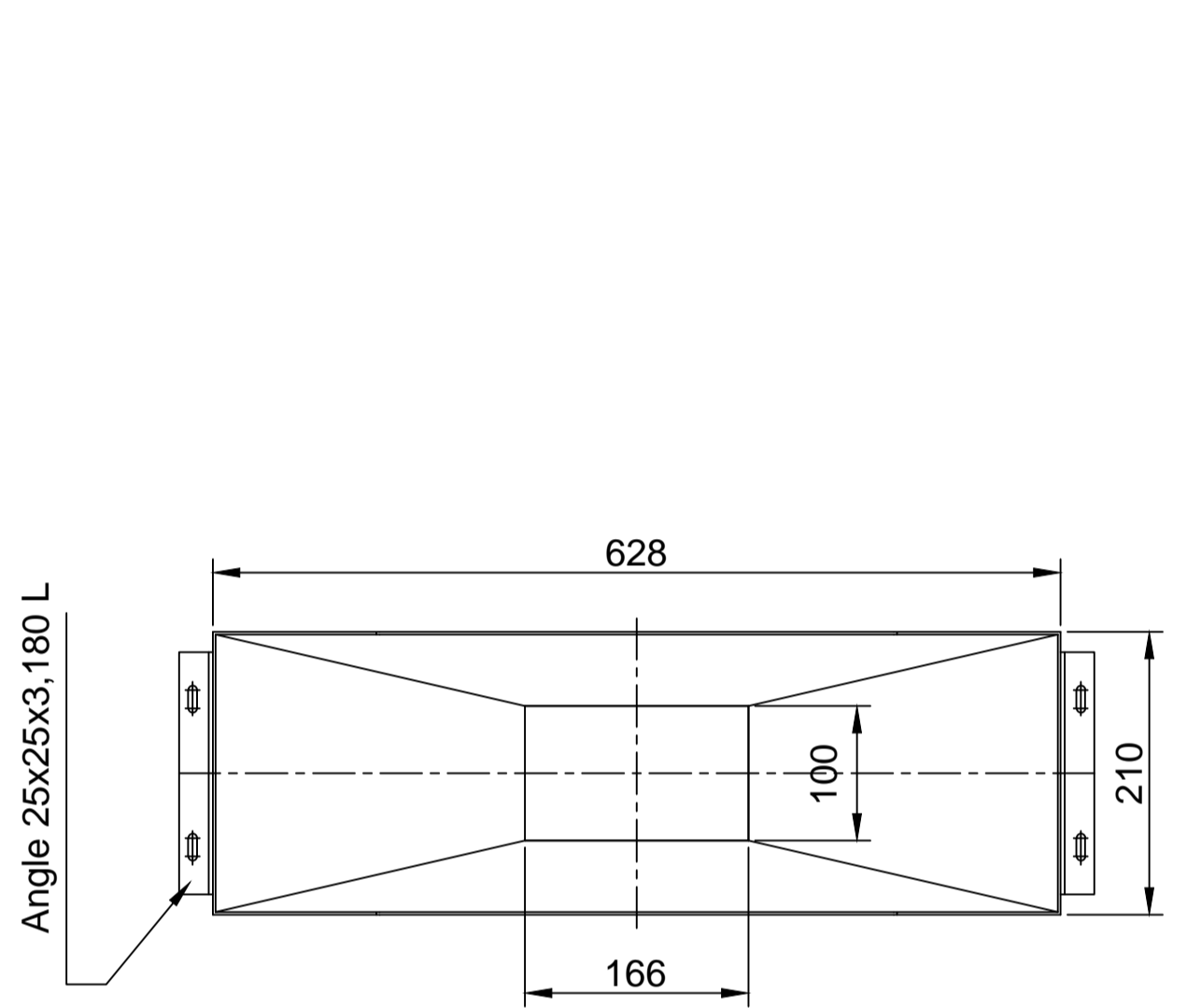
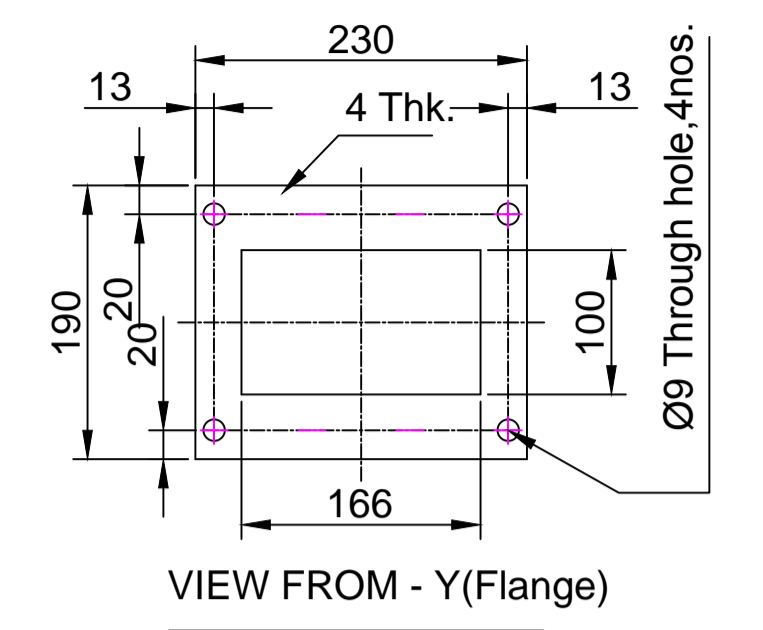
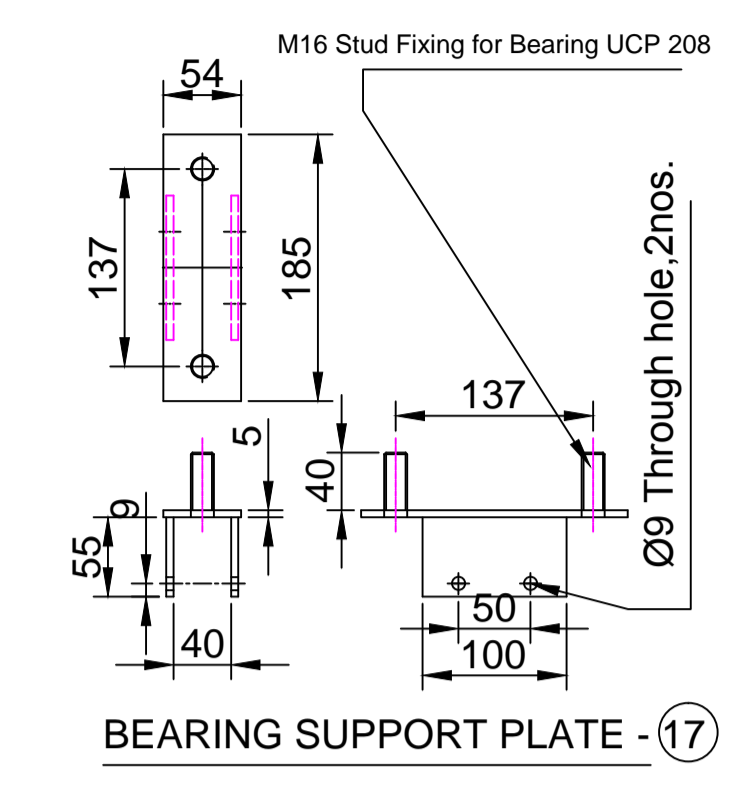
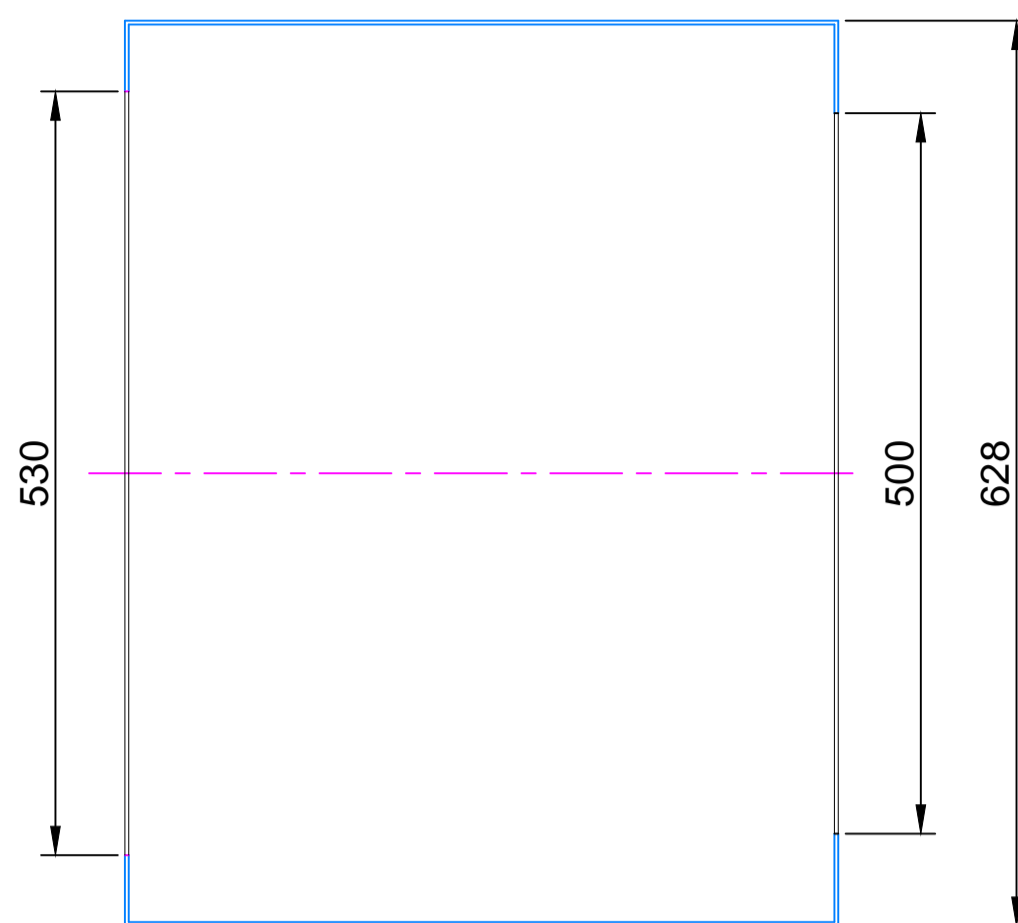
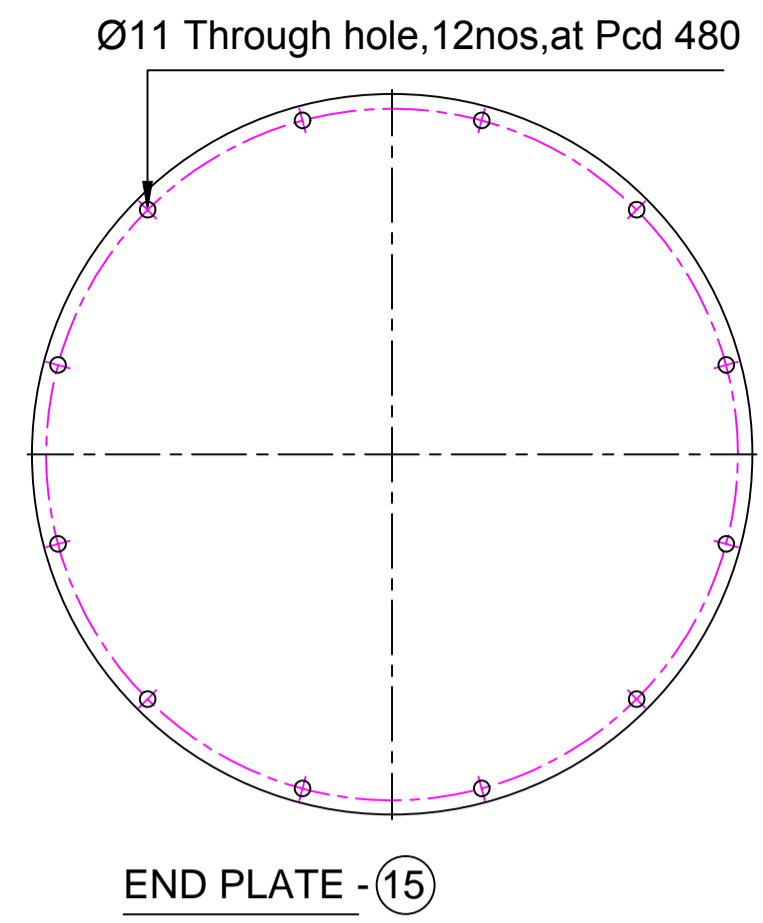
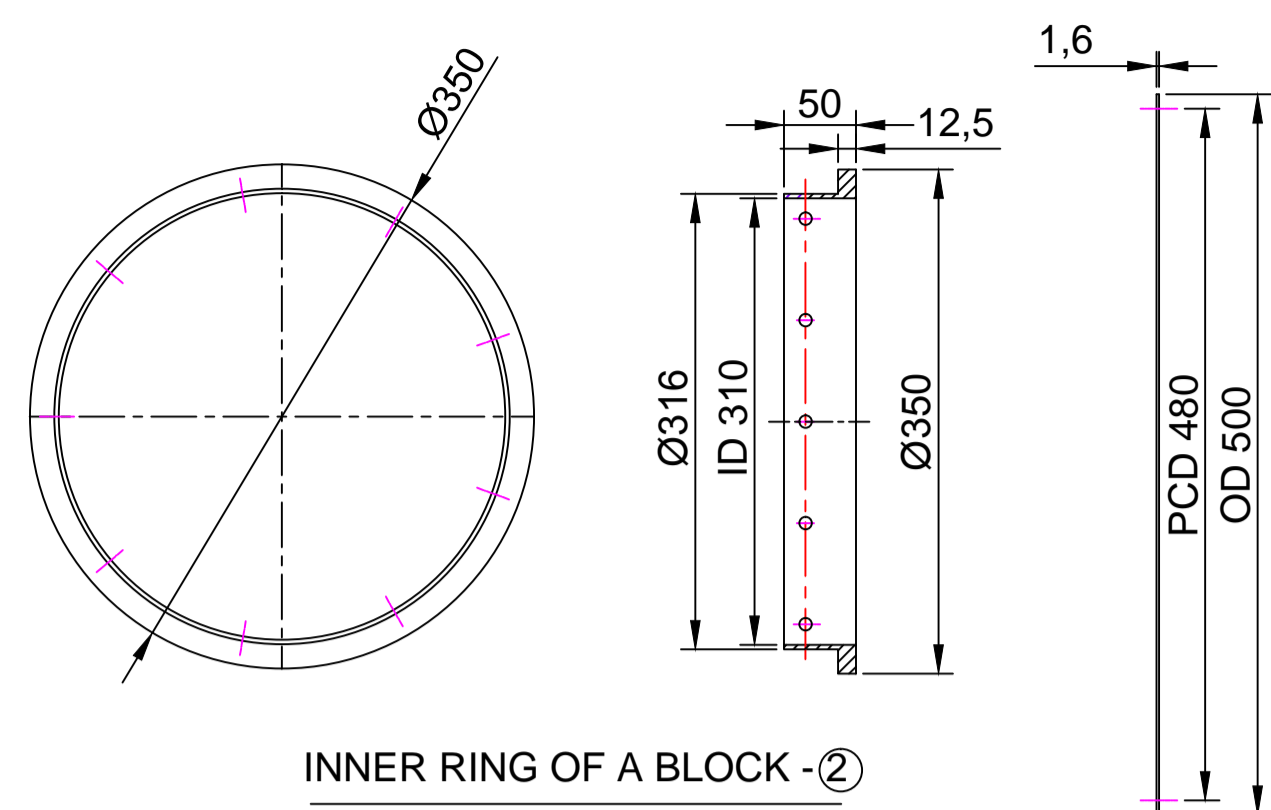

- NOTE :-
- \* ALL WELDING SHOULD BE DONE USING TIG WELDING
  - \* UNIT SHOULD BE IN ASSEMBLED STAGE WITH BEARING AND ALL SS FASTENERS (APL/TVS/UNBROKO) - WHEREVER NECESSARY.
  - \* Bearing no.UCP 208, 1no.(NTN/SKF) & Bearing 6001zz(Mat: Aisi 316 (2nos.per Roller)
  - \* "STATIC BALANCE" TO BE DONE THE WHOLE ASSEMBLY
  - \* WELDING JOINTS SHALL BE FINISHED WITH GRINDING/ BUFFING

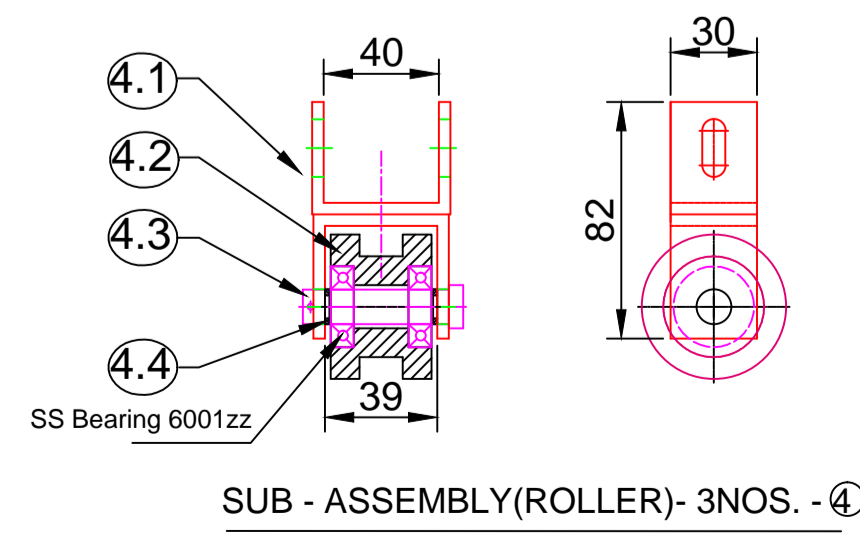
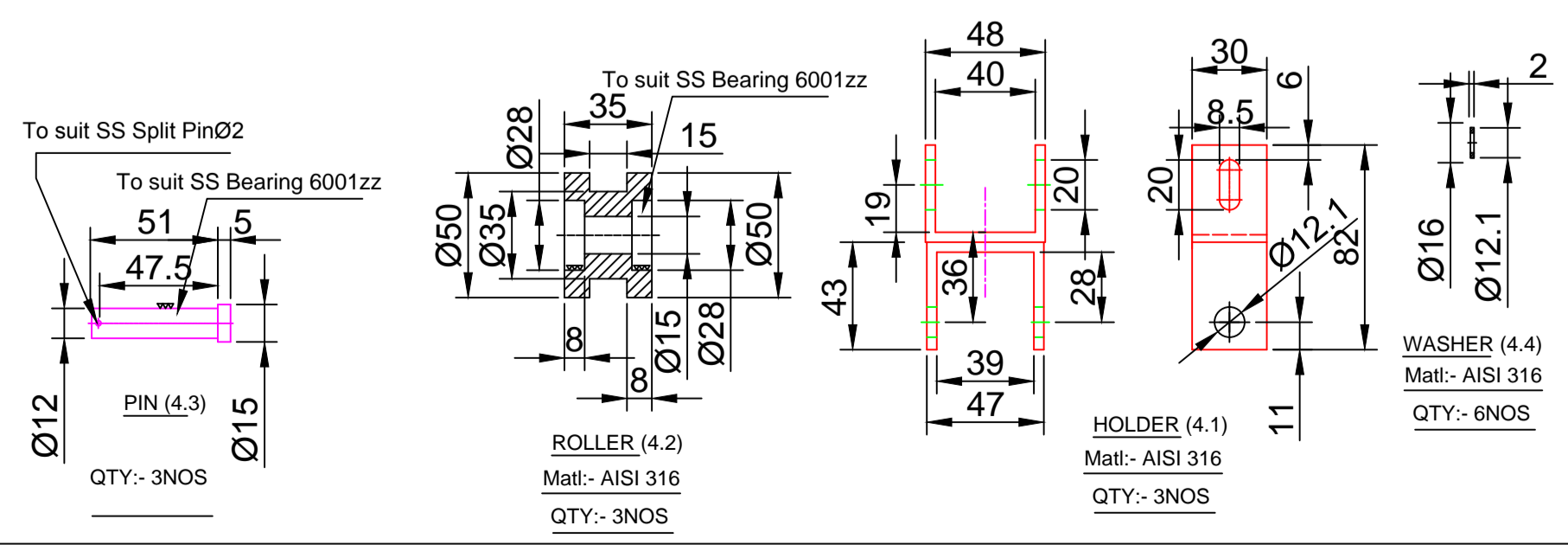

MATERIAL: AISI 316 L (IS 1570-07 Cr19Ni9Mo2Ti28)	<b>HLL LIFECARE LIMITED.</b> <b>Thiruvananthapuram-5</b>		NO:OFF.
DRAWN BY: PAUL M.P	TITLE:- DEHYDRATOR PARTS (BTADL CDM)		
CHECKED BY:			
APPROVED BY:			
DATE: 06-12-2013			Drg.no:- HLL-CED-C2-011-00
SCALE: ALL DIMENSIONS ARE IN M.M			SHEET NO: 3 OF 3

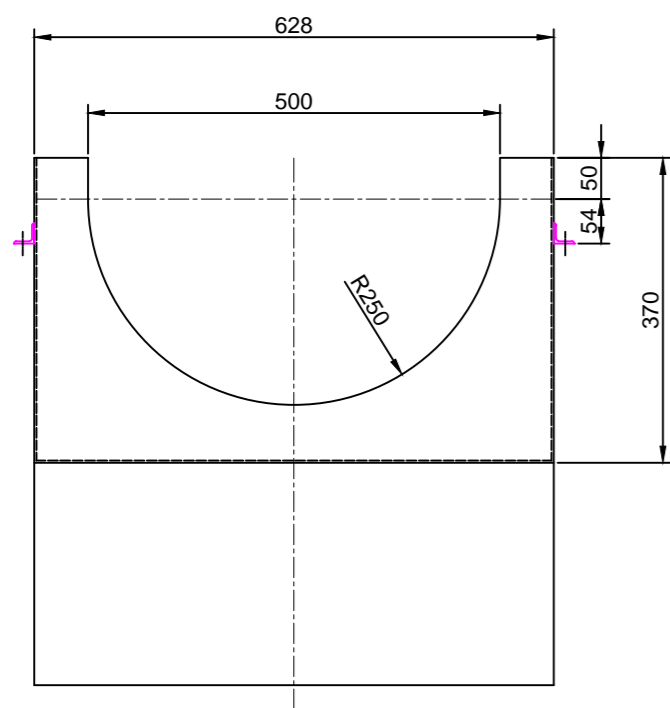
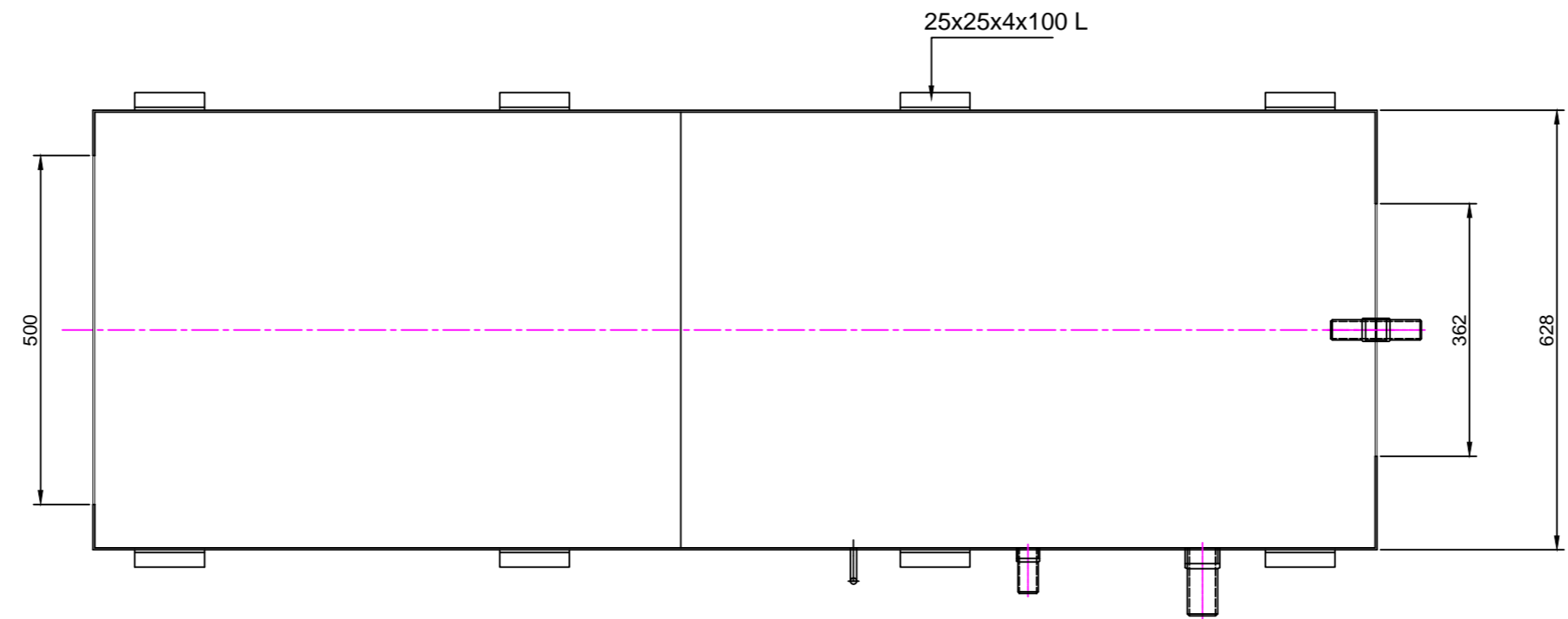

L.SIDE VIEW

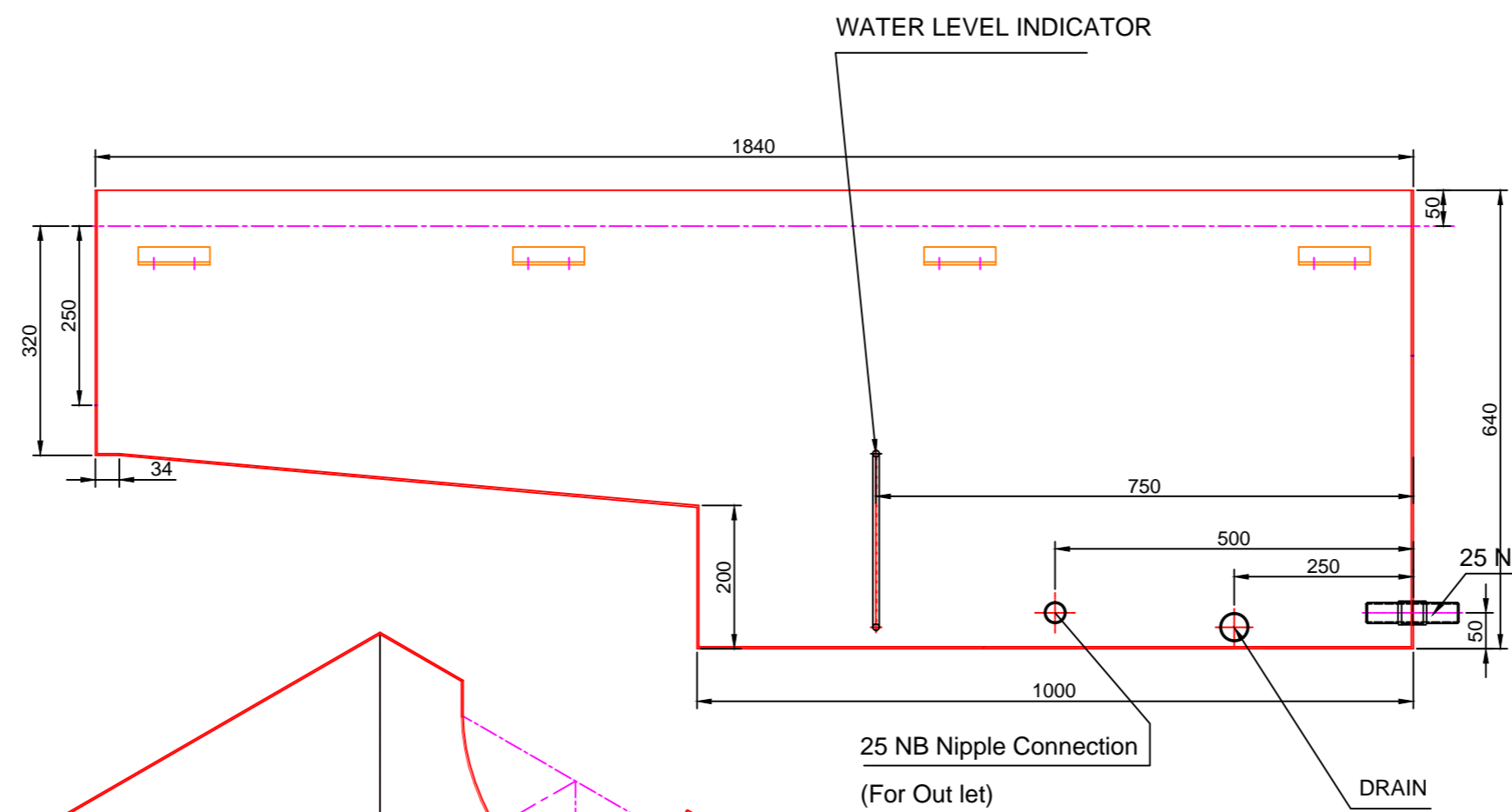

ELEVATION

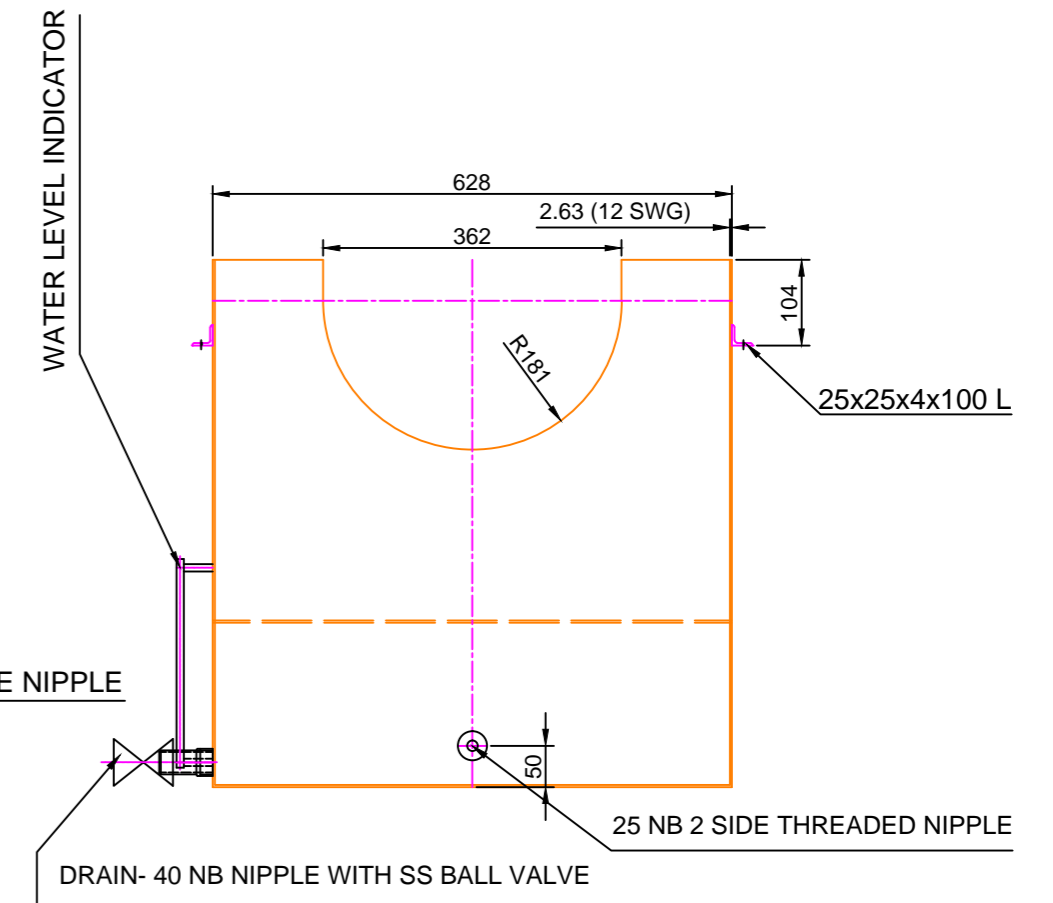

R.SIDE VIEW

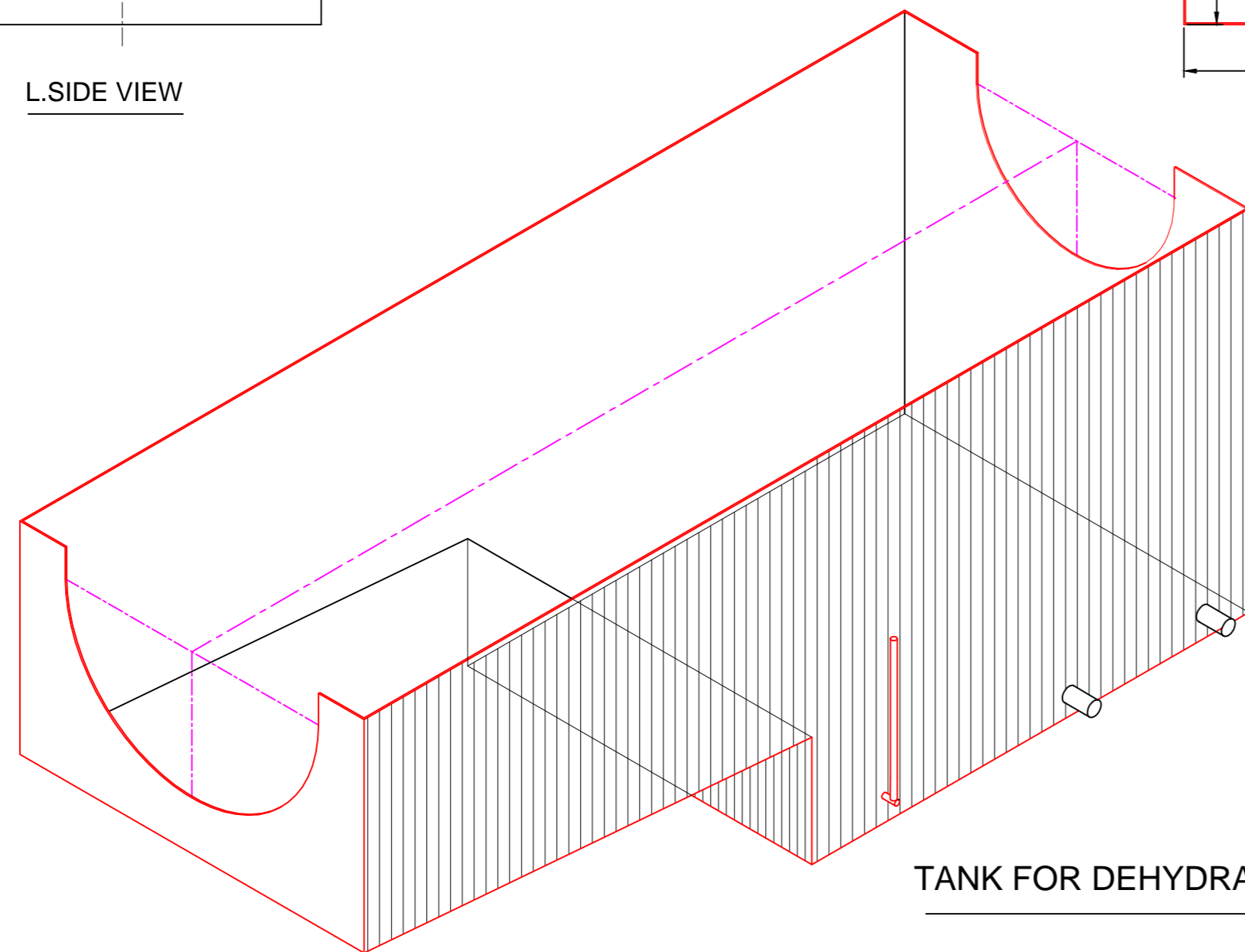

TANK FOR DEHYDRATOR

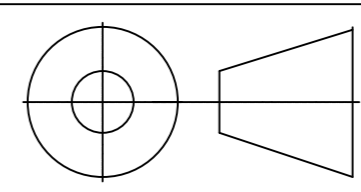
MATERIAL: AISI 316 L (IS 1570-07 Cr19Ni9Mo2Ti28)	<b>HLL LIFECARE LIMITED.</b> <b>Thiruvananthapuram-5</b>		NO:OFF.
DRAWN BY:	PAUL M.P	TITLE:- TANK FOR DEHYDRATOR (BTADL CDM)	
CHECKED BY:		Drg.no:- HLL-CED-C2-011-01	
APPROVED BY:			
DATE:	06-12-2013		
SCALE:			
ALL DIMENSIONS ARE IN M.M		SHEET NO: 1 OF 1	REV:- DATE:-07-05-2014

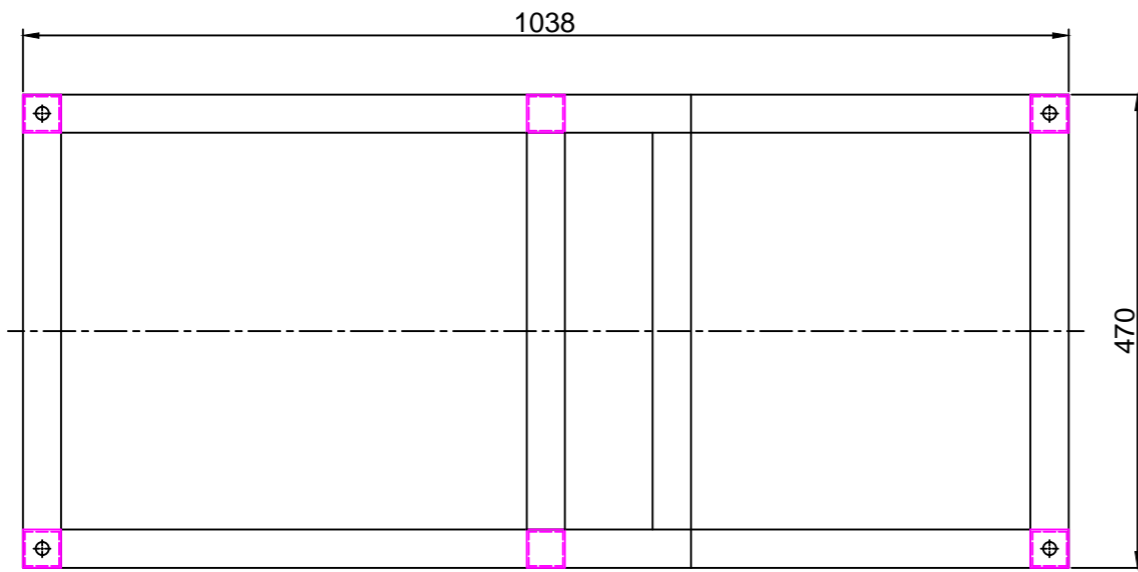

PLAN

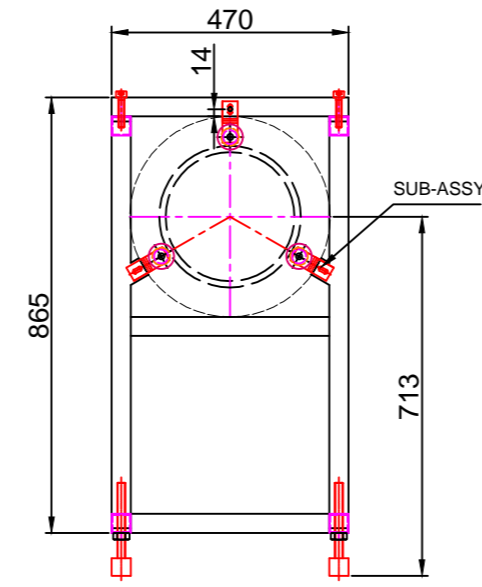

ASSEMBLY WITH ROLLER - SIDE VIEW

SCALE 1:2

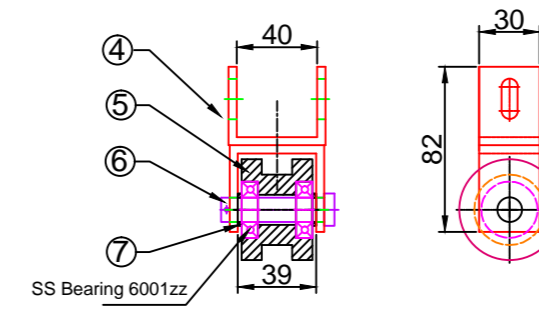

SUB - ASSEMBLY (ROLLER)

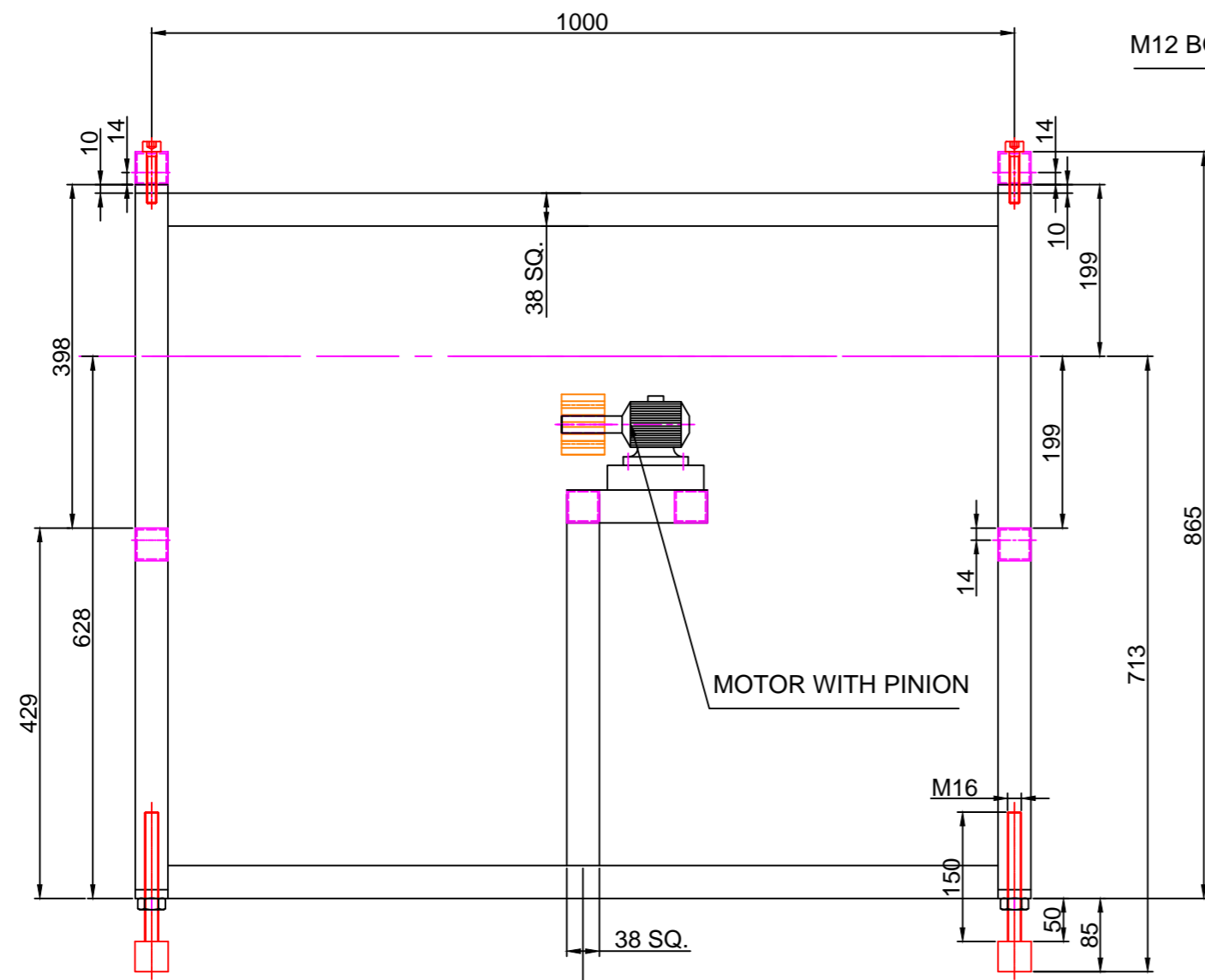

ELEVATION

M12 BOLT, 4 NOS, 60 L.

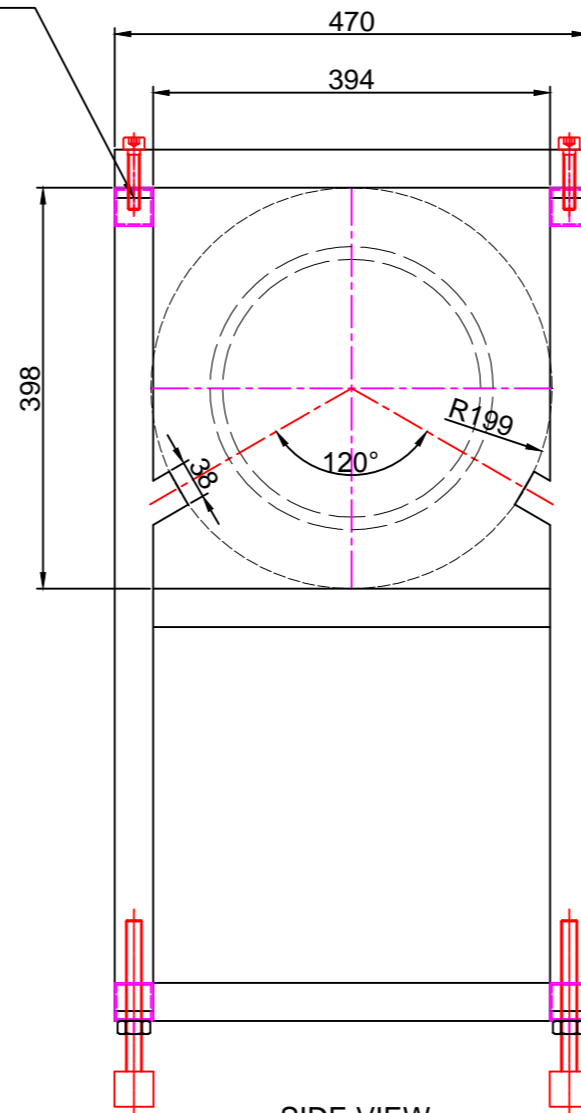

SIDE VIEW

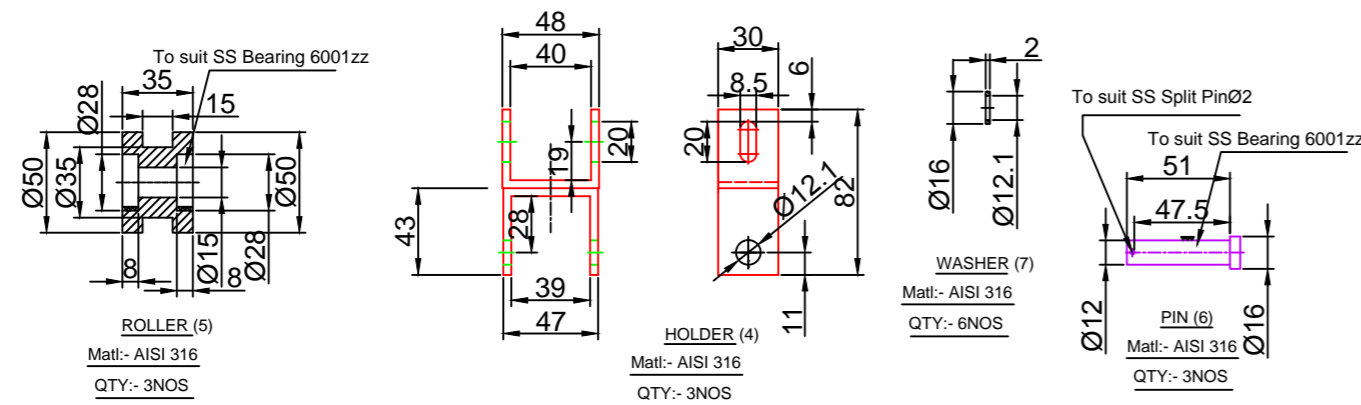
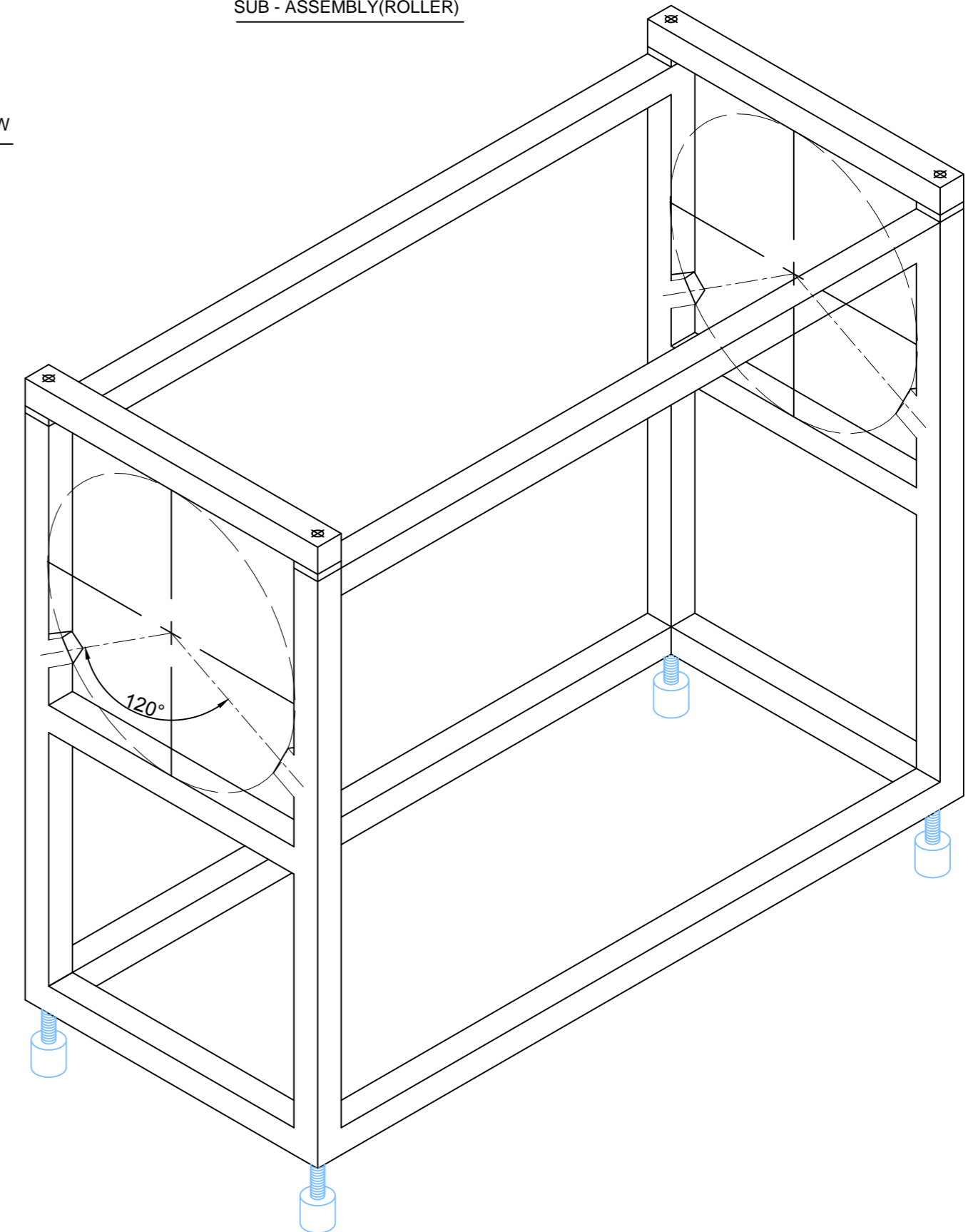

ROLLER (5)  
Matl:- AISI 316  
QTY:- 3NOS

HOLDER (4)  
Matl:- AISI 316  
QTY:- 3NOS

WASHER (7)  
Matl:- AISI 316  
QTY:- 6NOS

PIN (6)  
Matl:- AISI 316  
QTY:- 3NOS

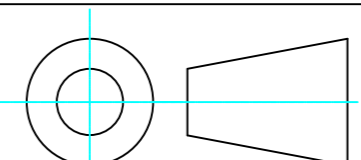
MATERIAL: AISI 316 L	<b>HLL Lifecare Limited.</b> <b>Thiruvananthapuram-5</b>		NO:OFF.
DRAWN BY: CHECKED BY: APPROVED BY:	PAUL M P	TITLE:- FRAME FOR SCREW CONVEYOR (BTADL CDM)	
DATE: SCALE:	05-12-2013		Drg .no:- HLL -CED - C2 -010-01
ALL DIMENSIONS ARE IN M.M			SHEET.NO:-1OFF.1



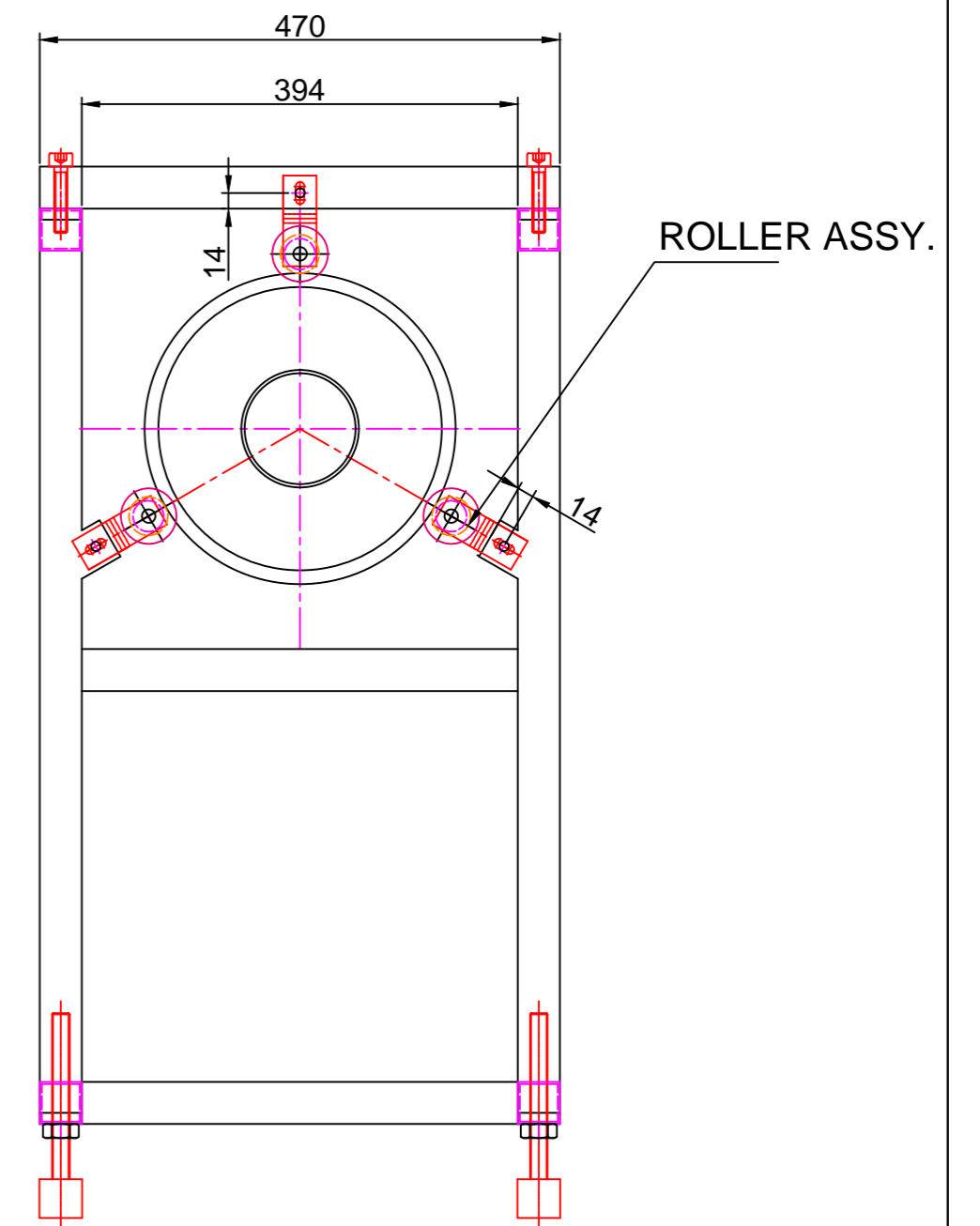
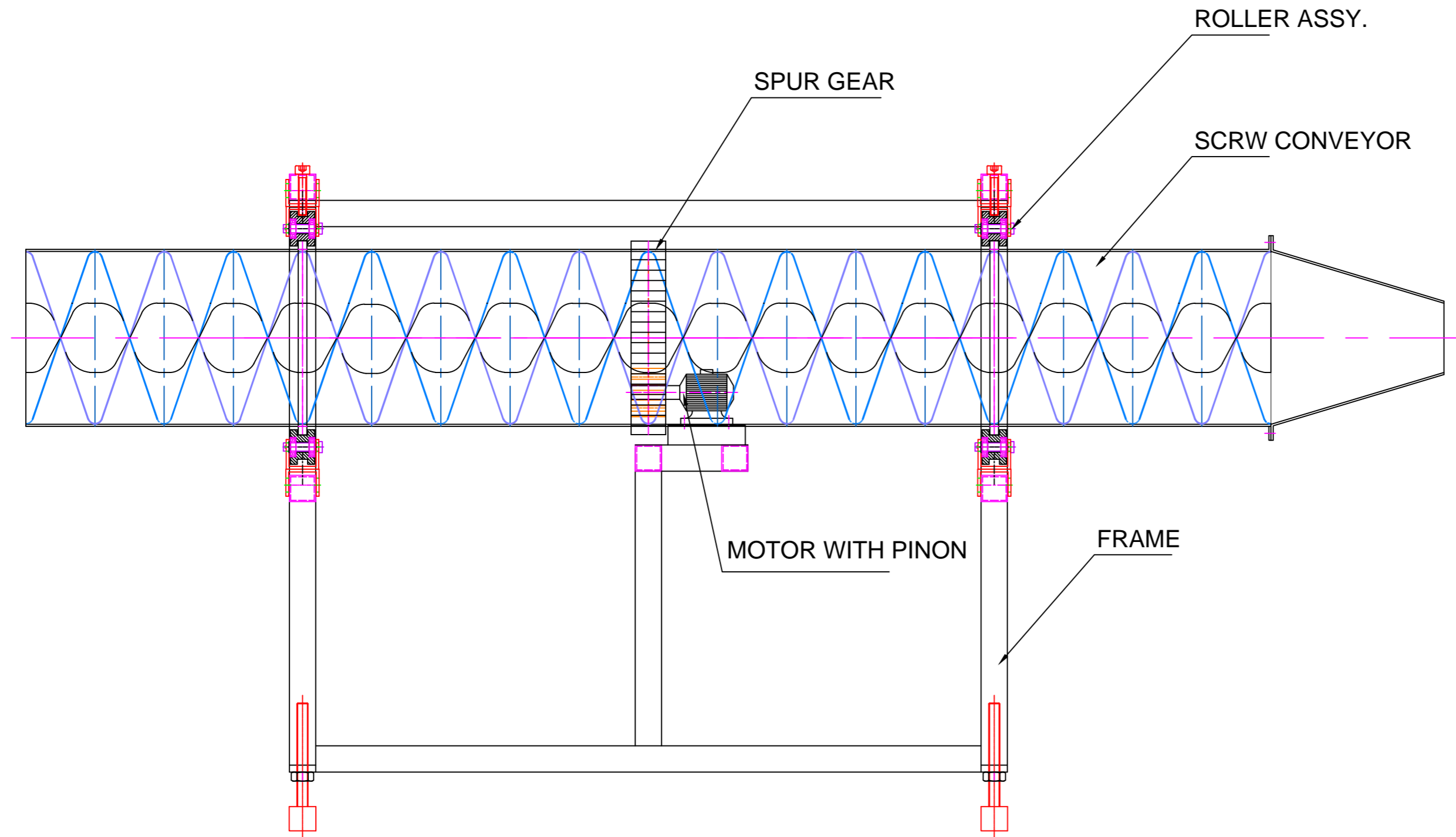
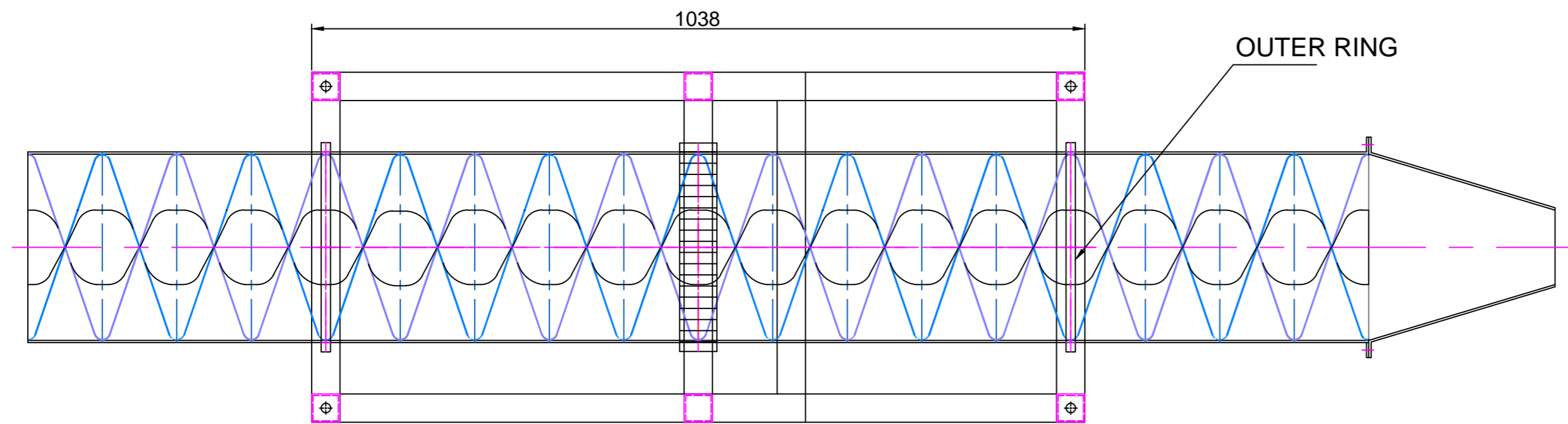

MATERIAL: AISI 316 L	<b>HLL Lifecare Limited.</b> <b>Thiruvananthapuram-5</b>		NO:OFF.
DRAWN BY: PAUL M P	TITLE:- ASSEMBLY FOR SCREW CONVEYOR (BTADL CDM)		
CHECKED BY:			Drg .no:- HLL -CED - C2 -010-00
APPROVED BY:			SHEET.NO:-1OFF.1
DATE: 05-12-2013			REV:-01
SCALE:			DATE:- 13-05-2014
ALL DIMENSIONS ARE IN M.M			

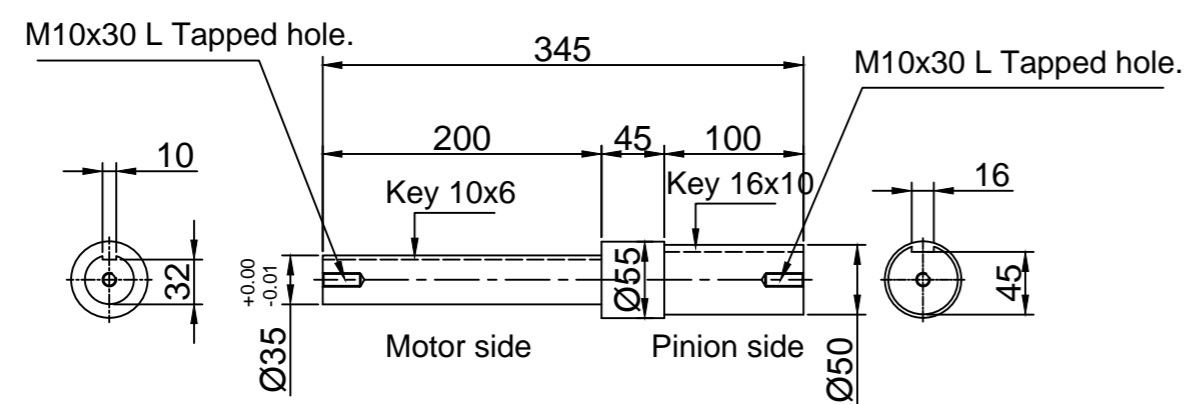
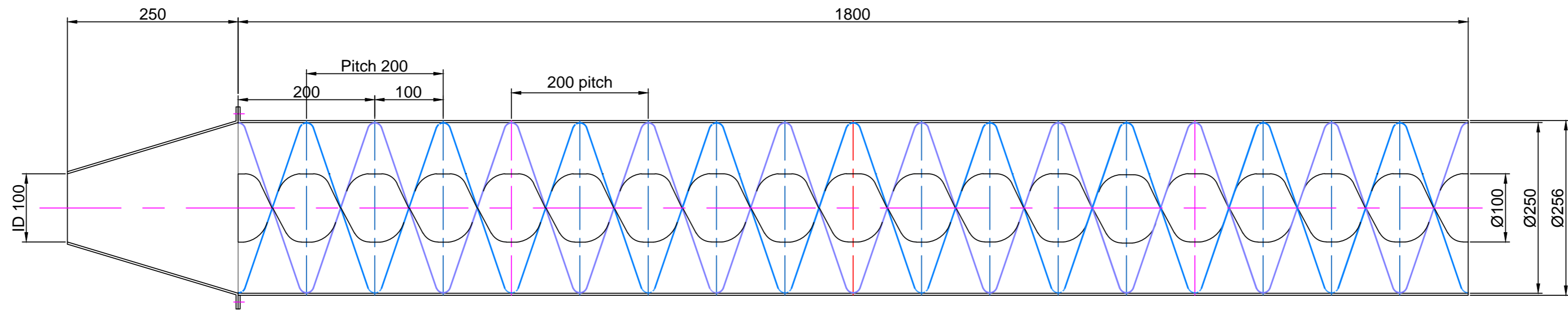

**SHAFT**  
Qty:-1no.

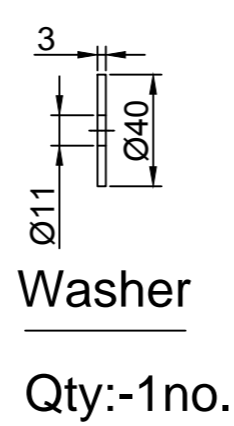

**Washer**  
Qty:-1no.

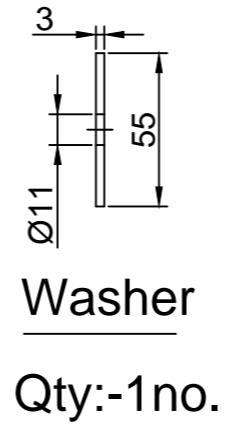

**Washer**  
Qty:-1no.

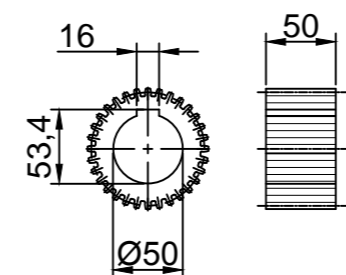

**PINION**

PITCH = 8 MM  
N T=32Nos.  
P.C.D = 81.45  
OD = 86.45  
Material:- Peek,Qty. 1no.

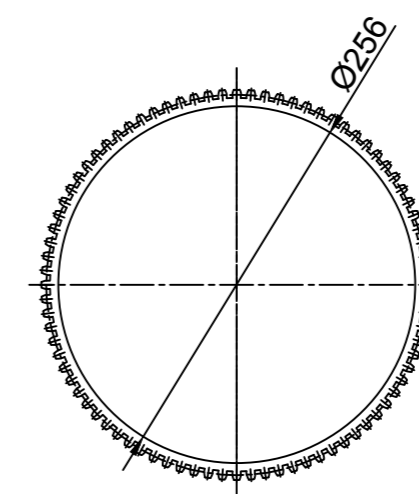

**SPUR GEAR**

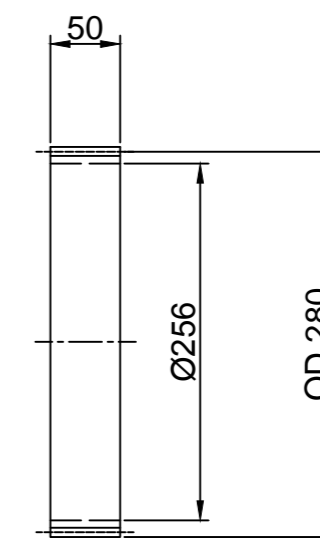

PITCH = 8 MM  
NO:OF: TEETH = 84  
P.C.D = 273 MM  
OD = 280 MM  
MATERIAL = PEEK

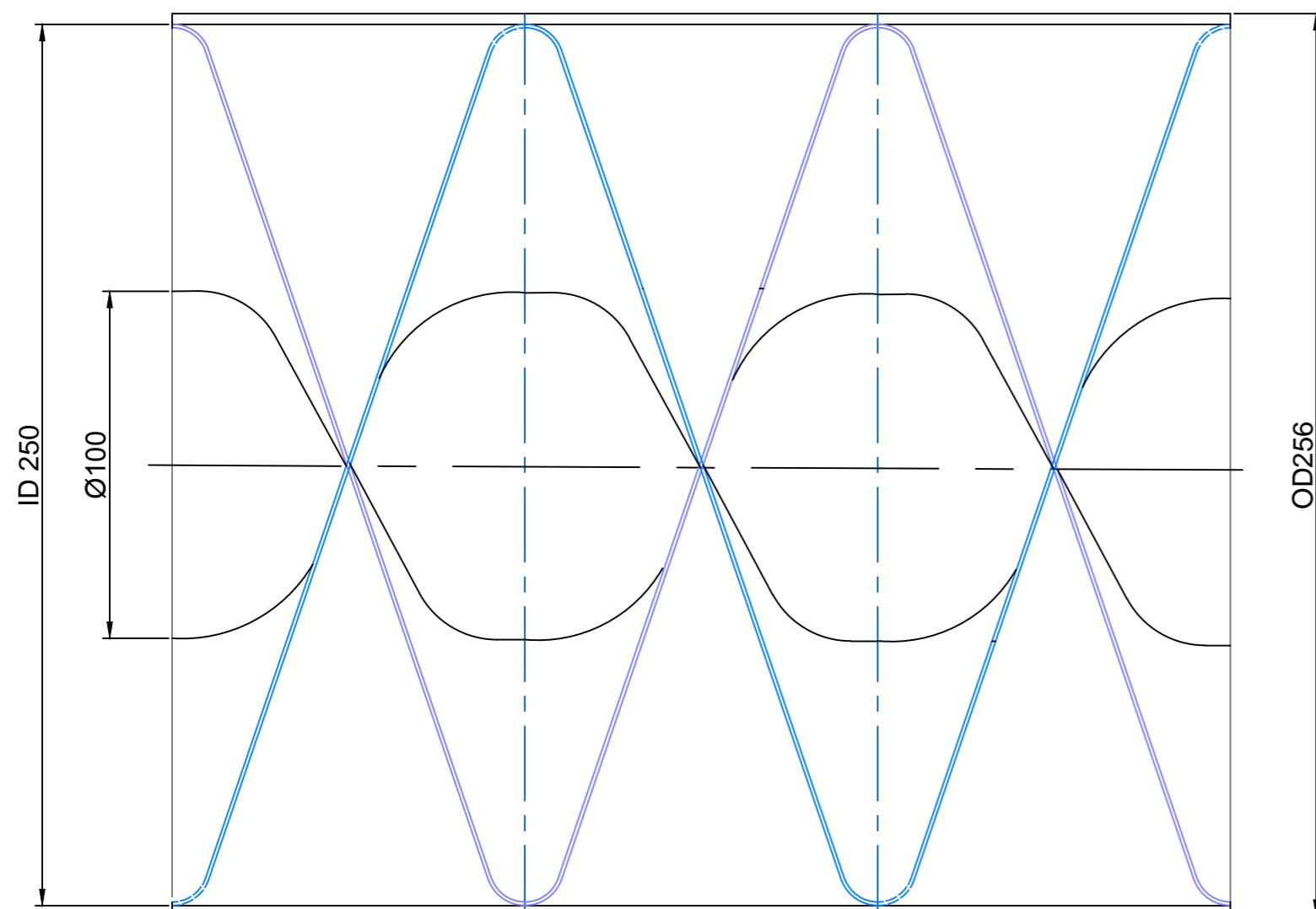

**PARTIAL ENLARGED VIEW**

Parallel key-EN8-55Hrc.

- 1) 16x10x 200 L-Qty.1no.
- 2) 10x6x 100 L-Qty-1no.

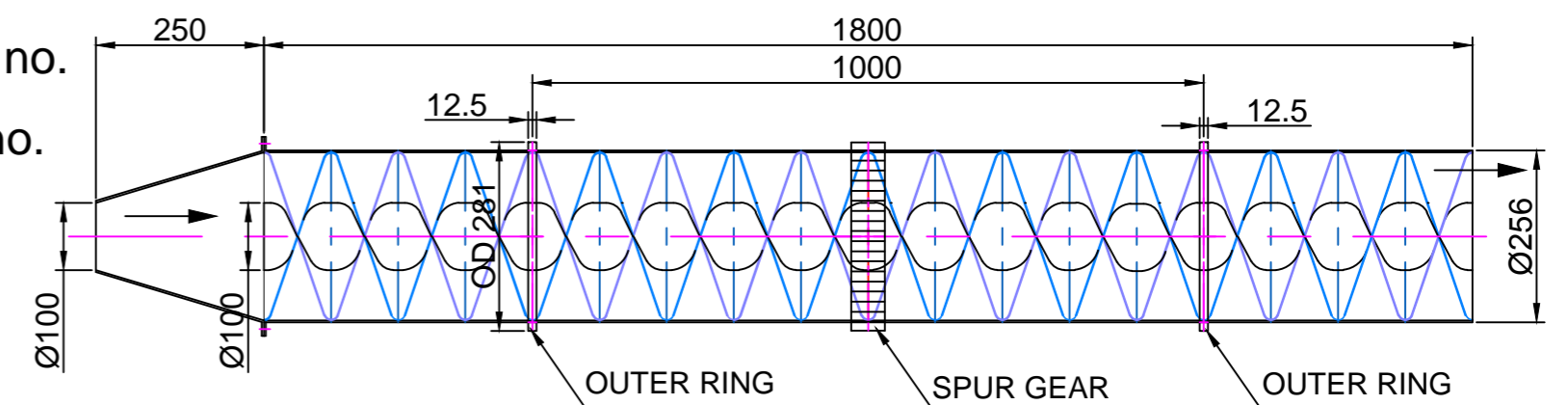

**ASSEMBLY OF SCREW CONVEYOR**

MATERIAL: AISI 316 L	<b>HLL LIFECARE LIMITED.</b> <b>Thiruvananthapuram-5</b>		NO:OFF.
DRAWN BY: PAUL M.P	TITLE:- SCREW CONVEYOR (LATEST)		
CHECKED BY:			
APPROVED BY:			
DATE: 05-12-2013	Drg.no:-HLL - CED - C2-010-02		
SCALE:	SHEET NO: 1 OF 1		
ALL DIMENSIONS ARE IN M.M	REV:-01 DATE:-08-05-2014		