

TENDER DOCUMENT

SUPPLY OF PRE HEATER AT IRAPURAM FACTORY, KOCHIN

**HLL LIFECARE LTD,
CENTRAL ENGINEERING DIVISION
PEROORKADA FACTORY,
THIRUVANANTHAPURAM – 695 005,
KERALA, INDIA.
PHN: ++91 471 2437270
FAX: ++91 471 2432647**

**IFB No.: HLL/CED/CON-AUG /PRE HEATER/BTADL CDM/IFC&KFB/2013
DATE : 21-12-2013**

HLL LIFECARE LIMITED

(A Government of India Enterprise)
Central Engineering Division, Peroorkada. P.O,
Thiruvananthapuram – 695005,
Kerala, India
Phn: 0471- 2437270, 2435090
Fax No. (0471) 2432647

INVITATION FOR BIDS (IFB)

IFB No : HLL/CED/CON-AUG/SUPPLY/PRE HEATER/BTADL CDM/IFC&KFB/2013
DATE : 21-12-2013

HLL Lifecare Limited (HLL) invites sealed and super scribed bids from competent and experienced eligible Suppliers/Contractors for the supply of following item in connection with the Augmentation of condom production at our factories in Kerala/Karnataka.

Sl. No	Brief Description of Item/Work	Quantity	EMD
1	Supply of Air Pre heater as per drawing and specifications at Irapuram Factory, Kerala	As per schedule of items	Rs.1500/-

I. INSTRUCTION TO BIDDERS:

1. A complete set of bid documents can be had from the Office of the Associate Vice President (CED), Central Engineering Division, HLL Lifecare Limited, Peroorkada Factory, Thiruvananthapuram – 695 005, Kerala, India during office hours on any working day on submission of written application.

The Tender Documents can also be downloaded from our Website www.lifecarehll.com and the Central Public Procurement Portal of Government of India www.eprocure.gov.in from the date of issue of tender document. Tender forms shall be filled in ink or typed. No tender filled in pencil shall be considered. The tenderer shall sign and seal the form at each page and at the end, in token of acceptance of all the terms and conditions of the tender. Any subsequent changes/amendments will be published only in our website & CPP portal.

2. The scheduled date for issue, receipt and opening of bids is as follows.

- a) Date of issue of tender document - 21-12-2013
- b) Last date and time for receipt of bids - 28-12-2013 up to 15.00 Hrs.
- c) Date and time of opening of bids - 28-12-2013 , 15.30 Hrs.

d) Address for communication, receipt and place of opening of bids:

Associate Vice President (CED)
Central Engineering Division,
HLL Lifecare Limited (A Government of India Enterprise),
PB No 2, Peroorkada, Thiruvananthapuram – 695005,
Kerala State, India
Ph: (++91 471) 2433374,2437270 –501,502
Tele Fax: (++ 91 471) 2432647
E-mail: srnair@lifecarehll.com, rajeevrv@lifecarehll.com

3. The Bid must include the following information;

- a. Enquiry No.
- b. Promised Delivery Schedule for each item.
- c. Acceptance Form (Schedule III)
- d. Price Schedule in Format For Quoting (Schedule IV)
- e. All other documents/certificate/information as specified in the bid document.

4. In addition to the invitation for bids, the bidding documents include the following schedules.

Schedule I	- Instruction to the Bidders
Schedule II	- Conditions of Contract
Schedule III	- Specifications
Schedule IV	- Acceptance Form
Schedule V	- Format for quoting

5. The completed and sealed bid documents should be submitted to Associate Vice President (CED), in the above address. The outer cover should bear the Enquiry No, closing date and General description of item tendered, and the words “DO NOT OPEN BEFORE” 15.30 Hrs (IST) on ----- (Indicate the Closing Date).

6. Bids will be opened in the presence of bidders’ representative(s) who choose to attend on the specified date and time, at the office of HLL at the address given in Clause 2 (d) above.

7. In the event of the date specified for bid receipt and opening being declared as a closed holiday for purchaser’s office, the due date for submission of bids and opening of bids will be the following working day at the appointed times.

8. The purchaser may, at its discretion, extend this deadline for submission of bids by amending the Bid Documents or any other reasons, in which case all rights and obligations of the Purchaser and Bidders previously subject to the deadline will thereafter be subject to the deadline as extended.

9. Purchaser will not be held responsible for the postal delay, if any, in the delivery of the bidding document or the non-receipt of the same. Bids sent by Telex/Fax/Telegraph will not be accepted.
10. HLL reserves the right to club or split the items of works, change the qualifying criteria at their discretion and to reject or cancel the Invitation for bids without assigning any reason thereof.

ASSOCIATE VICE PRESIDENT (CED)

SCHEDULE II

CONDITIONS OF CONTRACT

1) PRICE

The price quoted should be inclusive of Basic Price, all applicable taxes and duties including VAT, Entry tax, Octroi & other levies, P&F charges, loading and unloading charges, insurance, etc. The Supplier should pay entry taxes, as applicable and should be included in the offer.

The Format for Quoting (Schedule IV) shall be suitably filled as applicable. The quoted rate shall be valid for a period of 31st March 2014. No price escalation and no change in terms and conditions will be allowed on any ground till the order is completely executed.

2) TAXES/DUTIES/LEVIES

The supplier shall be entirely responsible for all taxes including entry tax, duties, license fees, etc. incurred until successful completion of contract. All central, state, municipal taxes, duties and levies payable shall be shown by the bidder separately in the Bid. The Purchaser will issue necessary 'C' Form, if required.

3) COMPLETION TIME

- a. The item should be delivered within 30 days from the date of issuing the Letter of Intent or Supply Order.
- b. The quantity mentioned herein are approximate requirement with staggered delivery.
- c. In case less or more quantity is required the suppliers should be prepared to effect supply at short notice on the same terms and conditions.

4) GUARANTEE PERIOD

The Guarantee against any possible manufacturing defects shall be given for a period of 18 months from the date of supply and inspection of the item at HLL site or 12 months from the date of supply, whichever is earlier. The supplier has to provide 10% performance bank guarantee valid for guarantee period as per tender.

5) LIQUIDATED DAMAGES FOR DELAYS

If the material is not supplied to the purchaser within the time stipulated in the Order, Purchaser may at their option, either (1) recover from the Supplier liquidated damages at the rate of 0.5 % of the total purchase order value for every week of delay, subject to a maximum of 7.5 % of the total purchase order value, or (2) at the risk and cost of the Supplier and without prejudice to the other remedies/rights as per the Contract, terminate the order wholly or partially and complete it themselves or reassign it to other Suppliers.

6) PAYMENT TERMS

90% of the total supply price will be paid against supply, inspection and acceptance of the items at HLL, Irapuram site, within 30 days. Balance 10% of the total supply price will be paid against Performance Bank Guarantee valid for 1 year from the date of acceptance of the item.

7. SETTLEMENT OF DISPUTES

Any disputes or differences or questions or claims arising under or relating to or touching this agreement shall be referred for arbitration to a Sole Arbitrator under the provisions of the Arbitration and Conciliation Act 1996 or any statutory modification or re-enactment thereof for the time be in force. The award passed by the arbitrator shall be final and binding on the parties hereto.

The contract shall be deemed to have been concluded at Thiruvananthapuram, Kerala and suits and proceedings, if any, shall be only in the courts of competent jurisdiction in Thiruvananthapuram.

The venue of arbitration shall be the place from where the contract is issued.

The company reserves the right to club or split the items of supply and reject or cancel the Invitation for bids without assigning any reason thereof.

SCHEDULE III
**DETAILED TECHNICAL SPECIFICATIONS FOR THE SUPPLY OF AIR PRE-
HEATER**

1. SUPPLY OF PRE- HEATER AS PER DRAWING NO.HLL-CED-C2—013-00 CAPABLE OF OBTAINING OF DRY CONDOMS AT THE RATE OF 170 TO 240 PCS PER MIN CONTINUOUSLY.
2. THE WORKS INVOLVED ARE INCLUSIVE OF SUITABLE DESIGN, INTEGRATION, AND SYNCHRONISATION OF THE SYSTEM. ALL ELECTRICAL AND ELECTRONIC COMPONENTS SHOULD AS PER INDIAN STANDARD.
3. INTAKE FILTER: THE INTAKE AIR SHOULD PASS THROUGH EU – 3 GRADE AIR TIGHT FILTER.
4. **DRIVE SYSTEM:** THE DRIVE SYSTEM OF THE BLOWER USED SHALL BE OF POWER – 1HP, CAPACITY – 100 CMH, SPEED- 2900 RPM, MATERIAL SCROLL HOUSING – DIE CAST ALUMINUM, IMPELLER – GALVANIZED SHEET AND STRUCTURE – INDUSTRIAL STANDARD.
5. **ELECTRICAL HEATER:** THE HETAER SHOULD BE OF FINE TYPE OF 1000 WATTS EACH. THE APPROXIMATE QUANTITY IS 6 NOS. THE TOTAL WATTAGE WILL BE ABOUT 6KW.THE REQUIRED PROCESS TEMPERATURE WOULD BE 100 DEG C. THE HEATER CONTROLLER FOR 6KW IS THYRISTOR HEATER DRIVE.
6. **ELECTRICAL REQUIREMENT:** THE SIZE OF THE PANEL WILL BE APPROXIMATE 2 X 3 FEET. HETAER DRIVE IS THYRISTOR. THE TEMPERATURE CONTROLLER WITH RTD SENSOR SHOULD BE OF REPUTED MAKE. THE ISOLATOR, MCB, ON/OFF SWITCHES MAIN PANEL BORD TEMPERATURE CONTROLLER, BLOWER MOTOR PROTECTION SWITCH GEARS CIRCUIT ARE FULLY WIRED AND TERMINATED AT THE BOTTOM
7. **SAFETY REQUIREMNT:** NOISE LEVEL SHOULD BE 75 DB WHILE IN OPERATION.
8. **ENGINEERING REQUIREMENT:**
 - DESIGN OF EQUIPMENT SHOULD ENHANCE BY PROVIDING NO SHARP CORNERS, MINIMUM CREVICES & SMOOTH FINISHED WELD JOINTS.

- GASKETS, SEALS & O –RINGS COMING IN DIRECT/INDIRECT CONTACT SURFACES SHOULD BE CONSTRUCTED OF WHO APPROVED FOOD GRADE MATERIALS ONLY.
 - ALL MATERIAL SHOULD HAVE TEST CERTIFICATE.
 - EQUIPMENT SHOULD BE FABRICATED BY FOLLOWING ALL GOOD ENGINEERING PRACTICES.
 - SYSTEM SHALL BE INSPECTED & TESTED AT VENDORS SITE.
9. THE MATERIAL USED IN THE PATHS AND CONTACT PARTS SHOULD BE PERFECTLY IN CONFORMANCE TO ELIMINATE HANDLING DAMAGE TO THE NATURAL RUBBER PRODUCT AND AS PER WHO GMP STANDARDS.
 10. ALL CONTROLLERS SHOULD BE SUITABLE FOR WITHSTANDING POWER FLUCTUATIONS AND WITH SOFT STARTING TECHNOLOGY. SUITABLE PANEL BOARD SHOULD BE PROVIDED AT REMOTE AREA COMPLYING ALL SAFETY NORMS.
 11. NECESSARY PAINTING WORKS SUITABLE FOR DUSTY AND HOT ENVIRONMENT AS PER STANDARD NORMS.
 12. STATIC ELECTRICITY DISCHARGERS SHOULD BE PROVIDED WHEREVER NECESSARY.
 13. RATE SHOULD BE QUOTED SEPARATELY FOR SUPPLY AND SERVICE LIKE INTEGRATION, TESTING AND COMMISSIONING OF ONE SUCH SYSTEM AS PER PRICE SCHEDULE .BILL OF MATERIALS SHOULD BE PROVIDED SEPARATELY IN SUPPORT TO THE SUPPLY.
 14. COMMISSIONING: COMMISSIONING OF THE SYSTEM OR ANY PART THEREOF SHALL BE COMMENCED BY THE BIDDER IMMEDIATELY AFTER RECEIPT OF INTIMATION FROM HLL. HLL SHALL SUPPLY THE OPERATING PERSONNEL AND ALL RAW MATERIALS, UTILITIES, LUBRICANTS, CHEMICALS SERVICES AND OTHER MATTERS REQUIRED FOR COMMISSIONING.
 15. **PERFORMANCE TEST:** THE PERFORMANCE TEST SHALL BE CONDUCTED BY THE BIDDER DURING THE COMMISSIONING OF THE SYSTEM TO

ASCERTAIN WHETHER THE SYSTEM CAN ATTAIN THE FUNCTIONAL GUARANTEES SPECIFIED IN THE TECHNICAL SPECIFICATION.

16. **OPERATIONAL ACCEPTANCE:** OPERATIONAL ACCEPTANCE SHALL OCCUR IN RESPECT OF THE SYSTEM WHEN THE PERFORMANCE TEST HAS BEEN SUCCESSFULLY COMPLETED AND THE FUNCTIONAL PERFORMANCES ARE MET.
17. PERIOD WARRANTY SHALL BE 12 MONTHS FROM THE DATE OF INSTALLATION AND COMMISSIONING AS CERTIFIED JOINTLY BY THE SUPPLIER AND THE PURCHASER.
18. THE BIDDER SHALL ATTEND THE PRE-BID CONFERENCE ARRANGED BY HLL BEFORE SUBMITTING THE OFFER.
19. THREE COPIES OF INSTRUCTION/OPERATIONAL MANUAL (ESPECIALLY FOR BROUGHT OUT ITEMS) AND MAINTENANCE MANUAL SHOULD BE SUPPLIED ALONG WITH THE MACHINE.
20. A LIST OF SPARE PARTS SHOULD BE PROVIDED. A MINIMUM SET OF SPARE PARTS SHOULD BE PROVIDED FOR EACH MACHINE.
21. BROUGHT OUT ITEMS SUCH AS ELECTRICAL/ELECTRONIC ITEMS, ELECTRIC HEAT BANKS ETC SHOULD BE AS PER RELEVANT INDIAN STANDARDS APPROVED CERTIFICATIONS.

Schedule IV

ACCEPTANCE FORM

(To be submitted in the letter pad of the firm indicating full name and address, telephone & fax numbers etc.)

From

To

Associate Vice President (CED)
Central Engineering Division,
HLL Lifecare Limited (A Government of India Enterprise),
PB No 2, Peroorkada, Thiruvananthapuram – 695005,
Kerala State, India
Ph: (++91 471) 2433374,2437270 –501,502
Tele Fax: (++ 91 471) 2432647
E-mail: srnair@lifecarehll.com, rajeevrv@lifecarehll.com

Dear Sir,

I / We, hereby offer to supply materials as detailed in schedule here to or such portion thereof as you may specify in the acceptance of Bid at the price given in the price bid and agree to hold this offer open till 90 days after the date of bid opening prescribed by the purchaser. I/We have understood the terms and conditions mentioned in the invitation for bid and Conditions of Contract furnished by you and have thoroughly examined the specifications and drawings in the bid document hereto and are fully aware of the nature of the scope of supply and my/our offer is to comply strictly in accordance with the requirement and the terms and conditions mentioned above. I/We have understood that the PURCHASER is the sole owner of the technology, equipment, specification and drawings given along with the bidding documents. I/we here by assure that the above information will be kept confidential and will not be used for any other purpose or will not be transferred to third party.

Yours faithfully,

SIGNATURE OF THE BIDDER

**SCHEDULE V
FORMAT FOR QUOTING**

**SCHEDULE FOR THE SUPPLY OF AIR PRE HEATER AT IRPURAM FACTORY,
KOCHIN**

Sl.No.	Description of Item	Unit	Quantity	Rate in Rs.	Amount in Rs.
1	Supply of Air pre heater as per drawing no. HLL-CED-B2-013-00 at our Irapuram Factory,Kochin	NOS.	4.00		
	Basic price in Rs.				
	Packing & Forwarding charges Rs.				
	CST in Rs.				
	Freight charges in Rs.				
	Other taxes/Charges any in Rs.				
	Gross Amount in Rs.				

(In words)

I agree to supply all the items as per schedule at the rates quoted by me as above and the terms and conditions of the tender document.

SIGNATURE OF THE SUPPLIER

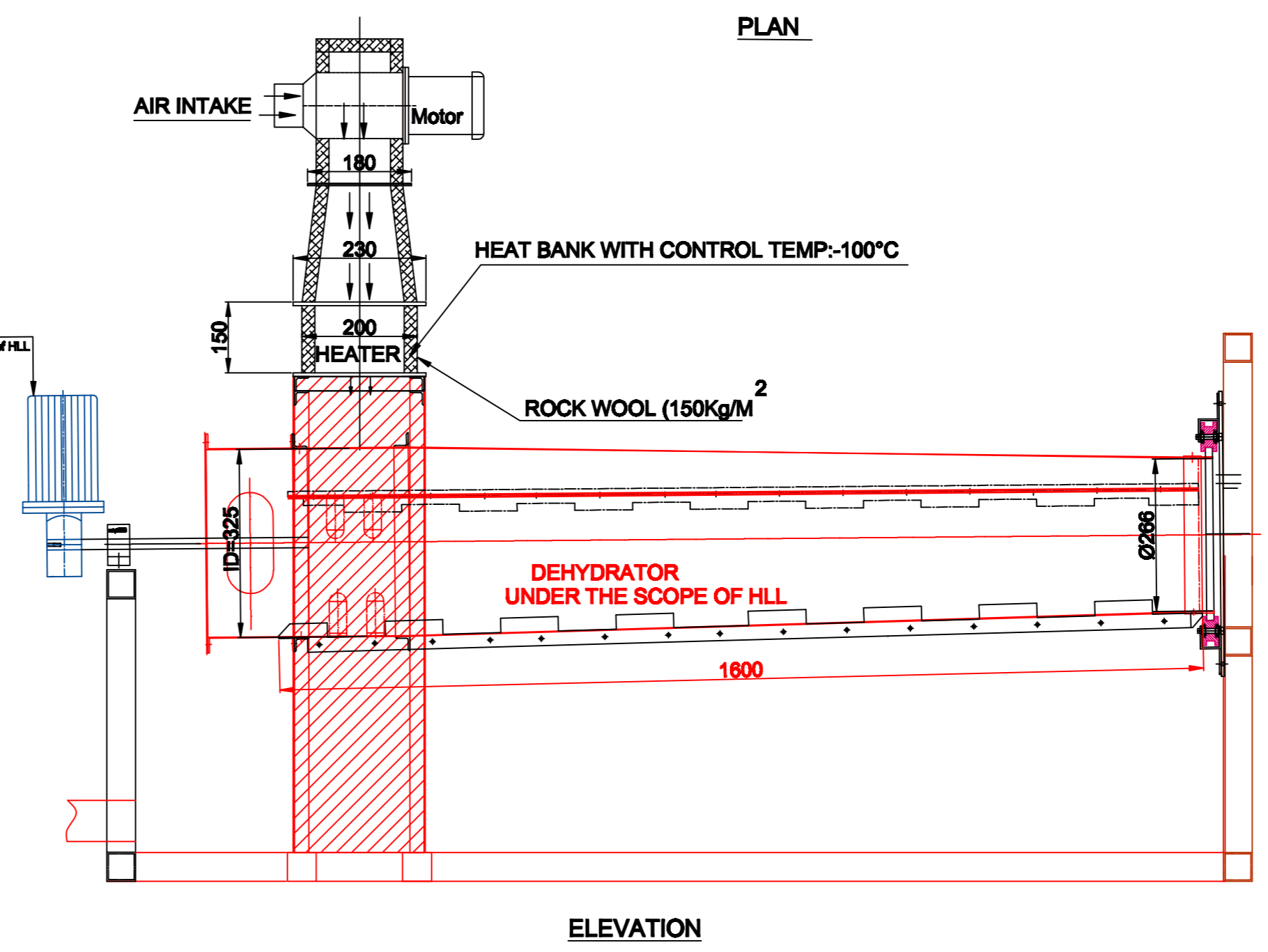
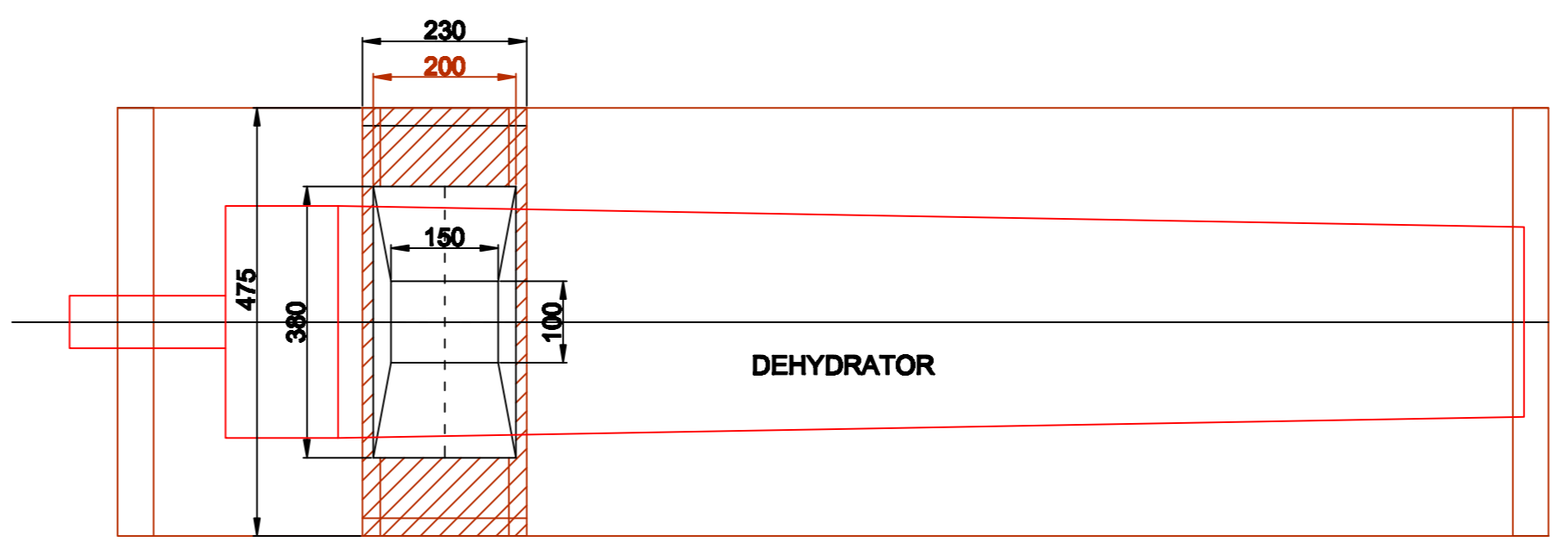
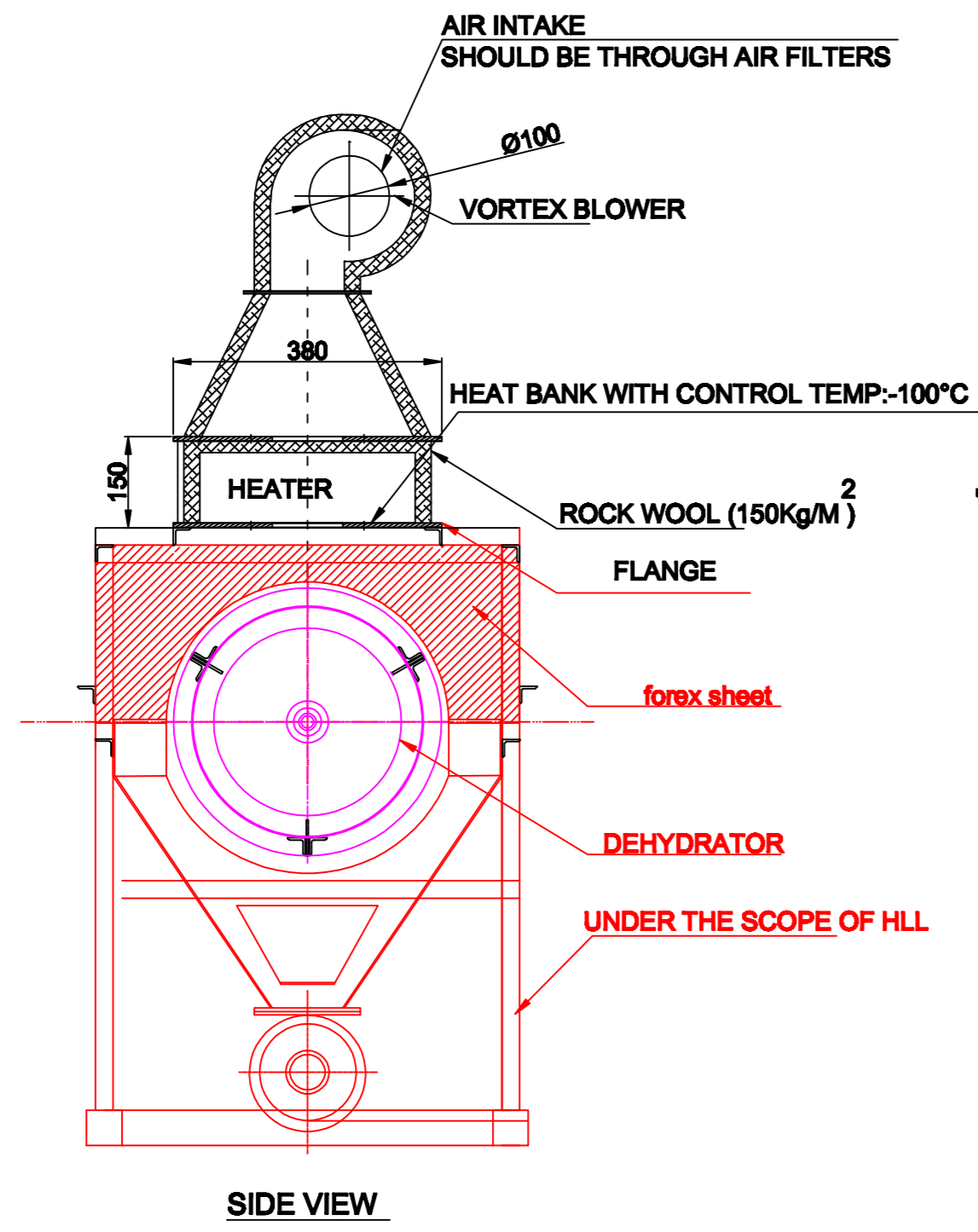

SIDE VIEW

PLAN

ELEVATION

SPECIFICATION		
VORTEX BLOWER	HEATER	INSULATION
POWER 1HP	FIN TYPE ,1000 WATTS	ROCK WOOL (150Kg/M ²)
CAPACITY 100 CMH	QTY ; 6 NOS	AS PER THE REQUIREMENT
SPEED 2900 RPM		
IMPELLOR :- GALVANIZED SHEET		
MATERIAL : SCROLL HOUSING-DIE CAST ALUMINIUM		
TYPE OF PROTECTION : IP44 FILTER -EU -3 GRADE LEAK TIGHT		
NOTE:- PARTY HAS TO ASSURE TO ACHIVE EFFECTIVE DRYING OF CONDOMS AFTER ASSEMBLING. REPUTED MAKE SHALL BE USED FOR THE ALL ITEMS.		

MATERIAL:		HLL Lifecare Limited.		NO:OFF.
		Thiruvananthapuram-5		
DRAWN BY:	M.P.PAUL	TITLE:- AIR PRE - HEATER		
CHECKED BY:				
APPROVED BY:				
DATE:	04-01-2012	HLL-CED-C2- 013-00		
SCALE:				
ALL DIMENSIONS ARE IN M.M		SHEET.NO:-1OFF.1		REV:- DATE:-