

एचएलएल लाइफ़केयर लिमिटेड /HLL LIFECARE LIMITED

(भारत सरकार का उघम) / (A GOVT.OF INDIA ENTERPRISE)

आक्कुलम फैक्टरी , श्रीकार्यम पी .ओ / AKKULAM FACTORY,SREEKARIYAM P.O.

तिरुवन्नतपुरम -695 017 / THIRUVANANTHAPURAM-695 017

फोन नं : 0471 2442642 फाक्स नं : 0471 2441383 / PHONE NO:0471 2442642; FAX NO:0471 2441383;

EMAIL: materialsft@lifecarehll.com

TENDER NO. HLL/AFT/MTLS/BB/TITAN/NC-RC /2018-21

Dated 05/12/2018



ITEM: NEEDLE COVER (PVC) WITH OUTER PP COVER

Tender No: HLL/AFT/MTLS/BB/TITAN/NC-RC/2018-21

TECHNO-COMMERCIAL BID

एचएलएल लाइफ़केयर लिमिटेड /HLL LIFECARE LIMITED

(भारत सरकार का उद्यम) / (A GOVT.OF INDIA ENTERPRISE)

आक्कुलम फैक्टरी , श्रीकार्यम पी .ओ / AKKULAM FACTORY,SREEKARIYAM P.O.

तिरुवन्नतपुरम -695 017 / THIRUVANANTHAPURAM-695 017

फोन नं : 0471 2442642 फाक्स नं : 0471 2441383 / PHONE NO:0471 2442642; FAX NO:0471 2441383;

EMAIL: materialsft@lifecarehll.com

TENDER NO. HLL/AFT/MTLS/BB/TITAN/NC-RC /2018-21

Dated 05/12/2018

निविदा सूचना

TENDER NOTICE

वर्ष २०१८-२१ के लिए हमारी आक्कुलम फैक्टरी तिरुवनन्तपुरम , **नीडिल कवर (पीवीसी) बाहरी पीपी कवर के साथ** विनिर्माण /प्राधिकृत एजन्टों से भारत में विनिर्मित उत्पादों के लिए निर्धारितप्रपत्र में दो बोली प्रणाली (तकनीकी / वाणिज्य) के अधीन मुहरबंदित और उपरिलिखित निविदाएँ आमंत्रित किया जाता है

Sealed and superscribed tenders under Two Bid System (Techno-Commercial) in the prescribed form are invited for products manufactured in India from Manufacturer(s)/Authorised agents for the supply of **Needle cover (PVC) with Outer PP Cover** to our Akkulam Factory for the year 2018-21.

तकनीकी विनिर्देश, अनुमानित मात्राएं और अन्य निबंधन एवं शर्तें निविदा दस्तावेजों में दिये जाते हैं, जो प्रत्येक निविदा के लिए एचएलएल लाइफ़केयर के नाम पर तिरुवनन्तपुरम में देय रुपए 1050.00 का डीडी देकर 06/12/2018 से पूर्वाह्न 10.30 बजे से अपराह्न 3.30 बजे तक हमारे कार्यालय के किसी भी कार्य दिवस पर प्राप्त किया जा सकता है। डी डी एचएलएल लाइफ़केयर के नाम पर तिरुवनन्तपुरम में देय किसी राष्ट्रीयकृत बैंक का होना चाहिए।

The technical specification, approximate quantities and other terms and conditions are given in the Tender documents, which can be had from our office on any working day from 06/12/2018 between 10.30 A.M to 3.30 P.M by paying INR.1050.00 DD (inclusive of GST) for each tender in favour of HLL Lifecare Limited, Akkulam payable at Trivandrum.

एचएलएल लाइफकेयर लिमिटेड /HLL LIFECARE LIMITED

(भारत सरकार का उद्यम) / (A GOVT.OF INDIA ENTERPRISE)

आक्कुलम फैक्टरी , श्रीकार्यम पी .ओ / AKKULAM FACTORY,SREEKARIYAM P.O.

तिरुवन्नतपुरम -695 017 / THIRUVANANTHAPURAM-695 017

फोन नं : 0471 2442642 फाक्स नं : 0471 2441383 / PHONE NO:0471 2442642; FAX NO:0471 2441383;

EMAIL: materialsft@lifecarehll.com

TENDER NO. HLL/AFT/MTLS/BB/TITAN/NC-RC /2018-21

Dated 05/12/2018

विवरण हमारे वेबसाइट www.lifecarehll.com से भी मिल सकता है । निविदाकार हमारे वेबसाइट से दस्तावेज़ डाउनलोड किया जा सकता है और ऐसी स्थिति में निविदा शुल्क, तकनीकी बोली के साथ डीडी द्वारा अदा किया जाना चाहिए।

The details can also be had from our Website at www.lifecarehll.com. The tenderers can download the documents from our website and in such case the tender fee should be paid by way of DD along with technical bid.

तकनो-वाणिज्य बोली दस्तावेजों को जारी करने की अंतिम तारीख एवं समय 27.12.2018 मध्याह्न 1.00 बजे तक होगा। संपूर्ण निविदाएं एचएलएल लाइफकेयर में निविदा संख्या उपरिलिखित मुहरबंदित लिफाफे में 27.12.2018, 1.00 बजे तक मिलना चाहिए।

The last date & time of issue of Techno-commercial Bid documents will be up to 27.12.2018; 1.00 P.M. Completed tenders in sealed cover superscribed with Tender Nos. should reach latest by 27.12.2018; 1.00 pm

संक्रमण में हुई किसी विलम्ब के लिए एचएलएल लाइफकेयर लिमिटेड उत्तरदायी नहीं होगा।

HLL will not be responsible for any delay in transit.

तकनीकी बोली में योग्यताप्राप्त निविदाकारों की मूल्यबोली मात्र खोली जाएगी।

The Price Bid of those Tenderers who qualify in the Technical Bid only will be opened.

एचएलएल लाइफ़केयर लिमिटेड /HLL LIFECARE LIMITED

(भारत सरकार का उद्यम) / (A GOVT.OF INDIA ENTERPRISE)

आक्कुलम फैक्टरी , श्रीकार्यम पी .ओ / AKKULAM FACTORY,SREEKARIYAM P.O.

तिरुवन्नतपुरम -695 017 / THIRUVANANTHAPURAM-695 017

फोन नं : 0471 2442642 फाक्स नं : 0471 2441383 / PHONE NO:0471 2442642; FAX NO:0471 2441383;

EMAIL: materialsft@lifecarehll.com

TENDER NO. HLL/AFT/MTLS/BB/TITAN/NC-RC /2018-21

Dated 05/12/2018

मूल्य बोली खोलने की तारीख एवं समय अलग रूप से सूचित किया जाएगा। तकनीकी बोली मूल्यांकन में अयोग्यताप्राप्त निविदाकारों की मूल्यबोली बिना खोले वापस की जाएगी।

The date and time of opening of Price bid will be intimated separately. The Price Bids of Tenderers who do not qualify in the Technical bid evaluation will be returned unopened.

महाप्रबंधक (सामग्री) / GENERAL MANAGER (MATERIALS)

HLL/AFT/MTLS/BB/TITAN/NC-RC/2018-21

एचएलएल लाइफकेयर लिमिटेड /HLL LIFECARE LIMITED

(भारत सरकार का उद्यम) / (A GOVT.OF INDIA ENTERPRISE)

आक्कुलम फैक्टरी , श्रीकार्यम पी .ओ / AKKULAM FACTORY,SREEKARIYAM P.O.

तिरुवन्नतपुरम -695 017 / THIRUVANANTHAPURAM-695 017

फोन नं : 0471 2442642 फाक्स नं : 0471 2441383 / PHONE NO:0471 2442642; FAX NO:0471 2441383;

EMAIL: materialsft@lifecarehll.com

TENDER NO. HLL/AFT/MTLS/BB/TITAN/NC-RC /2018-21

Dated 05/12/2018

Dear Sirs,

Sub: Tender Forms for Technical Bid & Price Bid

We are enclosing herewith the Techno-Commercial Bid & Price Bid Tender Forms.

The Tender Forms are to be duly filled up in duplicate, signed and returned, in a sealed cover superscribed with the above Tender No., the due date and date of opening, addressed to the GENERAL MANAGER (MATERIALS), HLL LIFE CARE LIMITED, AKKULAM FACTORY, SREEKARIYAM P.O., THIRUVANANTHAPURAM-695017.

The last date & time of receipt of Bids : 27.12.2018; 1.00 P.M

Date & Time of opening of Technical Bid : 27.12.2018; 2.30 P.M

The details can also be had from our Website at www.lifecarehll.com.

Incomplete tender is likely to be rejected without any further correspondence.

Yours faithfully,
For HLL LIFE CARE LIMITED.

GENERAL MANAGER (MATERIALS)

Encl: As above

एचएलएल लाइफ़केयर लिमिटेड /HLL LIFECARE LIMITED

(भारत सरकार का उद्यम) / (A GOVT.OF INDIA ENTERPRISE)

आक्कुलम फैक्टरी , श्रीकार्यम पी .ओ / AKKULAM FACTORY,SREEKARIYAM P.O.

तिरुवन्नतपुरम -695 017 / THIRUVANANTHAPURAM-695 017

फोन नं : 0471 2442642 फाक्स नं : 0471 2441383 / PHONE NO:0471 2442642; FAX NO:0471 2441383;

EMAIL: materialsft@lifecarehll.com

TENDER NO. HLL/AFT/MTLS/BB/TITAN/NC-RC /2018-21

Dated 05/12/2018

CONTENTS OF BID DOCUMENT

I. INSTRUCTION TO BIDDERS:

II. TECHNICAL BID FORMS

1. Schedule A - Drawing, Specification & Quantity
2. Schedule B - Questionnaire for minimum eligibility criteria
3. Schedule C - Questionnaire - General information of the Manufacturer / Supplier
4. Schedule D - Questionnaire -Quality testing information of the Manufacturer / Supplier
5. Schedule E - Terms & conditions
6. Schedule F - Questionnaire for Vendor Development
7. Schedule G - Declaration accepting Terms and Conditions of the Tender

III. PRICE BID

एचएलएल लाइफकेयर लिमिटेड /HLL LIFECARE LIMITED

(भारत सरकार का उद्यम) / (A GOVT.OF INDIA ENTERPRISE)

आक्कुलम फैक्टरी , श्रीकार्यम पी .ओ / AKKULAM FACTORY,SREEKARIYAM P.O.

तिरुवन्नतपुरम -695 017 / THIRUVANANTHAPURAM-695 017

फोन नं : 0471 2442642 फाक्स नं : 0471 2441383 / PHONE NO:0471 2442642; FAX NO:0471 2441383;

EMAIL: materialsft@lifecarehll.com

TENDER NO. HLL/AFT/MTLS/BB/TITAN/NC-RC /2018-21

Dated 05/12/2018

Page 1of 2

INSTRUCTIONS TO BIDDERS

- a) The Bid is intended to procure material as per specification in Schedule A
- b) The Bid consist of two parts:
a. Technical Bid
b. Price Bid
- c) The Technical Bid should be accompanied by Earnest Money Deposit (EMD) in the form of DD drawn in favour of M/s. HLL Lifecare Limited payable at Trivandrum for a sum of Rs. 85,000.00/- failing which the Tender is likely to be summarily rejected. The EMD submitted will be converted to Security Deposit and will be released at the end of contract period. **SSI/MSME** units interested in availing exemption from payment of Tender Fee & EMD should submit a valid copy of their **registration certificate and Udyog Aadhar** issued by the concerned DIC or NSIC. But the Party has to provide Security deposit if Tender is awarded to them.
- d) Technical & Price Bids should be in separate sealed covers. Technical and Price **Bids shall be superscribed as "Technical Bid" and "Price Bid"** on the respective covers in order to clearly identify between the two Bids. These two bids should be submitted in a single sealed cover with the respective Tender No. mentioned thereon, complete in all respect, addressed to the General Manager (Materials) HLL Lifecare Limited , Akkulam Factory, Sreekariyam P.O., Trivandrum – 695 017, on or before the due date and time mentioned in the Tender Notification. HLL shall not be responsible for any delay, if any, in the delivery of the bidding document or non-receipt of the same.
- e) The validity of technical and price bid for three years (2018-21).
- f) **Bid submission / Bid opening dates**
The last date & time of receipt of Bids : 27.12.2018; 1.00 PM
Date & Time of opening of Technical Bid : 27.12.2018; 2.30 PM
- g) In the event of the date mentioned above being declared subsequently as holiday for the purchaser's office, the due date for submission and opening of bids will be the next working day at the same venue and time.

एचएलएल लाइफ़केयर लिमिटेड /HLL LIFECARE LIMITED

(भारत सरकार का उद्यम) / (A GOVT.OF INDIA ENTERPRISE)

आक्कुलम फैक्टरी , श्रीकार्यम पी .ओ / AKKULAM FACTORY,SREEKARIYAM P.O.

तिरुवन्नतपुरम -695 017 / THIRUVANANTHAPURAM-695 017

फोन नं : 0471 2442642 फाक्स नं : 0471 2441383 / PHONE NO:0471 2442642; FAX NO:0471 2441383;

EMAIL: materialsft@lifecarehll.com

TENDER NO. HLL/AFT/MTLS/BB/TITAN/NC-RC /2018-21

Dated 05/12/2018

Page 2 of 2

INSTRUCTIONS TO BIDDERS

- h) Bids received after the deadline for submission shall not be considered.
- i) The Bidder is expected to examine all specifications, Instructions, Forms, Terms and conditions given in the Bidding documents. Failure to furnish all information required in the Bidding documents or submission of a Bid not substantially responsive to the bidding documents in every respect will be at the Bidders risk and may result in rejection of the Bid
- j) Any clarification required will have to be obtained one week prior to the Date of opening of the Technical Bid.
- k) A certificate/Declaration as given in Schedule G stating that ALL TERMS AND CONDITIONS of this Tender is acceptable should accompany the tender failing which the tender is likely to be summarily rejected.
- l) The quantity mentioned herein are approximate annual requirement with staggered delivery and in case less or more quantity is required the suppliers should be prepared to effect supply at short notice on the same terms and conditions.
- m) **(i) The Price Bid of those Tenderers who qualify in the Technical Bid only will be opened. The date and time of opening of price bid will be intimated separately.**
- (ii) The Price Bids of Tenderers who do not qualify will be returned unopened.**

.....

एचएलएल लाइफकेयर लिमिटेड / HLL LIFECARE LIMITED

(भारत सरकार का उद्यम) / (A GOVT.OF INDIA ENTERPRISE)

आक्कुलम फैक्टरी , श्रीकार्यम पी .ओ / AKKULAM FACTORY,SREEKARIYAM P.O.

तिरुवन्नतपुरम -695 017 / THIRUVANANTHAPURAM-695 017

फोन नं : 0471 2442642 फाक्स नं : 0471 2441383 / PHONE NO:0471 2442642; FAX NO:0471 2441383;

EMAIL: materialsft@lifecarehll.com

TENDER NO. HLL/AFT/MTLS/BB/TITAN/NC-RC /2018-21

Dated 05/12/2018

SCHEDULE- A
Page 1 of 9

DRAWING AND TECHNICAL SPECIFICATIONS FOR THE SUPPLY OF “NEEDLE COVER (PVC) WITH OUTER PP COVER”.

(a) Soft PVC Needle Cover

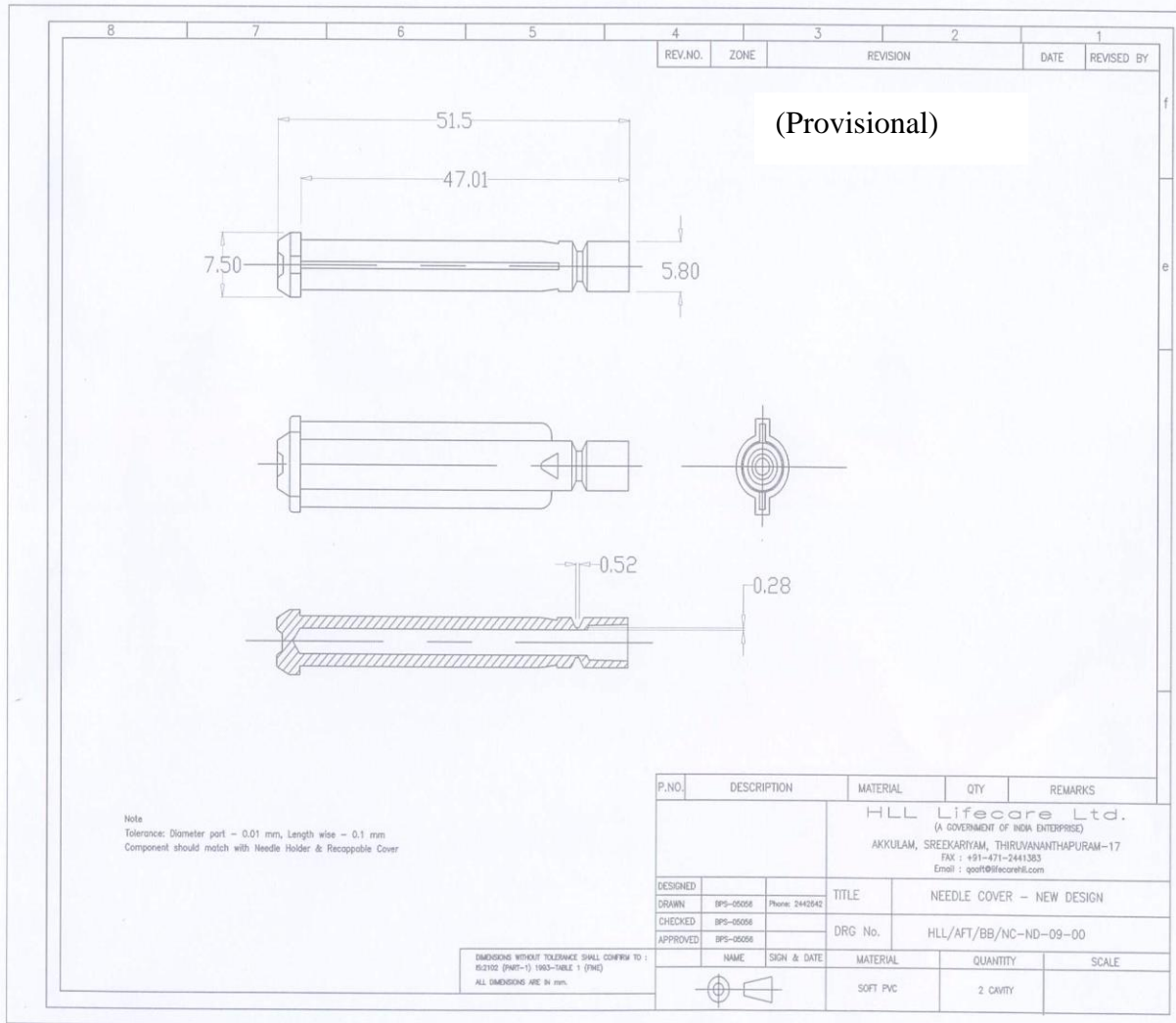

एचएलएल लाइफ़केयर लिमिटेड /HLL LIFECARE LIMITED

(भारत सरकार का उद्यम) / (A GOVT.OF INDIA ENTERPRISE)

आक्कुलम फैक्टरी , श्रीकार्यम पी .ओ / AKKULAM FACTORY,SREEKARIYAM P.O.

तिरुवन्नतपुरम -695 017 / THIRUVANANTHAPURAM-695 017

फोन नं : 0471 2442642 फाक्स नं : 0471 2441383 / PHONE NO:0471 2442642; FAX NO:0471 2441383;

EMAIL: materialsft@lifecarehll.com

TENDER NO. HLL/AFT/MTLS/BB/TITAN/NC-RC /2018-21

Dated 05/12/2018

SCHEDULE- A

Page 2 of 9

SPECIFICATION

1. Design: As per drawing No.: HLL/AFT/NC-ND-09-00
2. Material of the component: Medical Grade Soft PVC, Moulding Grade, Shore A-Hardness - 72 to 78
3. Major Dimensions: Refer Drawing No HLL/AFT/NC-ND-09-00
4. Allowable parting line limit: 30 micron
5. Allowable gate projection: 50 micron
6. Allowable Ovality: 30 micron
7. Dimensional and Visual Inspection: Component must be free from dimensional variations (critical dimensions- pinch off portion dimensions, holder fitment portion, length of component), flash, bend, embedded dust, black spot, colour change, silver streaks, ovality, deformation at gate point, etc.
8. Assembling suitability: The needle cover must be perfectly suitable to assemble with Needle Holder (component sample will be provided by HLL for reference purpose) and Re-cappable cover (fitment & locking properties).
9. Sterilization / Autoclaving requirement: Components must be stable for autoclaving and it should not crack or bend on autoclaving.
10. Maximum allowable shrinkage on autoclaving: Less than 8%

Note: Soft PVC Medical Grade Raw Material Procurement: Material must be procured from HLL approved suppliers / Vendors as per HLL specification / formulation.

HLL/AFT/M

एचएलएल लाइफकेयर लिमिटेड / HLL LIFECARE LIMITED

(भारत सरकार का उद्यम) / (A GOVT.OF INDIA ENTERPRISE)

आक्कुलम फैक्टरी , श्रीकार्यम पी .ओ / AKKULAM FACTORY,SREEKARIYAM P.O.

तिरुवन्नतपुरम -695 017 / THIRUVANANTHAPURAM-695 017

फोन नं : 0471 2442642 फाक्स नं : 0471 2441383 / PHONE NO:0471 2442642; FAX NO:0471 2441383;

EMAIL: materialsft@lifecarehll.com

TENDER NO. HLL/AFT/MTLS/BB/TITAN/NC-RC /2018-21

Dated 05/12/2018

SCHEDULE- A
Page 3 of 9

(b) Re - Capable Outer Polypropylene Cover

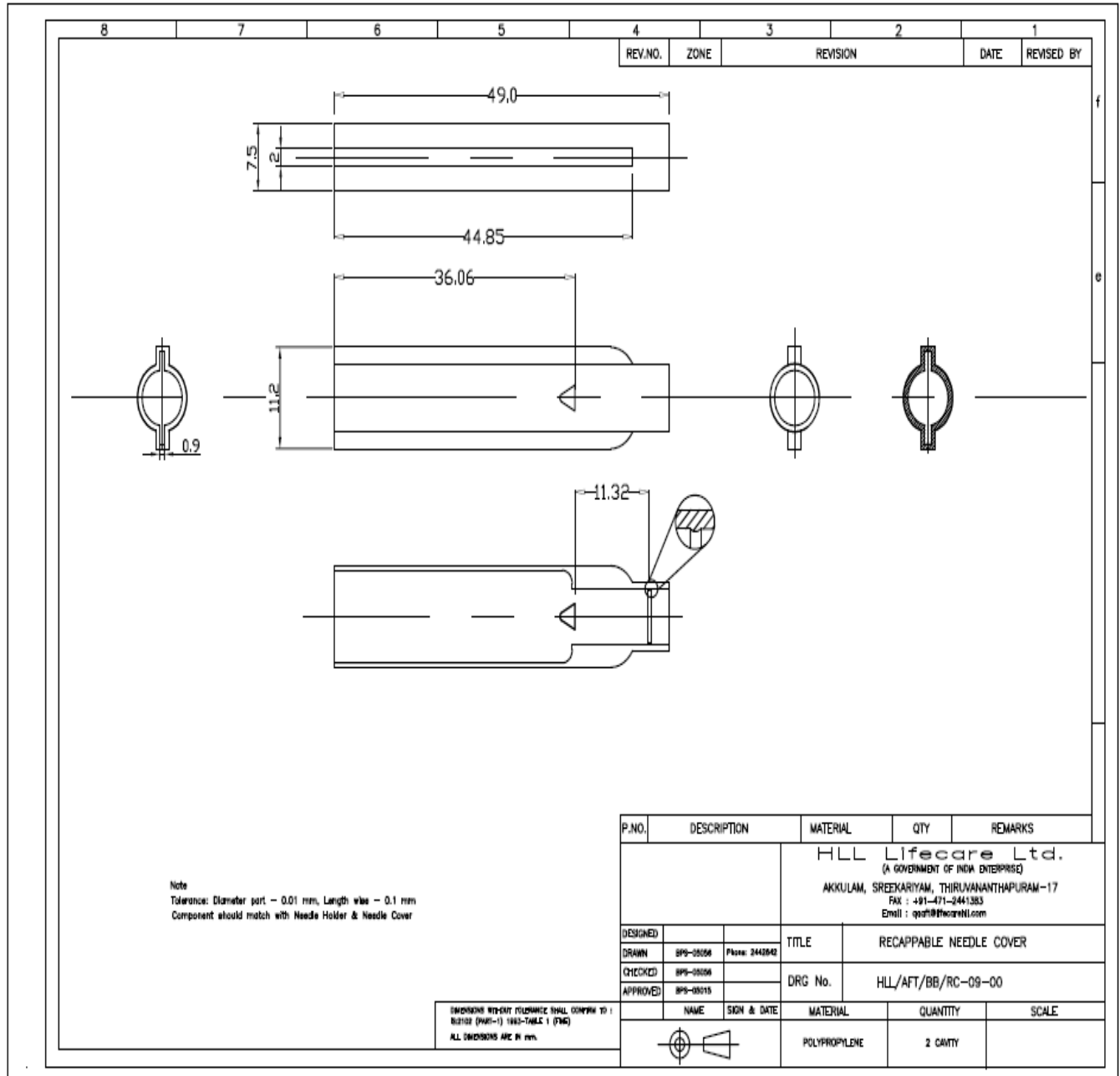

एचएलएल लाइफ़केयर लिमिटेड /HLL LIFECARE LIMITED

(भारत सरकार का उद्यम) / (A GOVT.OF INDIA ENTERPRISE)

आक्कुलम फैक्टरी , श्रीकार्यम पी .ओ / AKKULAM FACTORY,SREEKARIYAM P.O.

तिरुवन्नतपुरम -695 017 / THIRUVANANTHAPURAM-695 017

फोन नं : 0471 2442642 फाक्स नं : 0471 2441383 / PHONE NO:0471 2442642; FAX NO:0471 2441383;

EMAIL: materialsft@lifecarehll.com

TENDER NO. HLL/AFT/MTLS/BB/TITAN/NC-RC /2018-21

Dated 05/12/2018

SCHEDULE- A

Page 4 of 9

SPECIFICATION

1. Design: As per drawing No.: HLL/AFT/BB/RC-09-00
2. Material of the component: Polypropylene (Grade-Reliance REPOL H110MA / REPOL H200MK)
3. Major Dimensions: Refer Drawing No HLL/AFT/BB/RC-09-00
4. Allowable parting line limit: 50 micron
5. Allowable gate projection: 50 micron
6. Allowable Ovality: 30 micron
7. Dimensional and Visual Inspection: Component must be free from flash, bend, embedded dust, black spot, colour change, silver streaks, ovality, deformation at gate point, etc.
8. Assembling suitability: The Re-cappable cover must be perfectly suitable to assemble with Needle Holder (component sample will be provided by HLL for reference purpose) and soft PVC Needle cover (fitment & locking properties).
9. Sterilization / Autoclaving requirement: Components must be stable for autoclaving and it should not crack or bend on autoclaving.
10. Maximum allowable shrinkage on autoclaving: Less than 5%

HLL/AFT/MTLS/BB/TITAN/NC-RC /2018-21

एचएलएल लाइफकेयर लिमिटेड /HLL LIFECARE LIMITED

(भारत सरकार का उद्यम) / (A GOVT.OF INDIA ENTERPRISE)

आक्कुलम फैक्टरी , श्रीकार्यम पी .ओ / AKKULAM FACTORY,SREEKARIYAM P.O.

तिरुवन्नतपुरम -695 017 / THIRUVANANTHAPURAM-695 017

फोन नं : 0471 2442642 फाक्स नं : 0471 2441383 / PHONE NO:0471 2442642; FAX NO:0471 2441383;

EMAIL: materialsft@lifecarehll.com

TENDER NO. HLL/AFT/MTLS/BB/TITAN/NC-RC /2018-21

Dated 05/12/2018

SCHEDULE- A

Page 5 of 9

OTHER GENERAL REQUIREMENTS

1. Moulding facility: Supplier should have a Class 1 Lakh (ISO Class 8) clean room facility for the Injection moulding, Components Inspection, Assembling and Primary packing.

2. Injection Moulding Machine: The supplier should have at least one 80 Ton (minimum capacity) good condition Injection moulding machine and same must be kept and operate in Class 1 Lakh clean room.

3. Injection Mould (8 / 16 Cavity): The supplier must fabricate and maintain the Injection Mould (HLL will not bear the Tool cost and maintenance cost)

4. Mould Fabrication and Maintenance: The supplier should have a mould fabrication facility / tie-up with reputed mould manufacturer for the design, fabrication and maintenance of Injection moulds.

5. Autoclaving Facility: The supplier should have a laboratory type autoclave / pressure cooker type sterilization equipment for performing the autoclave test of components.

6. In-process Inspection: Component must be free from flash, bend, embedded dust, black spot, colour change, silver streaks, ovality, deformation at gate point, cracks / hole in the pinch off area of PVC Needle cover, etc. The components must also comply with the dimensional requirements as per the approved drawing.
Frequency of inspection: Every one hour on 3 consecutive shots and the results should be recorded in the production/inspection log sheet.

7. Autoclaving requirement: Components must be free from crack, bend, puncturing at gate point, puncturing of Pinch off Area of PVC Needle cover and excess shrinkage after Autoclaving. (118°C, 35minutes /121°C, 25 minutes).
Frequency of inspection: Every 4 hours on 3 consecutive shots. Allowable shrinkage after autoclaving is less than 8% for PVC component and less than 5% for PP component.

एचएलएल लाइफ़केयर लिमिटेड /HLL LIFECARE LIMITED

(भारत सरकार का उद्यम) / (A GOVT.OF INDIA ENTERPRISE)

आक्कुलम फैक्टरी , श्रीकार्यम पी .ओ / AKKULAM FACTORY,SREEKARIYAM P.O.

तिरुवन्नतपुरम -695 017 / THIRUVANANTHAPURAM-695 017

फोन नं : 0471 2442642 फाक्स नं : 0471 2441383 / PHONE NO:0471 2442642; FAX NO:0471 2441383;

EMAIL: materialsft@lifecarehll.com

TENDER NO. HLL/AFT/MTLS/BB/TITAN/NC-RC /2018-21

Dated 05/12/2018

SCHEDULE- A

Page 6 of 9

OTHER GENERAL REQUIREMENTS

8. Visual Inspection: 100 % visual inspection – all the components must be inspected against visual defects and it must be ensured that, the component are free from flash, bend, embedded dust, black spot, colour change, silver streaks, ovality, deformation at gate point, cracks / hole in the Pinch off Area of PVC Needle cover, wall thickness variation, etc.

9. Packaging: 500 sets of assembled components in a LDPE Cover of 70 micron thickness and such 10 to 15 packets in a master carton having burst strength of 15Kg/cm² and it must be stretch wrapped with LLDPE stretch film of thickness not less than 23 micron.

10. Pre shipment Inspection: Each batch of finished components must be inspected and ensure that, the lot is fully complies with the quality and quantity requirements.

11. Documents: Components must be supplied along with the necessary production & QC documents contain the following details as per the format required by HLL.

a) Production document: Comprising date of production, Name of the operator, Product batch No, Total Qty. produced, Accepted Qty., Rejected Qty., Type of rejection, raw material batch No., Process parameters (Temperature, Pressure, Speed, Injection Time, Hold on time, Cooling time, etc.)

b) QC Document: Contains the details of in-process inspection, finished product Pre shipment inspection details (Batch No, Date, Time, Sample size, Product quality status, Instruments / gauges used, etc.) and PVC raw material test certificate from the supplier.

c) Packaging Details: Date, Shift of production, Batch No, Quantity, QC Passed sticker.

एचएलएल लाइफ़केयर लिमिटेड /HLL LIFECARE LIMITED

(भारत सरकार का उद्यम) / (A GOVT.OF INDIA ENTERPRISE)

आक्कुलम फैक्टरी , श्रीकार्यम पी .ओ / AKKULAM FACTORY,SREEKARIYAM P.O.

तिरुवन्नतपुरम -695 017 / THIRUVANANTHAPURAM-695 017

फोन नं : 0471 2442642 फाक्स नं : 0471 2441383 / PHONE NO:0471 2442642; FAX NO:0471 2441383;

EMAIL: materialsft@lifecarehll.com

TENDER NO. HLL/AFT/MTLS/BB/TITAN/NC-RC /2018-21

Dated 05/12/2018

SCHEDULE- A

Page 7 of 9

OTHER GENERAL REQUIREMENTS

12. Finished product acceptance criteria at HLL:

Sampling plan as per ISO 2859-1.

Inspection level: General inspection level -1.

AQL: 0.4 for visual and dimensional inspection,

AQL: 0.1 for critical parameters (crack on component, deformation and puncturing of gate point and puncturing of Pinch off Area of PVC Needle cover after autoclaving).

Example: 125 nos. of components will be tested from each lot (lot size: 10,001 to 35,000 nos.). If one component fails for visual and dimensional inspection, the lot will be accepted. If 2 components fail, the lot will be rejected.

If any one of the component fails for critical parameters like operational suitability in Automatic Needle Assembly Machine, hole/crack at gate point, leakage through the pinch off area of soft PVC Needle cover (before and after autoclaving), Excess flash/Gate projection, etc., the lot will be rejected.

13. Commencement of Components supply: The supplier should commence the bulk supply of components within three months from the date of LOI / Purchase order. The moulds and components qualifications must be completed before commence the bulk supply of components.

HLL/AFT

एचएलएल लाइफ़केयर लिमिटेड /HLL LIFECARE LIMITED

(भारत सरकार का उद्यम) / (A GOVT.OF INDIA ENTERPRISE)

आक्कुलम फैक्टरी , श्रीकार्यम पी .ओ / AKKULAM FACTORY,SREEKARIYAM P.O.

तिरुवन्नतपुरम -695 017 / THIRUVANANTHAPURAM-695 017

फोन नं : 0471 2442642 फाक्स नं : 0471 2441383 / PHONE NO:0471 2442642; FAX NO:0471 2441383;

EMAIL: materialsft@lifecarehll.com

TENDER NO. HLL/AFT/MTLS/BB/TITAN/NC-RC /2018-21

Dated 05/12/2018

SCHEDULE- A
Page 8 of 9

NOTE

1. The components are meant to use in **fully automatic Needle assembly machine** and hence the dimensional & other quality parameters are highly critical for the trouble free operation of the automatic assembly machine.
2. The soft PVC Needle cover and Polypropylene Re-cappable cover must be assembled together immediately after moulding and must perform 100% visual inspection of the components. The intension of assembling process is to avoid the bending property of soft PVC Needle cover during storage, handling and transportation.
3. The assembling process must be done in a controlled clean room environment (at least class 1 Lakh clean room) and the operators must follow the cGMP practice. The moulded components must be free from embedded particles and other type of material dust.
4. There should not be any leakage through the Pinch off area of the PVC needle cover (before and after autoclaving) and at the same time the pinch off portion must be easily breakable after autoclaving (on twisting 90° to 270°).

HLL/AFT/

एचएलएल लाइफ़केयर लिमिटेड /HLL LIFECARE LIMITED

(भारत सरकार का उद्यम) / (A GOVT.OF INDIA ENTERPRISE)

आक्कुलम फैक्टरी , श्रीकार्यम पी .ओ / AKKULAM FACTORY,SREEKARIYAM P.O.

तिरुवन्नतपुरम -695 017 / THIRUVANANTHAPURAM-695 017

फोन नं : 0471 2442642 फाक्स नं : 0471 2441383 / PHONE NO:0471 2442642; FAX NO:0471 2441383;

EMAIL: materialsft@lifecarehll.com

TENDER NO. HLL/AFT/MTLS/BB/TITAN/NC-RC /2018-21

Dated 05/12/2018

SCHEDULE- A

Page 9 of 9

The quantity mentioned below is only approximate annual requirement and HLL reserves the right to modify it at any time during the contract period. The contractor is bound to execute all the supply orders placed during the contract period.

Approximate monthly required quantity: 5 Lakhs sets of components

APPROXIMATE QUANTITY REQUIRED			
ITEM CODE: 1010110059			
UNIT	LOCATION	QUANTITY (SETS)	
AKKULAM	TRIVANDRUM	1st Year	36 Lakh
		2nd Year	40 Lakh
		3rd Year	50 Lakh

We hereby agree to supply the above materials as per the specification listed herein.

PLACE:

DATE:

NAME & SIGNATURE OF THE APPLICANT
(WITH OFFICE SEAL)

एचएलएल लाइफकेयर लिमिटेड /HLL LIFECARE LIMITED

(भारत सरकार का उद्यम) / (A GOVT.OF INDIA ENTERPRISE)

आक्कुलम फैक्टरी , श्रीकार्यम पी .ओ / AKKULAM FACTORY,SREEKARIYAM P.O.

तिरुवन्नतपुरम -695 017 / THIRUVANANTHAPURAM-695 017

फोन नं : 0471 2442642 फाक्स नं : 0471 2441383 / PHONE NO:0471 2442642; FAX NO:0471 2441383;

EMAIL: materialsft@lifecarehll.com

TENDER NO. HLL/AFT/MTLS/BB/TITAN/NC-RC /2018-21

Dated 05/12/2018

SCHEDULE B

Page 1 of 1

TECHNICAL BID

QUESTIONNAIRE TO BE FILLED FOR MINIMUM ELIGIBILITY CRITERIA

Material: Needle cover (PVC) with Outer PP cover

1.	Are you a manufacturer?	YES/NO
2.	Are you an authorised agent? In case of authorised agent following documents from the Principal supplier should have to be enclosed Letter confirming the agency from the Manufacturer valid for 2018-21 Letter from the manufacturer that they also agree to abide by all the terms and conditions of this tender	YES/NO
3.	What is your annual production / process capacity? Out of the above how much can you supply to HLL per month?	
4.	Do you have testing facility to check HLL's parameters? If yes, will you be issuing test certificates for each Sample/ batch/ lot	YES/NO
5.	Do you have experience in manufacturing of medical grade moulded components including mould development and maintenance? If YES, state details	YES/NO
6.	Do you have class 1 Lakh (ISO Class-8) clean room for the Moulding of medical components? If NOT are you ready to give firm commitment to provide clean room before commencement of components supply (written declaration shall be submitted along with the tender document with due date of completion of clean room facility): It is an Essential Document required for the qualification of Technical Bid.	YES / NO
7.	Do you have mould making facility; If YES, what are the machines available for the fabrication of Injection moulds and how many years' experience you have for the mould fabrication (give details separately).	
8.	Are you an existing supplier to HLL? And if yes, Since when	YES/NO
9.	Are you an approved vendor of Akkulam Factory?	YES/NO
10.	EMD furnished or not	YES/NO
11.	Tender Fee furnished or not	YES/NO
12.	Declaration as per Schedule G	YES/NO
13.	What is your Annual Turn over for the last three years?	

All the information provided herein are true & correct

PLACE:

DATE:

NOTE: Forms must be completed in all respect and supported by relevant documents.

NAME & SIGNATURE OF THE APPLICANT

(WITH OFFICE SEAL)

एचएलएल लाइफ़केयर लिमिटेड /HLL LIFECARE LIMITED

(भारत सरकार का उद्यम) / (A GOVT.OF INDIA ENTERPRISE)

आक्कुलम फैक्टरी , श्रीकार्यम पी .ओ / AKKULAM FACTORY,SREEKARIYAM P.O.

तिरुवन्नतपुरम -695 017 / THIRUVANANTHAPURAM-695 017

फोन नं : 0471 2442642 फाक्स नं : 0471 2441383 / PHONE NO:0471 2442642; FAX NO:0471 2441383;

EMAIL: materialsft@lifecarehll.com

TENDER NO. HLL/AFT/MTLS/BB/TITAN/NC-RC /2018-21

Dated 05/12/2018

SCHEDULE -C

Page 1 of 2

TECHNICAL BID

QUESTIONNAIRE

(General information of the manufacturer / supplier)

1. Name & Address of the Supplier with :
(a) Telephone No.
(b) Fax No.
(c) E-mail Address
(d) Name of contact person
(e) Whether proprietary/partnership/
Limited company.
(f) Specify whether SSI / MSME unit
(g) **Udyog Aadhar No (copy must enclosed)** :
2. How many years have you been in the :
business of manufacturing/selling?
3. What is your annual production capacity :
4. Indicate the quantity you can supply HLL :
per month
5. What would be the minimum period :
required to deliver the ordered quantity
from the date of confirmed purchase
order?
6. Have you been a supplier to any Blood bag :
Manufacturer, if so give details of the
name, address, quantity/ values of
orders received and executed during the
last three year? (Attach separate sheet)
7. Kindly furnish the name and address of :
the Transporter through whom the rejected
material is to be returned on freight to pay
basis (Ref. clause d of Schedule E)

एचएलएल लाइफ़केयर लिमिटेड /HLL LIFECARE LIMITED

(भारत सरकार का उद्यम) / (A GOVT.OF INDIA ENTERPRISE)

आक्कुलम फैक्टरी , श्रीकार्यम पी .ओ / AKKULAM FACTORY,SREEKARIYAM P.O.

तिरुवन्नतपुरम -695 017 / THIRUVANANTHAPURAM-695 017

फोन नं : 0471 2442642 फाक्स नं : 0471 2441383 / PHONE NO:0471 2442642; FAX NO:0471 2441383;

EMAIL: materialsft@lifecarehll.com

TENDER NO. HLL/AFT/MTLS/BB/TITAN/NC-RC /2018-21

Dated 05/12/2018

SCHEDULE - C

Page 2 of 2

TECHNICAL BID

QUESTIONNAIRE

8. What is your Annual Turn Over during the :
last 3 years?
(Copy of P & L and Balance sheet to be attached.)
9. Details of tax registration :-
a) GST No. :
b) HSN Code of the Item :
10. Name & Address of your Banker(s) :
11. A/C no. & Swift Code :
12. PAN Details :
- 13 Any other details :

All the information provided herein is true & correct.

PLACE:

DATE :

NAME & SIGNATURE OF THE APPLICANT

(WITH OFFICE SEAL)

एचएलएल लाइफकेयर लिमिटेड /HLL LIFECARE LIMITED

(भारत सरकार का उद्यम) / (A GOVT.OF INDIA ENTERPRISE)

आक्कुलम फैक्टरी , श्रीकार्यम पी .ओ / AKKULAM FACTORY,SREEKARIYAM P.O.

तिरुवन्नतपुरम -695 017 / THIRUVANANTHAPURAM-695 017

फोन नं : 0471 2442642 फाक्स नं : 0471 2441383 / PHONE NO:0471 2442642; FAX NO:0471 2441383;

EMAIL: materialsft@lifecarehll.com

TENDER NO. HLL/AFT/MTLS/BB/TITAN/NC-RC /2018-21

Dated 05/12/2018

SCHEDULE - D

Page 1 of 1

QUESTIONNAIRE

(Quality testing information of the supplier)

1. Do you have a Quality Control set up? : YES / NO
(If yes)

a) Specify the quality tests you undertake :

b) Specify the reference
Standard followed for the test :

2. Do you have an accreditation? viz., :

a) ISO 9001: 2015 :

b) ISO 13485: 2016 :

c) ISO 18001: 2007 :

d) ISO 14001:2015 :

e) Any National/International -
Laboratory / authority accreditation. :

If yes, for the above, give details along with a copy of Certificate issued by them.

If NOT, are you ready to give firm commitment to acquire ISO 9001 and ISO 13485 certification within six months from the date of commencement of components supply (written declaration shall be submitted along with the tender document with due date of acquiring the certification). : **It is an Essential Document required for the qualification of Technical Bid.**

3. Furnish the details of testing facility with list of testing equipments :

All the information provided herein is true and correct.

Place:

NAME & SIGNATURE OF THE APPLICANT

Date:

(WITH OFFICE SEAL)

एचएलएल लाइफ़केयर लिमिटेड /HLL LIFECARE LIMITED

(भारत सरकार का उद्यम) / (A GOVT.OF INDIA ENTERPRISE)

आक्कुलम फैक्टरी , श्रीकार्यम पी .ओ / AKKULAM FACTORY,SREEKARIYAM P.O.

तिरुवन्नतपुरम -695 017 / THIRUVANANTHAPURAM-695 017

फोन नं : 0471 2442642 फाक्स नं : 0471 2441383 / PHONE NO:0471 2442642; FAX NO:0471 2441383;

EMAIL: materialsft@lifecarehll.com

TENDER NO. HLL/AFT/MTLS/BB/TITAN/NC-RC /2018-21

Dated 05/12/2018

SCHEDULE - E

Page 1 of 5

TERMS & CONDITIONS

1. The Tender should be completed in all respects and submitted along Tender Fees (non-refundable) and EMD. Incomplete tenders are liable to be rejected.
2. Unsealed Tenders received are liable to be rejected and this will be at the sole risk of the Tenderer.
3. The EMD of successful bidders will be converted to Security Deposit and will be refunded at the end of contract period.
4. (a) The quoted rate shall be valid for a period of three years, during which period, no price escalation and no change in terms and conditions will be allowed on any ground.

2. In the event of failure on the part of the supplier to supply the material as per the delivery schedule or supply material at the agreed rate during the contract period, HLL would procure the material from alternate source at the risk and cost of the supplier. **In such cases, the additional cost incurred will be recovered from the supplier.**

(c) Failure to supply the material for any of the above reasons will also entail forfeiture of Security Deposit and even blacklisting of the supplier for a minimum period of two years.

- i. Conditional tenders / tenders with deviation will not be considered.
- ii. The quantity mentioned herein is approximate annual requirement and in case the company requires less/more quantity, the supplier should be prepared to effect supply at short notice at the agreed rate, terms and conditions.
- iii. HLL reserves the right to split up the quantity and place the order on more than a supplier and also reserves the right to accept or reject the offer without assigning any reason.

एचएलएल लाइफ़केयर लिमिटेड /HLL LIFECARE LIMITED

(भारत सरकार का उद्यम) / (A GOVT.OF INDIA ENTERPRISE)

आक्कुलम फैक्टरी , श्रीकार्यम पी .ओ / AKKULAM FACTORY,SREEKARIYAM P.O.

तिरुवन्नतपुरम -695 017 / THIRUVANANTHAPURAM-695 017

फोन नं : 0471 2442642 फाक्स नं : 0471 2441383 / PHONE NO:0471 2442642; FAX NO:0471 2441383;

EMAIL: materialsft@lifecarehll.com

TENDER NO. HLL/AFT/MTLS/BB/TITAN/NC-RC /2018-21

Dated 05/12/2018

SCHEDULE - E

Page 2 of 5

iv. The tender is liable to be suspended or cancelled at anytime at the discretion of the company without assigning any reason.

In the event of placing orders: -

- a. Sample should be submitted and got approved before effecting bulk supply.
- b. The remaining period of shelf life of material on arrival at our stores should be minimum 5/6th of the total shelf life.
- c. Test Report of the product is to be attached with each consignment batch wise specifying therein the readings of the final test.
- d. In case of rejection (At the time of incoming inspection or during the production stage), the material should be taken back at supplier's risk and cost within 7 days of intimation from HLL. The cost of rejected material will be deducted from the running bills of the supplier. The procedure in this regard would be as follows:-
 - a) Material shall be returned through the Transporter indicated in Schedule C or through our approved Transporter on freight to-pay basis.
 - b) Alternatively the rejected material shall be destroyed at our end.
 - c) The cost incurred for disposal of the rejected material shall be recovered from supplier.
 - d) The supplier is required to replace the rejected material failing which HLL reserves the right to procure the material from alternate source(s) at supplier's risk and cost.
- e. A certificate confirming that the product offered is environment friendly i.e., non-hazardous to the environment is to be enclosed with the Techno-Commercial Bid (if applicable).
- f. The supplier agrees to supply strictly as per the order terms in respect of quantity and quality. HLL reserves the right not to receive material beyond the delivery date given in the order.

एचएलएल लाइफ़केयर लिमिटेड /HLL LIFECARE LIMITED

(भारत सरकार का उद्यम) / (A GOVT.OF INDIA ENTERPRISE)

आक्कुलम फैक्टरी , श्रीकार्यम पी .ओ / AKKULAM FACTORY,SREEKARIYAM P.O.

तिरुवन्नतपुरम -695 017 / THIRUVANANTHAPURAM-695 017

फोन नं : 0471 2442642 फाक्स नं : 0471 2441383 / PHONE NO:0471 2442642; FAX NO:0471 2441383;

EMAIL: materialsft@lifecarehll.com

TENDER NO. HLL/AFT/MTLS/BB/TITAN/NC-RC /2018-21

Dated 05/12/2018

SCHEDULE - E

Page 3 of 5

- g. Acceptance of the delayed supplies and excess quantity is solely at the discretion of HLL. In the case of excess supply the excess quantity shall be returned back through the Transporter indicated in Schedule C (clause 7) or our authorized transporter on freight to pay basis.
- h. The parties have to abide by delivery schedule given in the supply order strictly. Penalty @ 0.5% value of the materials per week of delay subject to a maximum of 7.5% of the value of the supply defaulted will be imposed if material is accepted by the company after the stipulated delivery period
- i. HLL reserves the right to inspect the facilities for GMP by their officials or by an authorized independent third party agency for compliance with or without prior intimation during day time (6 AM to 6 PM).
- j. Within the scope of the contract, the purchaser may, at any time by a written order to the contractor, amend one or more of the following.
- Drawings, Designs, specifications and components operational requirement (During the mould development stage and qualification stage).
 - The method of packing and shipment.
 - The consignee and/ or the place of delivery.
 - The service to be provided by the contractor.
- k. The party should not subcontract the operation and also do not change the production facility without inspection, approval and confirmation by HLL .
- l. All dispatch documents like delivery note/challan, packing list and invoice should contain the following details
- Supply Order No.& date
 - Description of items as contained in the supply Order.
 - Quantity dispatched
 - Manufacturing date.
 - Total Number of packages/ serially numbered
 - Test certificate
 - HLL's GST No.

The L.R No. / AWB /RR No. and Invoice No. should be intimated immediately after dispatch of the material by e-mail/fax

एचएलएल लाइफकेयर लिमिटेड /HLL LIFECARE LIMITED

(भारत सरकार का उद्यम) / (A GOVT.OF INDIA ENTERPRISE)

आक्कुलम फैक्टरी , श्रीकार्यम पी .ओ / AKKULAM FACTORY,SREEKARIYAM P.O.

तिरुवन्नतपुरम -695 017 / THIRUVANANTHAPURAM-695 017

फोन नं : 0471 2442642 फाक्स नं : 0471 2441383 / PHONE NO:0471 2442642; FAX NO:0471 2441383;

EMAIL: materialsft@lifecarehll.com

TENDER NO. HLL/AFT/MTLS/BB/TITAN/NC-RC /2018-21

Dated 05/12/2018

SCHEDULE - E

Page 4 of 5

m. The following information shall be stenciled or labelled on the exterior of the packing in bold letters, clearly visible, at least 50mm high with waterproof ink.

a. Name of Product (as given in supply Order)

b. Date of Manufacture (Monthly/Yearly)

c. Quantity

d. Instruction off storage and handling

e. Name & Address of Manufacturer

f. Company's address in full

g. All packages should be separately numbered and it should appear on top of the packages with proper labelling.

1. The following documents should accompany the consignment

a. Invoice in triplicate

b. Delivery Note/Challan

c. Packing List

d. LR/AWB/RR No.

e. E-way Bill, etc.

n. Mode of Transport shall be by road, unless otherwise specified. The materials shall be sent through the Transporter who has been granted a Certificate of Registration for transportation of goods as per Carriage by Road Act 2007.

o. Payment shall be made by cheque/RTGS with in 30 days of receipt, inspection and acceptance of the material.

p. The jurisdiction of any dispute, suits and proceedings arising out of this tender shall be only in the court of Thiruvananthapuram as the case may be.

.....

एचएलएल लाइफ़केयर लिमिटेड /HLL LIFECARE LIMITED

(भारत सरकार का उद्यम) / (A GOVT.OF INDIA ENTERPRISE)

आक्कुलम फैक्टरी , श्रीकार्यम पी .ओ / AKKULAM FACTORY,SREEKARIYAM P.O.

तिरुवन्नतपुरम -695 017 / THIRUVANANTHAPURAM-695 017

फोन नं : 0471 2442642 फाक्स नं : 0471 2441383 / PHONE NO:0471 2442642; FAX NO:0471 2441383;

EMAIL: materialsft@lifecarehll.com

TENDER NO. HLL/AFT/MTLS/BB/TITAN/NC-RC /2018-21

Dated 05/12/2018

SCHEDULE - E

Page 5 of 5

INDEMINITY CLAUSE:

If the supplier fails to execute the order within the time prescribed for the delivery of goods ordered or violates or infringes the existing rates as agreed to as mentioned in the supply order, the supplier shall and will indemnify the company against all losses or damages whatsoever to be incurred or sustained including the legal cost or expenses incurred by the company by reason of non-delivery of goods at agreed quantity and rate with in the time specified in the supply order. The company will initiate legal action if the supplier fails to execute the supply order as per the schedule in the supply order for the actual loss suffered. No quantity tolerance will be permitted in this regard unless otherwise prior approval is taken by the company before dispatching any excess quantity supplied which shall be returned back on freight to pay basis at the risk of the supplier. Responsiveness of the Bid shall be at the discretion of HLL.

The supplier shall have no right to change the quantity stipulated in the supply order.

Bid pronounced Non Responsive by HLL shall be summarily rejected.

The decision of HLL will be final and no correspondence on this shall be entertained.

We have read and understood the above conditions and agree to abide by the same.

PLACE:

DATE:

NAME AND SIGNATURE OF THE APPLICANT

(WITH OFFICE SEAL)

एचएलएल लाइफकेयर लिमिटेड /HLL LIFECARE LIMITED

(भारत सरकार का उद्यम) / (A GOVT.OF INDIA ENTERPRISE)

आक्कुलम फैक्टरी , श्रीकार्यम पी .ओ / AKKULAM FACTORY,SREEKARIYAM P.O.

तिरुवन्नतपुरम -695 017 / THIRUVANANTHAPURAM-695 017

फोन नं : 0471 2442642 फाक्स नं : 0471 2441383 / PHONE NO:0471 2442642; FAX NO:0471 2441383;

EMAIL: materials@lifecarehll.com

TENDER NO. HLL/AFT/MTLS/BB/TITAN/NC-RC /2018-21

Dated 05/12/2018

SCHEDULE - F

Page 1 of 2

QUESTIONNAIRE FOR VENDOR DEVELOPMENT

(TO BE FILLED BY NEW VENDORS)

NAME OF PRODUCT:

1) Name & Address of the Manufacturer :

- a) Telephone No. :
b) Fax No. :
c) E-mail Address :
d) Name of contact person :
e) (i) Whether proprietary/partnership/
Limited company. :
(ii) Furnish Name/'s, address :
phone nos. of Proprietor/
Managing partner/ M.D / Director's
(Attach separate sheet)

f) Specify whether SSI / MSME unit : Yes / No.

If yes please mention Udyog Aadhar and attach copy

g) If Yes, pl specify if your unit is owned by :
SC/ST entrepreneur

2) Details of tax registration :-

a) GST No. :

3) Name & Address of your Banker(s):

Account no. :

Swift Code :

4) Annual Turn over :

5) Do you have a Quality Control department? If yes, give the details of the facility. : Yes/No

6) a) Do you have inspection for incoming materials : Yes/No

b) Do you have in process inspection facilities : Yes/No

c) Do you have final inspection of the product : Yes/No

एचएलएल लाइफ़केयर लिमिटेड /HLL LIFECARE LIMITED

(भारत सरकार का उद्यम) / (A GOVT.OF INDIA ENTERPRISE)

आक्कुलम फैक्टरी , श्रीकार्यम पी .ओ / AKKULAM FACTORY,SREEKARIYAM P.O.

तिरुवन्नतपुरम -695 017 / THIRUVANANTHAPURAM-695 017

फोन नं : 0471 2442642 फाक्स नं : 0471 2441383 / PHONE NO:0471 2442642; FAX NO:0471 2441383;

EMAIL: materialsft@lifecarehll.com

TENDER NO. HLL/AFT/MTLS/BB/TITAN/NC-RC /2018-21

Dated 05/12/2018

SCHEDULE - F

Page 2 of 2

7) Do you have an accreditation? viz.,

a) ISO 9001: 2015 : YES / NO

b) ISO 13485: 2016 : YES / NO

c) ISO 18001: 2007 : YES / NO

d) ISO 14001:2015 : YES / NO

e) Any National/International -
Laboratory / authority accreditation. : YES / NO

If yes, for the above, give details along with a copy of Certificate issued by them.

8) Furnish the details of testing equipments.

9) Have you been assessed previously by HLL : Yes/No

10) List of customers (Give the details)

a) Government Dept. / PSU's

b) Private Sector

Place :

Date :

NAME AND SIGNATURE OF THE VENDOR
(Office Seal)

This is to be filled up by **HLL LIFECARE LIMITED, THIRUVANANTHAPURAM**

Recommendation/Remarks of the committee

Committee Members:

1. Head of Quality Control/Head of Technical Services and Material Testing

2.Head of User Department

3.Head of Purchase Department

एचएलएल लाइफ़केयर लिमिटेड /HLL LIFECARE LIMITED

(भारत सरकार का उद्यम) / (A GOVT.OF INDIA ENTERPRISE)

आक्कुलम फैक्टरी , श्रीकार्यम पी .ओ / AKKULAM FACTORY,SREEKARIYAM P.O.

तिरुवन्नतपुरम -695 017 / THIRUVANANTHAPURAM-695 017

फोन नं : 0471 2442642 फाक्स नं : 0471 2441383 / PHONE NO:0471 2442642; FAX NO:0471 2441383;

EMAIL: materialsft@lifecarehll.com

TENDER NO. HLL/AFT/MTLS/BB/TITAN/NC-RC /2018-21

Dated 05/12/2018

SCHEDULE - G

Page 1 of 1

TECHNICAL BID

ITEM: NEEDLE COVER (PVC) WITH OUTER PP COVER

DECLARATION

We confirm having read and understood all the specifications, instructions, forms, terms and conditions and other requirements of the above tender (both expressed and implied) in full and that we agree to abide by all without any deviation.

SIGNATURE SEAL OF THE APPLICANT

NAME AND ADDRESS OF APPLICANT

HLL/AFT/MTLS/BB/TITAN/NC-RC/2018-21

एचएलएल लाइफ़केयर लिमिटेड /HLL LIFECARE LIMITED

(भारत सरकार का उद्यम) / (A GOVT.OF INDIA ENTERPRISE)

आक्कुलम फैक्टरी , श्रीकार्यम पी .ओ / AKKULAM FACTORY,SREEKARIYAM P.O.

तिरुवन्नतपुरम -695 017 / THIRUVANANTHAPURAM-695 017

फोन नं : 0471 2442642 फाक्स नं : 0471 2441383 / PHONE NO:0471 2442642; FAX NO:0471 2441383;

EMAIL: materialsft@lifecarehll.com

TENDER NO. HLL/AFT/MTLS/BB/TITAN/NC-RC /2018-21

Dated 05/12/2018

PRICE BID FORMS

FOR

NEEDLE COVER (PVC) WITH OUTER PP COVER

HLL/AFT/MTLS/BB/TITAN/NC-RC/2018-21

एचएलएल लाइफकेयर लिमिटेड /HLL LIFECARE LIMITED

(भारत सरकार का उद्यम) / (A GOVT.OF INDIA ENTERPRISE)

आक्कुलम फैक्टरी , श्रीकार्यम पी .ओ / AKKULAM FACTORY,SREEKARIYAM P.O.

तिरुवन्नतपुरम -695 017 / THIRUVANANTHAPURAM-695 017

फोन नं : 0471 2442642 फाक्स नं : 0471 2441383 / PHONE NO:0471 2442642; FAX NO:0471 2441383;

EMAIL: materialsft@lifecarehll.com

TENDER NO. HLL/AFT/MTLS/BB/TITAN/NC-RC /2018-21

Dated 05/12/2018

Page 1 of 1

PRICE BID

PRICE PARTICULARS	Rate / 1000 sets (in INR)		
	For the 1 st year	For the 2 nd year	For the 3 rd year
BASIC PRICE			
FREIGHT			
OTHERS, IF ANY (PLEASE SPECIFY)			
GST (%)			
TOTAL DELIVERED RATE AT HLL STORES			

HSN Code of the Item:

Commencement of Bulk supply with in how many week/
days including mould development and part qualification }

Note: The average of three year's quoted price will be the base for fixing the L1 (Lowest quoted) party.

PLACE:

DATE:

NAME & SIGNATURE OF THE APPLICANT
(WITH OFFICE SEAL)