

# **TENDER DOCUMENT**

**SUPPLY OF METAL MOULD ASSEMBLY FOR CONVEYOR TYPE  
ELECTRONIC TESTING MACHINE**

**AT**

**HLL LIFECARE LIMITED,  
CENTRAL ENGINEERING DIVISION  
PEROORKADA FACTORY,  
THIRUVANANTHAPURAM – 695 005,  
KERALA, INDIA.**

**Phn: 0471 – 2433374, 2437270**

**IFB No. : HLL/CED/PFT/CET-BO/METAL MOULD/2016**

**DATE : 08-08-2016**

	<b>HLL LIFECARE LIMITED</b> <b>(A Government of India Enterprise)</b> <b>CENTRAL ENGINEERING DIVISION</b> <b>PEROOKADA PO, THIRUVANANTHAPURAM-</b> <b>695 005, KERALA, INDIA</b> <b>Phn: 0471 – 2437270, 2433374</b>	
	TENDER FOR THE SUPPLY OF METAL MOULD ASSEMBLY FOR CONVEYOR TYPE ELECTRONIC TESTING MACHINE (10 STATION ET MACHINE)	
PLANT: PFT	REF: IFB No.HLL/CED/PFT/CET-BO/METAL MOULD /2016	DATE :08.08.2016

**INVITATION FOR BIDS (IFB)**

**IFB No : HLL/CED/PFT/CET-BO/METAL MOULD /2016**

**DTAE : 08-08-2016**

HLL Lifecare Limited (HLL), a Government of India Enterprise is in the process of fabricating Conveyor Type Electronic Testing Machine for testing male condoms. For the said project, sealed and super scribed bids are invited from competent and experienced Suppliers/Contractors who are capable to do the following work meeting the requirements as per our tender.

Sl. No	Brief Description of Item/Work	Qty
1	Supply of Metal Mould Assembly for Conveyor Type Electronic Testing Machine as per drawing and tender specifications and schedule at HLL, Peroorkada Factory, Thiruvananthapuram	As per Schedule IV

2. The bid documents will be available up to 15.00 Hrs. on the previous working day of the opening of the bids.
3. The Tender Documents can also be downloaded from our Website [www.lifecarehll.com](http://www.lifecarehll.com) from the date of issue of tender document. Tender forms shall be filled in ink or typed. No tender filled in pencil shall be considered. The tenderer shall sign and seal the form at each page and at the end, in token of acceptance of all the terms and conditions of the tender. Any subsequent changes/amendments will be published only in our website
4. The scheduled date for issue, receipt and opening of bids is as follows.
  - a) Date of issue of tender document - 08-08-2016 onwards
  - b) Last date and time for receipt of bids - 18-08-2016 up to 15.00 Hrs.
  - c) Date and time of opening of bids - 18-08-2016, 15.30 Hrs.
  - d) Address for communication, receipt and place of opening of bids:

Deputy Chief Engineer (CED)  
Central Engineering Division,  
HLL Lifecare Limited (A Government of India Enterprise),  
PB No 2, Peroorkada, Thiruvananthapuram – 695005,  
Kerala State, India  
Ph: (++91 471) 2433374, 2437270 –501,502,503  
E-mail: rajeevrv@lifecarehll.com, krknair@lifecarehll.com

	<b>HLL LIFECARE LIMITED</b> <b>(A Government of India Enterprise)</b> <b>CENTRAL ENGINEERING DIVISION</b> <b>PEROOKADA PO, THIRUVANANTHAPURAM-</b> <b>695 005, KERALA, INDIA</b> <b>Phn: 0471 – 2437270, 2433374</b>	
	TENDER FOR THE SUPPLY OF METAL MOULD ASSEMBLY FOR CONVEYOR TYPE ELECTRONIC TESTING MACHINE (10 STATION ET MACHINE)	
PLANT: PFT	REF: IFB No.HLL/CED/PFT/CET-BO/METAL MOULD /2016	DATE :08.08.2016

5. The completed and sealed bid documents should be submitted to **Deputy Chief Engineer(CED)**, in the above address. The outer cover should bear the Enquiry No, closing date and General description of item tendered, and the words "DO NOT OPEN BEFORE" 15.30 Hrs (IST) on ----- (Indicate the Closing Date).
- 6.
7. Bids will be opened in the presence of Bidders representative(s) who choose to attend on the specified date and time, at the office of HLL at the address given in Clause 2 (d) above.
8. In the event of the date specified for bid receipt and opening being declared as a closed holiday for the above purchaser's office, the due date for submission of bids and opening of bids will be the following working day at the appointed times.
9. HLL may, at its discretion, extend this deadline for submission of bids by amending the Bid Documents or any other reasons, in which case all rights and obligations of HLL and Bidders previously subject to the deadline will thereafter be subject to the deadline as extended.
10. HLL will not be held responsible for the postal delay, if any, in the delivery of the bidding document or the non-receipt of the same. Bids sent by Telex/Fax/Telegraph will not be accepted.
11. The company reserves the right to club or split the items of works, change the qualifying criteria at their discretion and to reject or cancel the Invitation for bids without assigning any reason thereof.
12. In addition to the invitation for bids, the bidding documents include the following schedules.

SCHEDULE	- I	: Conditions of Bid
SCHEDULE	- II	: Detailed Specification of Item
SCHEDULE	- III	: Conditions of Contract
SCHEDULE	- IV	: Format of Quoting
SCHEDULE	- V	: Acceptance Form

**DEPUTY CHIEF ENGINEER (CENTRAL ENGINEERING DIVISION)**

	<b>HLL LIFECARE LIMITED</b> <b>(A Government of India Enterprise)</b> <b>CENTRAL ENGINEERING DIVISION</b> <b>PEROOKADA PO, THIRUVANANTHAPURAM-</b> <b>695 005, KERALA, INDIA</b> <b>Phn: 0471 – 2437270, 2433374</b>	
	TENDER FOR THE SUPPLY OF METAL MOULD ASSEMBLY FOR CONVEYOR TYPE ELECTRONIC TESTING MACHINE (10 STATION ET MACHINE)	
PLANT: PFT	REF: IFB No.HLL/CED/PFT/CET-BO/METAL MOULD /2016	DATE :08.08.2016

## SCHEDULE I

### CONDITIONS OF BID

#### 1. Definitions

- a. **“Invitation For Bid”** shall mean and include the present document, and such other complements and agenda, which may subsequently be issued in this connection.
- b. **“Purchaser/Owner”** shall mean HLL Lifecare Limited, (Thiruvananthapuram) or its units thereof.
- c. **“Bidder”** shall mean the person, firm of Corporation submitting a bid against this invitation for bid and shall also include his agents and representatives.
- d. **“Supplier/Contractor”** shall mean the bidder whose bid has been accepted and shall also include his successors and assigns, agents and representatives.
- e. **“Contract”** means signed acceptance of the Letter of Intend, if issued, and order by the supplier.
- f. **“Site”** shall mean **HLL Lifecare Limited, Peroorkada Factory, Thiruvananthapuram – 695005, Kerala**

#### 2. Bid Information and Period of Validity

2.1 The Bid must include the following information,

- a. Enquiry / IFB No.
- b. Promised Delivery Schedule for each item/work.
- c. Certificate that bid is in total conformity with the specifications and terms and conditions mentioned in the bid document and if not, list of exclusions, and/or exceptions.
- d. All information requested in the specifications, dimensional drawings, technical literature describing the make offered, material etc., as specified in the bid document.
- e. The Price should be quoted as per the following:
  - i) The Bidder shall indicate all prices including basic price, the relevant duties and taxes, other levies, packing & forwarding charges, charges for inland transportation and other local costs incidental to delivery of the goods to supplier's site, etc. on the appropriate price schedule (FORMAT FOR QUOTING – SCHEDULE IV) attached to these documents for completing the above work as per the Specification, Terms and Conditions as specified in the Bid Documents. Civil work is excluded from the scope of the supplier.
  - ii) Bidder must quote for unit price and total price based on the requirement shown in the bid document.

	<b>HLL LIFECARE LIMITED</b> <b>(A Government of India Enterprise)</b> <b>CENTRAL ENGINEERING DIVISION</b> <b>PEROOKADA PO, THIRUVANANTHAPURAM-</b> <b>695 005, KERALA, INDIA</b> <b>Phn: 0471 – 2437270, 2433374</b>	
	TENDER FOR THE SUPPLY OF METAL MOULD ASSEMBLY FOR CONVEYOR TYPE ELECTRONIC TESTING MACHINE (10 STATION ET MACHINE)	
PLANT: PFT	REF: IFB No.HLL/CED/PFT/CET-BO/METAL MOULD /2016	DATE :08.08.2016

- iii) Price should be firm without any escalation on any account until the order is completely fulfilled.
- iv) All other documents/certificate/information as specified in the bid document.

2.2 Bids shall remain valid for **90 days** after the date of bid opening prescribed by the Purchaser.

### 3. Format and Signing of Bid

- 3.1 All pages of the bid, except for un-amended printed literature shall be signed by the person or persons signing the bid.
- 3.2 Bids shall be made in English.
- 3.3 The bid shall contain no interlineations, erasures or overwriting except as necessary to correct errors made by the Bidder, in which case such corrections shall be signed by the person or persons signing the bid.

### 4. Submission of Bids

#### Sealing and Marking of Bids

- 4.1 The bids should be submitted in duplicate. The Bidder shall seal the original and each copy of the bid in an inner and then in an outer envelope, duly marked the envelopes as "original" and "copy".
- 4.2 The inner and outer envelopes shall be:
  - (a) Addressed to the Purchaser in the following address,

**Deputy Chief Engineer (CED),**  
HLL Lifecare Limited  
Central Engineering Division,  
Peroorkada. PO, Thiruvananthapuram – 695005,  
Kerala, India  
Phn: 0471 – 2437270, 2433374  
E-mail:rajeevrv@lifecarehll.com, krknair@lifecarehll.com
  - (b) Bear the Enquiry No, closing date and General description of item tendered, and the words "DO NOT OPEN BEFORE" 15.30 Hrs (IST) on ----- (Indicate the Closing Date).
- 4.3 The inner envelopes shall indicate the name and address of the Bidder. If the outer envelope is not sealed and marked as indicated above, the Purchaser will assume no responsibility for the bid's misplacement or premature opening.

	<p align="center"><b>HLL LIFECARE LIMITED</b>  <b>(A Government of India Enterprise)</b>  <b>CENTRAL ENGINEERING DIVISION</b>  <b>PEROOKADA PO, THIRUVANANTHAPURAM-</b>  <b>695 005, KERALA, INDIA</b>  <b>Phn: 0471 – 2437270, 2433374</b></p>	
	<p align="center">TENDER FOR THE SUPPLY OF METAL MOULD  ASSEMBLY FOR CONVEYOR TYPE  ELECTRONIC TESTING MACHINE (10 STATION  ET MACHINE)</p>	
PLANT: PFT	REF: IFB No.HLL/CED/PFT/CET-BO/METAL MOULD /2016	DATE :08.08.2016

4.4 Bids should be hand delivered or sent by courier to ensure timely arrival. Telex, cable, e-mail or facsimile bids will be rejected.

**Deadline for submission of Bids**

4.5 The bids will be received by the Purchaser in the above given address (4.2.a) not later than the date and time specified in the Invitation for Bids.

In the event of the specified date for submission of Bids being declared a holiday for the Purchaser, the bids will be received up to the appointed time on the next working day.

4.6 The purchaser may, at its discretion, extend this deadline for submission of bids by amending the Bid Documents or any other reasons in which case all rights and obligations of the Purchaser and Bidders previously subject to the deadline will thereafter be subject to the deadline as extended.

4.7 It is the responsibility of the bidders to see that the completed bidding documents whether sent by post or by courier or by person are received in the office of **Deputy Chief Engineer(CED)**, in the above address by the date and time stipulated for receipt as above failing which the bid would be considered late and rejected. Purchaser will not be held responsible for the postal delay, if any, in the delivery of the bidding document or the non-receipt of the same. Bids received after due date and time will be rejected. Mere handing over of the bid documents at reception counter or at any other counter or room or person cannot be considered as submission of bid.

**5. Clarification of Bidding Documents**

A prospective Bidder requiring any clarification of the Bidding Documents may notify the Purchaser in writing, or by fax at the purchasers mailing address indicated in the Invitation for Bids. The Purchaser will respond in writing to any request for clarification of Bidding Documents, which it receives not later than 7 days prior to the deadline for submission of Bids prescribed by the Purchaser.

**6. Amendment of Bidding Documents**

6.1 At any time prior to the deadline for submission of bids, the Purchaser may, for any reason, modify the Bidding Documents by amendment.

6.2 The amendment will be notified in writing or fax or telegram or e-mail to all prospective Bidders, which have received the Bidding Documents and will be binding on them.

6.3 In order to afford prospective Bidders reasonable time in which to take the amendment in to account in preparing their bid, the Purchaser may, at its discretion, extend the deadline for the submission of bids.

	<p align="center"><b>HLL LIFECARE LIMITED</b>  <b>(A Government of India Enterprise)</b>  <b>CENTRAL ENGINEERING DIVISION</b>  <b>PEROOKADA PO, THIRUVANANTHAPURAM-</b>  <b>695 005, KERALA, INDIA</b>  <b>Phn: 0471 – 2437270, 2433374</b></p>	
	<p align="center">TENDER FOR THE SUPPLY OF METAL MOULD  ASSEMBLY FOR CONVEYOR TYPE  ELECTRONIC TESTING MACHINE (10 STATION  ET MACHINE)</p>	
PLANT: PFT	REF: IFB No.HLL/CED/PFT/CET-BO/METAL MOULD /2016	DATE :08.08.2016

## 7. Bid Opening by Purchaser

- 7.1 The Purchaser will open bids, in the presence of the bidders' representatives who choose to attend, at the date and time specified and in the location given in this document. The Bidders' representatives who are present shall sign a register evidencing their attendance. In the event of the specified date of bid opening being declared a holiday for the Purchaser, the bids shall be opened at the appointed time and location on the next working day.
- 7.2 The Purchaser will prepare appropriate bid opening register and the same shall be signed by bidders present during the opening of the bids and Purchaser.

## 8. Clarification of bids

To assist in the examination, evaluation and comparison of bids, the purchaser may, at its discretion, ask the bidder for a clarification of its bid. The request for clarification and the response shall be in writing and no change in the price or substance of the bid shall be sought, offered or permitted.

## 9. Preliminary examination

- 9.1 The purchaser will examine the bids to determine whether they are complete, whether any computational errors have been made, whether the documents have been properly signed, whether the bid validity is as required and whether the bids are generally in order.
- 9.2 Arithmetical errors will be rectified on the following basis. If there is a discrepancy between the unit price and the total price that is obtained by multiplying the unit price and quantity, the unit price shall prevail and the total price shall be calculated. If there is a discrepancy between the words and figures, the amount in words shall prevail.
- 9.3 Prior to the detailed evaluation, the purchaser will determine the substantial responsiveness of each bid to the bidding documents. For purposes of these clauses, a substantially responsive bid is one that conforms to specifications and all the terms and conditions of the bidding documents without material deviation. The purchaser's determination of a bid's responsiveness is to be based on the contents of the bid itself without recourse to extrinsic evidence.
- 9.4 A bid determined as not substantially responsive will be rejected by the purchaser and may not subsequently be made responsive by the bidder by correction of the non-conformity.
- 9.5 The purchaser may waive any minor informality or non-conformity or irregularity in a bid, which does not constitute a material deviation, provided such waiver does not prejudice or affect the relative ranking of any bidder.

	<b>HLL LIFECARE LIMITED</b> <b>(A Government of India Enterprise)</b> <b>CENTRAL ENGINEERING DIVISION</b> <b>PEROOKADA PO, THIRUVANANTHAPURAM-</b> <b>695 005, KERALA, INDIA</b> <b>Phn: 0471 – 2437270, 2433374</b>	
	TENDER FOR THE SUPPLY OF METAL MOULD ASSEMBLY FOR CONVEYOR TYPE ELECTRONIC TESTING MACHINE (10 STATION ET MACHINE)	
PLANT: PFT	REF: IFB No.HLL/CED/PFT/CET-BO/METAL MOULD /2016	DATE :08.08.2016

9.6 The purchaser's determination as to the substantial responsiveness or otherwise of each bid or consideration of a minor informality or non-conformity or irregularity is final and conclusive.

#### 10. Evaluation and comparison of bids.

10.1 The purchaser will technically evaluate all bids previously determined to be responsive and compare the bids previously determined to be substantially responsive and technically acceptable.

#### 11. Post – qualification

11.1 Notwithstanding the qualification requirements given in this document, the Purchaser will determine to its satisfaction whether the Bidder selected as having submitted the lowest evaluated responsive bid is qualified to satisfactorily perform the Contract.

11.2 The determination will take into account the Bidder's financial, technical and production capabilities. It will be based upon an examination of the documentary evidence of the Bidder's qualifications submitted by the Bidder, as well as such other information as the Purchaser deems necessary and appropriate.

11.3 The Purchaser reserves the right to negotiate with the lowest evaluated responsive bidder.

11.4 An affirmative determination will be a prerequisite for award of the Contract to the Bidder. A negative determination will result in rejection of the Bidder's bid, in which event the Purchaser will proceed to the next lowest evaluated bid to make a similar determination of that bidder's capabilities to perform satisfactorily.

11.5 Conditional Bids shall not be entertained.

#### 12. Award Criteria

The Purchaser will award the Contract to the successful Bidder whose bid has been determined to be substantially responsive and has been determined as the lowest evaluated bid provided further that the Bidder is determined to be qualified to perform the Contract satisfactorily for the items offered.

#### 13. Notification of Award

13.1 Prior to the expiration of the period of bid validity, the purchaser will notify the successful Bidder in writing by post or by cable or telex or fax, to be confirmed in writing by post, that its bid has been accepted. The notification of award may be sent in the form of Letter of Intend / Work order.



	<b>HLL LIFECARE LIMITED</b> <b>(A Government of India Enterprise)</b> <b>CENTRAL ENGINEERING DIVISION</b> <b>PEROOKADA PO, THIRUVANANTHAPURAM-</b> <b>695 005, KERALA, INDIA</b> <b>Phn: 0471 – 2437270, 2433374</b>	
	TENDER FOR THE SUPPLY OF METAL MOULD ASSEMBLY FOR CONVEYOR TYPE ELECTRONIC TESTING MACHINE (10 STATION ET MACHINE)	
PLANT: PFT	REF: IFB No.HLL/CED/PFT/CET-BO/METAL MOULD /2016	DATE :08.08.2016

13.2 The signed acceptance of the notification of award by the Supplier/Contractor will constitute a concluded contract.

	<b>HLL LIFECARE LIMITED</b> <b>(A Government of India Enterprise)</b> <b>CENTRAL ENGINEERING DIVISION</b> <b>PEROOKADA PO, THIRUVANANTHAPURAM-</b> <b>695 005, KERALA, INDIA</b> <b>Phn: 0471 – 2437270, 2433374</b>	
	TENDER FOR THE SUPPLY OF METAL MOULD ASSEMBLY FOR CONVEYOR TYPE ELECTRONIC TESTING MACHINE (10 STATION ET MACHINE)	
PLANT: PFT	REF: IFB No.HLL/CED/PFT/CET-BO/METAL MOULD /2016	DATE :08.08.2016

## SCHEDULE II

### DETAILED SPECIFICATION OF ITEM

#### **Requirement:**

We are in the process of fabricating Conveyor Type Electronic Testing Machine at our Peroorkada Factory, Thiruvananthapuram for testing male condoms. For the proposed machine, we require the following item as per the specifications given below:

#### **Technical Data and Specification**

**Bearings will be supplied by HLL, to the party.**

Sl.No.	Item	Drawing No.	Quantity
1.	Metal Mould	HLL-CED-D2-086-00	750.00
2.	Sleeve	HLL-CED-D2-081-00	750.00
3.	Shaft	HLL-CED-D2-082-00	750.00
4.	Top cap	HLL-CED-D2-080-00	750.00
5.	Bottom cap	HLL-CED-D2-079-00	750.00
6.	T-Bush	HLL-CED-D2-074-00	750.00
7.	Plane washer	HLL-CED-D2-083-00	750.00
8.	Bush	HLL-CED-D2-084-00	750.00

**It will be the sole responsibility of the party to assemble the metal moulds (with bearings). Only assembled moulds should be supplied to HLL.**

#### **GENERAL CONDITIONS**

- 1) Given specification are indicative only. The supplier should visit the HLL Site at Peroorkada Factory, Thiruvananthapuram and see the machines and also take their own assessments before quoting of bids. Prior permission from HLL shall be taken for visiting the plant. No photographs will be allowed inside the plant. The purchaser will not be responsible for any wrong quotes due to inadequate information.
- 2) The supplier should submit 3 copies of the following documents relevant to his scope of work, two weeks prior to the commissioning of the unit, free of cost.
  1. Instruction/Testing/Operation manual (3 copies)
  2. Maintenance manual/Lubrication Chart (3 copies)
  3. All final drawings - Electrical, mechanical and civil (3 copies)
  4. Relevant Test Certificates, Guarantee Certificate for each item of equipment.
  5. Catalogue and literature on bought outs (3 copies)
  6. Any other related documents

	<b>HLL LIFECARE LIMITED</b> <b>(A Government of India Enterprise)</b> <b>CENTRAL ENGINEERING DIVISION</b> <b>PEROOKADA PO, THIRUVANANTHAPURAM-</b> <b>695 005, KERALA, INDIA</b> <b>Phn: 0471 – 2437270, 2433374</b>	
	TENDER FOR THE SUPPLY OF METAL MOULD ASSEMBLY FOR CONVEYOR TYPE ELECTRONIC TESTING MACHINE (10 STATION ET MACHINE)	
PLANT: PFT	REF: IFB No.HLL/CED/PFT/CET-BO/METAL MOULD /2016	DATE :08.08.2016

- 3) The item should be complete with all accessories and interconnections.
- 4) The bidder should attach to their bid detailed specifications, catalogues and other details of all the items quoted by them.
- 5) Calibration certificates with traceability to National Standards shall be supplied for all the instruments coming under the scope of supply of supplier.
- 6) The supplier should submit necessary test certificates as per relevant standards of material used, free of cost.
- 7) The suppliers should submit the following documents, relevant to their scope of work, two weeks prior to the commissioning of the Unit :
  - a) All final drawings
  - b) Relevant Test Certificates, Guarantee Certificate for each material which are using for fabrication.
  - c) Any other related documents
- 8) Any deviations from the bid documents shall be clearly indicated.
- 9) The bid should be complete with all the relevant details.

	<b>HLL LIFECARE LIMITED</b> <b>(A Government of India Enterprise)</b> <b>CENTRAL ENGINEERING DIVISION</b> <b>PEROOKADA PO, THIRUVANANTHAPURAM-</b> <b>695 005, KERALA, INDIA</b> <b>Phn: 0471 – 2437270, 2433374</b>	
	TENDER FOR THE SUPPLY OF METAL MOULD ASSEMBLY FOR CONVEYOR TYPE ELECTRONIC TESTING MACHINE (10 STATION ET MACHINE)	
PLANT: PFT	REF: IFB No.HLL/CED/PFT/CET-BO/METAL MOULD /2016	DATE :08.08.2016

### SCHEDULE III

#### CONDITIONS OF CONTRACT

#### 1. Price

The price quoted should be inclusive of Basic Price, all applicable taxes and duties including VAT, Entry tax, Octroi & other levies, P&F charges, insurance charges etc for supply of items FOR HLL site. The Supplier should pay entry taxes, as applicable and should be included in the offer.

Price quoted should be firm without any escalation till the order is completely executed.

#### 2. Taxes/Duties/Levies

The supplier/contractor shall be entirely responsible for all taxes including entry tax, duties, license fees, etc. incurred until successful completion of contract. All central, state, municipal taxes, duties and levies payable shall be shown by the bidder separately in the Bid. The Purchaser will issue necessary 'C' Form, if required.

#### Note:

The term 'Machine' means the final and complete equipment/machinery as ordered and does not mean raw material, components, consumable, etc. required for the work. The Purchaser shall not be liable to pay any tax/duty/levy incurred during the transactions between the Supplier and his sub-suppliers and or Agents.

#### 3. Insurance

The supplier shall arrange insurance coverage for transit, storage and erection.

#### 4. Delivery/Completion Period

**The delivery period is 6 weeks from the date of receipt of the supply order. 3 Pcs shall be supplied as sample within 10 days from the date of receipt of supply order and bulk supply shall be made after approving the samples.**

Time being the essence of the Contract, the delivery, stipulated should be strictly adhered to. Delay in delivery/non delivery of the equipment will cause loss and/or damage to Purchaser. The delivery period shall be counted from the date of sending of Purchaser's intimation of acceptance of the Supplier's offer (Letter of Intent (LOI) and/or order).

	<b>HLL LIFECARE LIMITED</b> <b>(A Government of India Enterprise)</b> <b>CENTRAL ENGINEERING DIVISION</b> <b>PEROOKADA PO, THIRUVANANTHAPURAM-</b> <b>695 005, KERALA, INDIA</b> <b>Phn: 0471 – 2437270, 2433374</b>	
	TENDER FOR THE SUPPLY OF METAL MOULD ASSEMBLY FOR CONVEYOR TYPE ELECTRONIC TESTING MACHINE (10 STATION ET MACHINE)	
PLANT: PFT	REF: IFB No.HLL/CED/PFT/CET-BO/METAL MOULD /2016	DATE :08.08.2016

## 5. Terms Of Payment

The payment terms offered are as follows: -

- 60% of the total value of equipment/s will be paid against supply ,inspection and acceptance of the entire item/equipments at site.
- 30% of the value will be paid after successful operation of the machine for a period of 14 days.
- Balance 10% of the value of the equipment/s will be paid against a Performance Bank Guarantee (from a nationalized bank) equal to 10% of the total contract value valid for the guarantee period of one year.

Tax Deduction: All statutory deductions like Income Tax or any other government-imposed liabilities shall be borne by the Supplier/Contractor (as applicable at the time of execution of job) and shall be deducted from each bill submitted by the Supplier/Contractor.

## 6. Guarantee Period

The Guarantee against any possible manufacturing defects shall be given for a period of 18 months from the date of supply and acceptance of the items at HLL site or 12 months from the date of installation, whichever is earlier.

## 7. Liquidated damages for delays

If the equipment is not supplied to the purchaser within the time stipulated in the Order, Purchaser may at their option, either (1) recover from the Supplier/Contractor liquidated damages at the rate of 0.5 % of the total contract value for every week of delay, subject to a maximum of 7.5 % of the total contract value, or (2) at the risk and cost of the Supplier and without prejudice to the other remedies/rights as per the Contract, terminate the order wholly or partially and complete it themselves or reassign it to other Suppliers/Contractors.

## 8. Inspection and Testing

Purchaser shall have the right of access to the Supplier's/Contractor's works at all reasonable times to inspect and measure the progress of execution of the Order. The Supplier/Contractor should make available all tools, instruments, apparatus, equipment, facilities, services and materials to enable the Purchaser's nominee to carryout such inspection/tests without obligations. Notwithstanding such tests/inspection conducted at the Supplier's works from time to time, goods under the Order shall not be dispatched unless they have been finally inspected by the purchaser or inspection waived and dispatch specifically authorized in writing, wherever inspection during various stages of execution of the order and prior to dispatch are specifically provided for in the order, sufficient advance notice shall be given to the purchaser for the purpose, and as a

	<b>HLL LIFECARE LIMITED</b> <b>(A Government of India Enterprise)</b> <b>CENTRAL ENGINEERING DIVISION</b> <b>PEROOKADA PO, THIRUVANANTHAPURAM-</b> <b>695 005, KERALA, INDIA</b> <b>Phn: 0471 – 2437270, 2433374</b>	
	TENDER FOR THE SUPPLY OF METAL MOULD ASSEMBLY FOR CONVEYOR TYPE ELECTRONIC TESTING MACHINE (10 STATION ET MACHINE)	
PLANT: PFT	REF: IFB No.HLL/CED/PFT/CET-BO/METAL MOULD /2016	DATE :08.08.2016

consequence of such inspection, if necessary, the Supplier shall arrange re-work at his own cost. Notwithstanding any such inspection/tests carried out at Supplier's works, the equipment shall be accepted only after receipt and successful commissioning at the site and the inspection/tests carried out at Supplier's works will not relieve his contractual obligations for conforming to the specifications under the Order.

#### **9. Performance Guarantee**

The Supplier shall fully guarantee all of the equipment supplied to perform in accordance with the specifications and to be free of all defects in design, material and workmanship. Should any equipment not performing as intended or should the design, material or workmanship prove defective within a period of 12 months from the date of successful commissioning, the equipment shall, upon notification of deficiency or defect, be promptly corrected by the Supplier to the satisfaction of Purchaser without delay and at no extra cost. If the Supplier fails to take proper corrective action to replace or repair the deficiency within a reasonable time of Purchaser's notification to this effect, the Purchaser shall be free to take such corrective action at the Supplier's risk and cost.

#### **10. Scope of Services, Supplies and Materials:**

The scope will include all services, supplies etc. for the satisfactory execution of the Contract except in so far as any of those are expressly excluded.

#### **11. Force Majeure**

- a. Neither the Supplier nor the Purchaser shall be considered in default in the performance of their obligations as per the Contract so long as such performance is prevented or delayed because of strikes, war, hostilities, revolution, civil commotion, epidemics, accidents, fire, cyclone, flood or because of any law and order proclamation, regulation or ordinance of Government or subdivision thereof or because of any act of God. The proof of existence of force majeure shall be provided by the party claiming it to the satisfaction of the other.
- b. The Supplier shall advise Purchaser initially by a Fax, followed by post, the beginning and end of any of the above causes of delay, failing which Purchaser shall not be liable to consider delays due to the above reasons. Notice as stated above should be given even in case where only the Supplier's bids are under the consideration of the Purchaser and no acceptance of the same has been given and detailed order issued.
- c. In the event of definite delay even if arising out of reasons due to force majeure, Purchaser shall have the right at their discretion to cancel the Order or part of the Order without any liability on their part to make any payment to the Supplier while reserving the right to claim refund of and any payment if advanced or paid to Supplier.

	<b>HLL LIFECARE LIMITED</b> <b>(A Government of India Enterprise)</b> <b>CENTRAL ENGINEERING DIVISION</b> <b>PEROOKADA PO, THIRUVANANTHAPURAM-</b> <b>695 005, KERALA, INDIA</b> <b>Phn: 0471 – 2437270, 2433374</b>	
	TENDER FOR THE SUPPLY OF METAL MOULD ASSEMBLY FOR CONVEYOR TYPE ELECTRONIC TESTING MACHINE (10 STATION ET MACHINE)	
PLANT: PFT	REF: IFB No.HLL/CED/PFT/CET-BO/METAL MOULD /2016	DATE :08.08.2016

## 12. Assignment And Subletting

No assignment and subletting of whole or part of the order shall be permitted except with prior approval of purchase obtained in writing.

## 13. Correspondence

All correspondence relating to this enquiry shall be in English, to:

**Deputy Chief Engineer (CED),**  
HLL Lifecare Limited  
Central Engineering Division,  
Perookada. PO, Thiruvananthapuram – 695005,  
Kerala, India  
Phn: 0471 – 2437270, 2433374  
E-mail: [rajeevrv@lifecarehll.com](mailto:rajeevrv@lifecarehll.com), [krknair@lifecarehll.com](mailto:krknair@lifecarehll.com)

## 14. Indemnification Clause

The Supplier shall indemnify and hold harmless the Purchaser from and against all claims, liability, loss damage or expense, including counsel fees arising from or by reason of any actual or claimed trade mark, patent or copy right infringement or any litigation based thereon with respect to any part of the items covered by the Contract, and such obligations shall survive acceptance of payment for the items.

## 15. Entirety of the Agreement

All of the terms agreed to between the Supplier and Purchaser will be included in the Purchase/work Order/Contract and no their communication, proposal or understanding, written, oral or implied, will be considered to be included in the Purchase/work Order/Contract or form part of the Contract between the Supplier and Purchaser unless specifically agreed to in that behalf in writing between Purchaser and Supplier.

## 16. Settlement Of Disputes

Arbitration shall not be a means of settlement of any dispute or claim arising out of the contract relating to the work. Any disputes or difference arising between the parties with respect to the performance of any part of this agreement or any thing connected therewith, etc shall as far as possible be mutually settled by the process of dialog and negotiation.

The Courts at Thiruvananthapuram alone shall have jurisdiction in respect of settlement of any matter arising out or in connection with the contract.

	<b>HLL LIFECARE LIMITED</b> <b>(A Government of India Enterprise)</b> <b>CENTRAL ENGINEERING DIVISION</b> <b>PEROOKADA PO, THIRUVANANTHAPURAM-</b> <b>695 005, KERALA, INDIA</b> <b>Phn: 0471 – 2437270, 2433374</b>	
	TENDER FOR THE SUPPLY OF METAL MOULD ASSEMBLY FOR CONVEYOR TYPE ELECTRONIC TESTING MACHINE (10 STATION ET MACHINE)	
PLANT: PFT	REF: IFB No.HLL/CED/PFT/CET-BO/METAL MOULD /2016	DATE :08.08.2016

**SCHEDULE IV**

Sub :	Supply & installation and alignment of Metal Mould Assembly as per Drawing No. HLL-CED-D2 074-00, HLL-CED-D2-079-00, HLL-CED-D2-080-00, HLL-CED-D2-081-00, HLL-CED-D2-082-00, HLL-CED-D2-084-00, HLL-CED-D2-086-00, HLL-CED-D2-086-00				
Sl. No	Item/Work Short Description	Quantity	Unit	Rate in Rs	Amount in Rs
I	Supply & installation and alignment of Metal Mould Assembly as per Drawing No. HLL-CED-D2 074-00, HLL-CED-D2-079-00, HLL-CED-D2-080-00, HLL-CED-D2-081-00, HLL-CED-D2-082-00, HLL-CED-D2-084-00, HLL-CED-D2-086-00, HLL-CED-D2-086-00	750.00	No		
<b>AMOUNT IN RS (EX WORKS)</b>					
EXCISE & OTHER DUTIES					
PACKING & FORWARDING CHARGES					
SALES TAX & OTHER TAXES, IF ANY					
ENTRY TAX, OCTROI AND OTHER LEVIES, IF ANY					
FREIGHT CHARGES INCLUDING TRANSIT INSURANCE					
<b>SUPPLY PRICE F.O.R HLL SITE, PEROORKADA, TRIVANDRUM</b>					
<b>(RUPEES IN WORDS)</b>					
I hereby agree to supply/execute the item/work specified at the above quoted rate/amount.					
<b>SUPPLIER/CONTRACTOR</b>					



	<b>HLL LIFECARE LIMITED</b> <b>(A Government of India Enterprise)</b> <b>CENTRAL ENGINEERING DIVISION</b> <b>PEROOKADA PO, THIRUVANANTHAPURAM-</b> <b>695 005, KERALA, INDIA</b> <b>Phn: 0471 – 2437270, 2433374</b>	
	<b>TENDER FOR THE SUPPLY OF METAL MOULD ASSEMBLY FOR CONVEYOR TYPE ELECTRONIC TESTING MACHINE (10 STATION ET MACHINE)</b>	
<b>PLANT: PFT</b>	<b>REF: IFB No.HLL/CED/PFT/CET-BO/METAL MOULD /2016</b>	<b>DATE :08.08.2016</b>

**SPLIT-UP RATE FOR EACH COMPONENT**

Sub :	Supply & installation and alignment of Metal Mould Assembly as per Drawing No. HLL-CED-D2-074-00, HLL-CED-D2-079-00, HLL-CED-D2-080-00, HLL-CED-D2-081-00, HLL-CED-D2-082-00, HLL-CED-D2-084-00, HLL-CED-D2-086-00, HLL-CED-D2-086-00				
Sl. No	Item/Work Short Description	Quantity	Unit	Rate in Rs	Amount in Rs
1	Metal Mould	750.00	No		
2	Sleeve	750.00	No		
3	Shaft	750.00	No		
4	Top cap	750.00	No		
5	Bottom cap	750.00	No		
6	T-Bush	750.00	No		
7	Plane washer	750.00	No		
8	Bush	750.00	No		
<b>AMOUNT IN RS (EX WORKS)</b>					
<b>EXCISE &amp; OTHER DUTIES</b>					

	<b>HLL LIFECARE LIMITED</b> <b>(A Government of India Enterprise)</b> <b>CENTRAL ENGINEERING DIVISION</b> <b>PEROOKADA PO, THIRUVANANTHAPURAM-</b> <b>695 005, KERALA, INDIA</b> <b>Phn: 0471 – 2437270, 2433374</b>	
	TENDER FOR THE SUPPLY OF METAL MOULD ASSEMBLY FOR CONVEYOR TYPE ELECTRONIC TESTING MACHINE (10 STATION ET MACHINE)	
PLANT: PFT	REF: IFB No.HLL/CED/PFT/CET-BO/METAL MOULD /2016	DATE :08.08.2016

PACKING & FORWARDING CHARGES	
SALES TAX & OTHER TAXES, IF ANY	
ENTRY TAX, OCTROI AND OTHER LEVIES, IF ANY	
FREIGHT CHARGES INCLUDING TRANSIT INSURANCE	
<b>SUPPLY PRICE F.O.R HLL SITE, PEROORKADA, TRIVANDRUM</b>	
<p><b>(RUPEES IN WORDS)</b></p> <p>I hereby agree to supply/execute the item/work specified at the above quoted rate/amount.</p> <p style="text-align: right;"><b>SUPPLIER/CONTRACTOR</b></p>	

	<b>HLL LIFECARE LIMITED</b> <b>(A Government of India Enterprise)</b> <b>CENTRAL ENGINEERING DIVISION</b> <b>PEROOKADA PO, THIRUVANANTHAPURAM-</b> <b>695 005, KERALA, INDIA</b> <b>Phn: 0471 – 2437270, 2433374</b>	
	TENDER FOR THE SUPPLY OF METAL MOULD ASSEMBLY FOR CONVEYOR TYPE ELECTRONIC TESTING MACHINE (10 STATION ET MACHINE)	
PLANT: PFT	REF: IFB No.HLL/CED/PFT/CET-BO/METAL MOULD /2016	DATE :08.08.2016

### SCHEDULE V

### ACCEPTANCE FORM

*(To be submitted in the letter head of the firm indicating full name and address, telephone & fax numbers etc.)*

From

To

**Deputy Chief Engineer(CED),**  
HLL Lifecare Limited  
Central Engineering Division,  
Peroorkada. PO,  
Thiruvananthapuram – 695005,  
Kerala, India  
Phn: 0471 – 2437270, 2433374  
E-mail: rajeevrv@lifecarehll.com, krknair@lifecarehll.com

Dear Sir,

I / We, hereby offer to design/fabricate/supply/commission as detailed in schedule hereto or such portion thereof as you may specify in the acceptance of Bid at the price given in the price schedule and agree to hold this offer open till 90 days after the date of bid opening prescribed by the purchaser. I/We have understood the terms and conditions mentioned in the invitation for bid and Conditions of Contract furnished by you and have thoroughly examined the specifications in the bid document hereto and are fully aware of the nature of the scope of work required and my/our offer is to comply strictly in accordance with the requirement and the terms and conditions mentioned above.

Yours faithfully,

**SIGNATURE OF THE BIDDER**

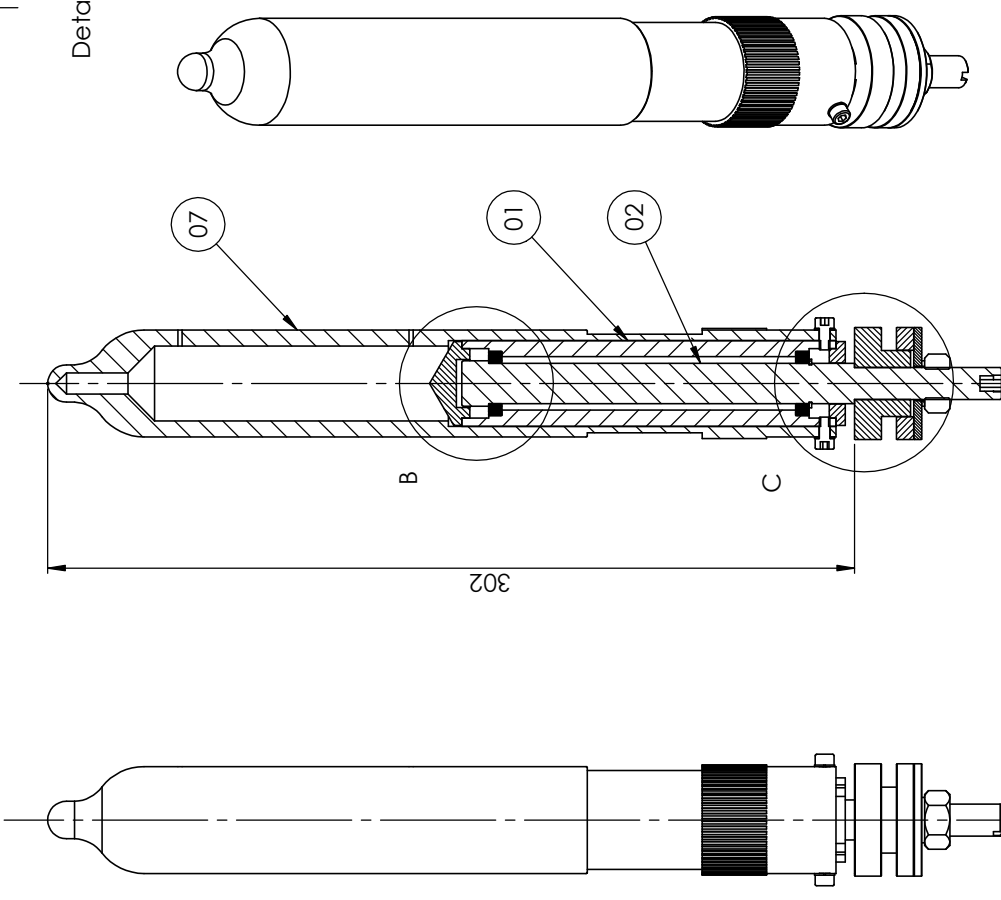
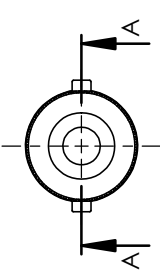

Detail - B

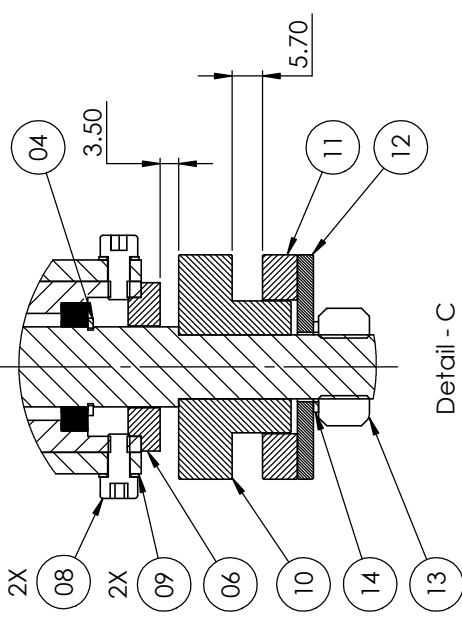

Detail - C

SI No	Description	Drawing No	Material	Qty	Scope of
01	Sleeve	HLL-CED-D2-081-00	EN 8	01 No	Party
02	Shaft - $\phi$ 15 mm	HLL-CED-D2-082-00	SS 304	01 No	Party
03	Deep Groove Ball Bearing ID 15 x OD 24 x W 5 mm (6802 2RS- Make : NMB Singapore)	Std Item	---	02 Nos	HLL Lifecare
04	External Circlip - Shaft $\phi$ 15 mm	Std Item	SS 304 Treated	01 No	HLL Lifecare
05	Top Cap	HLL-CED-D2-080-00	Nylon	01 No	Party
06	Bottom Cap	HLL-CED-D2-079-00	Nylon	01 No	Party
07	Metal Mold- $\phi$ 40 mm	HLL-CED-D2-086-00	MS	01 No	Party
08	M4 x 8 mm SHD Bolt	Std Item	SS 304	02 Nos	Party
09	M4 Spring Washer	Std Item	SS 304 Treated	02 Nos	HLL Lifecare
10	T-Bush	HLL-CED-D2-074-00	SS 304	01 No	Party
11	Bush	HLL-CED-D2-084-00	SS 304	01 No	Party
12	3 mm Plain Washer	HLL-CED-D2-083-00	SS 304	01 No	Party
13	M12 Hexagonal Nut	Std Item	SS 304	01 No	Party
14	M12 Spring Washer	Std Item	SS 304 Treated	01 No	HLL Lifecare

		<b>HLL LIFECARE LTD</b> <b>THIRUVANANTHAPURAM-5</b>		QTY 01 No
TITLE				
DRAWN BY		SARATH		
CHECKED BY		RAJKIRAN		
APPROVED BY		KRK		
DATE		04.06.2016		
SCALE		NTS		
ALL DIMENSIONS ARE IN MM				

<b>METAL MOLD ASSEMBLY</b>	
DRG NO:	HLL-CED-D2-085-00
SHEET NO :	01/02
REV:	DATE:

Section A-A Weight of the Assembly : 2.20 Kg (approx)

**Metal Mold Assembly with Conveyor Chain.**

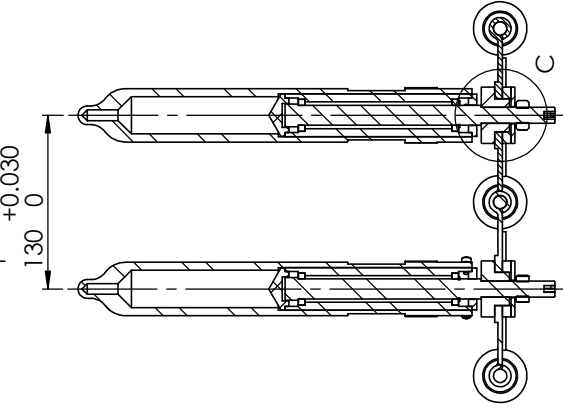
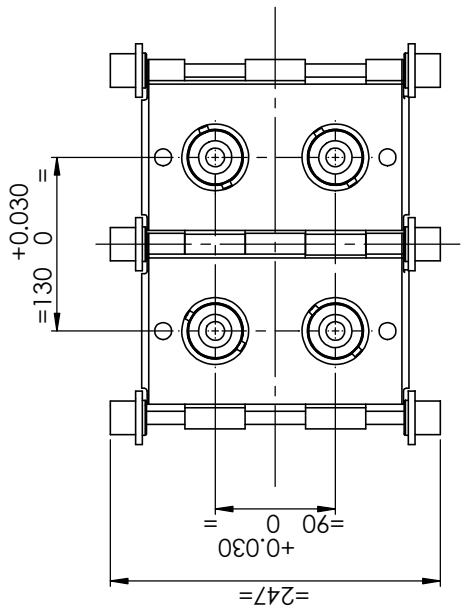

Section A-A

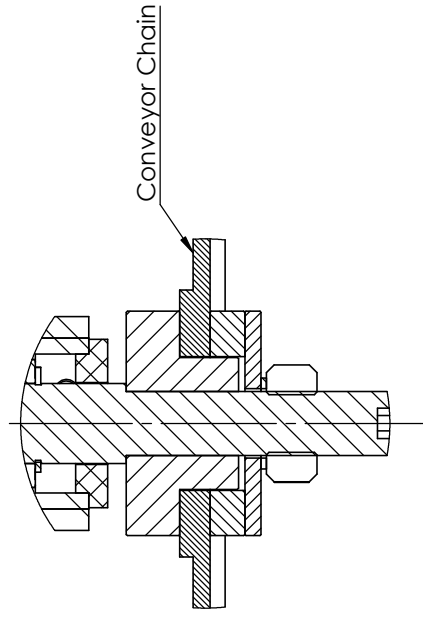
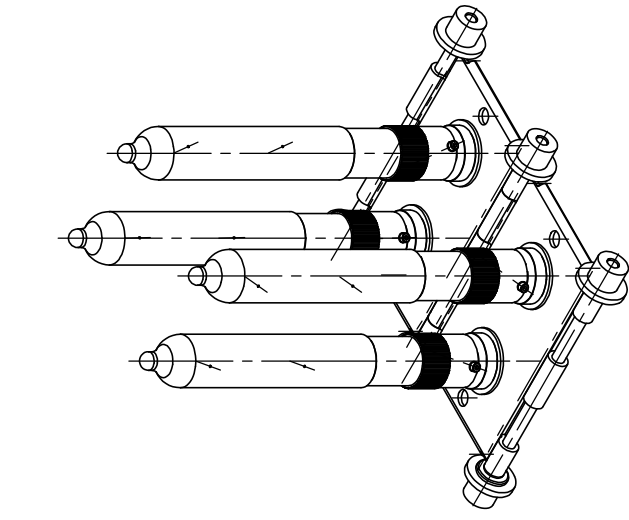
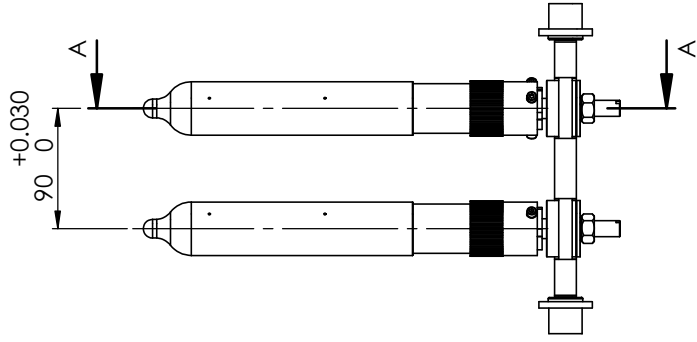

Detail - C

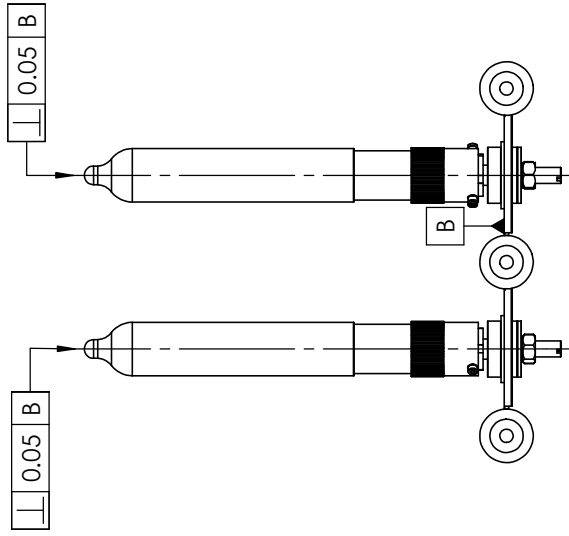

MATERIAL AS SPECIFIED	HLL LIFECARE LTD THIRUVANANTHAPURAM-5	QTY	01 No
DRAWN BY	SARATH	TITLE	METAL MOLD ASSEMBLY
CHECKED BY	RAJIRAN	DRG NO:	HLL-CED-D2-085-00
APPROVED BY	KRK	DATE	08.06.2016
SCALE	NITS	SHEET NO :	02/02
ALL DIMENSIONS ARE IN MM		REV	DATE

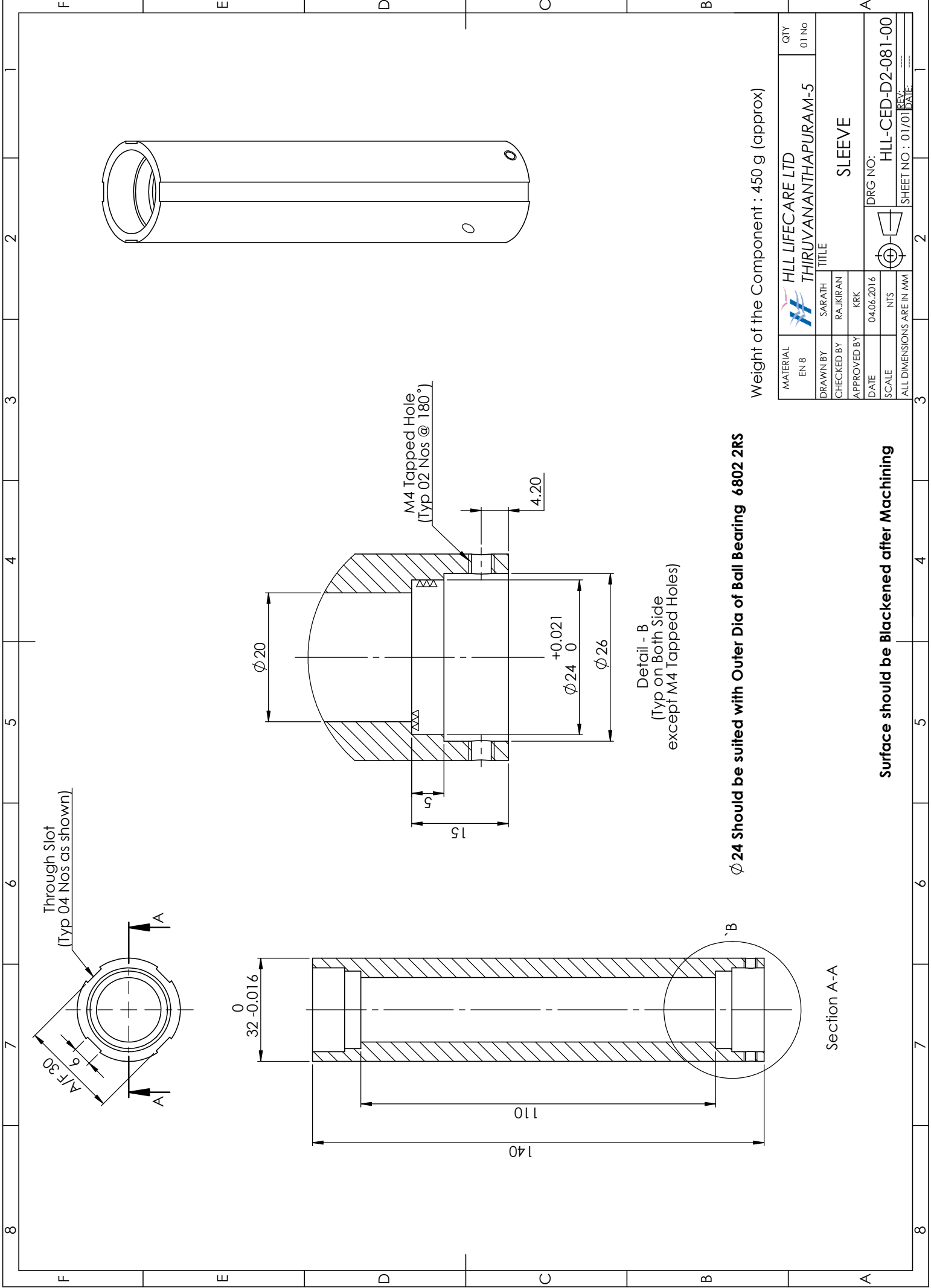

Weight of the Component : 450 g (approx)

MATERIAL EN 8	HILL LIFECARE LTD THIRUVANANTHAPURAM-5	QTY 01 No
DRAWN BY SARATH	TITLE SLEEVE	
CHECKED BY RAJIKIRAN		
APPROVED BY KRK		
DATE 04.06.2016		
SCALE NTS		
ALL DIMENSIONS ARE IN MM		
DRG NO: HILL-CED-D2-081-00		
SHEET NO : 01/01	REV. DATE	

$\phi 24$  Should be suited with Outer Dia of Ball Bearing 6802 2RS

Detail - B  
(Typ on Both Side  
except M4 Tapped Holes)

Surface should be Blackened after Machining

Section A-A

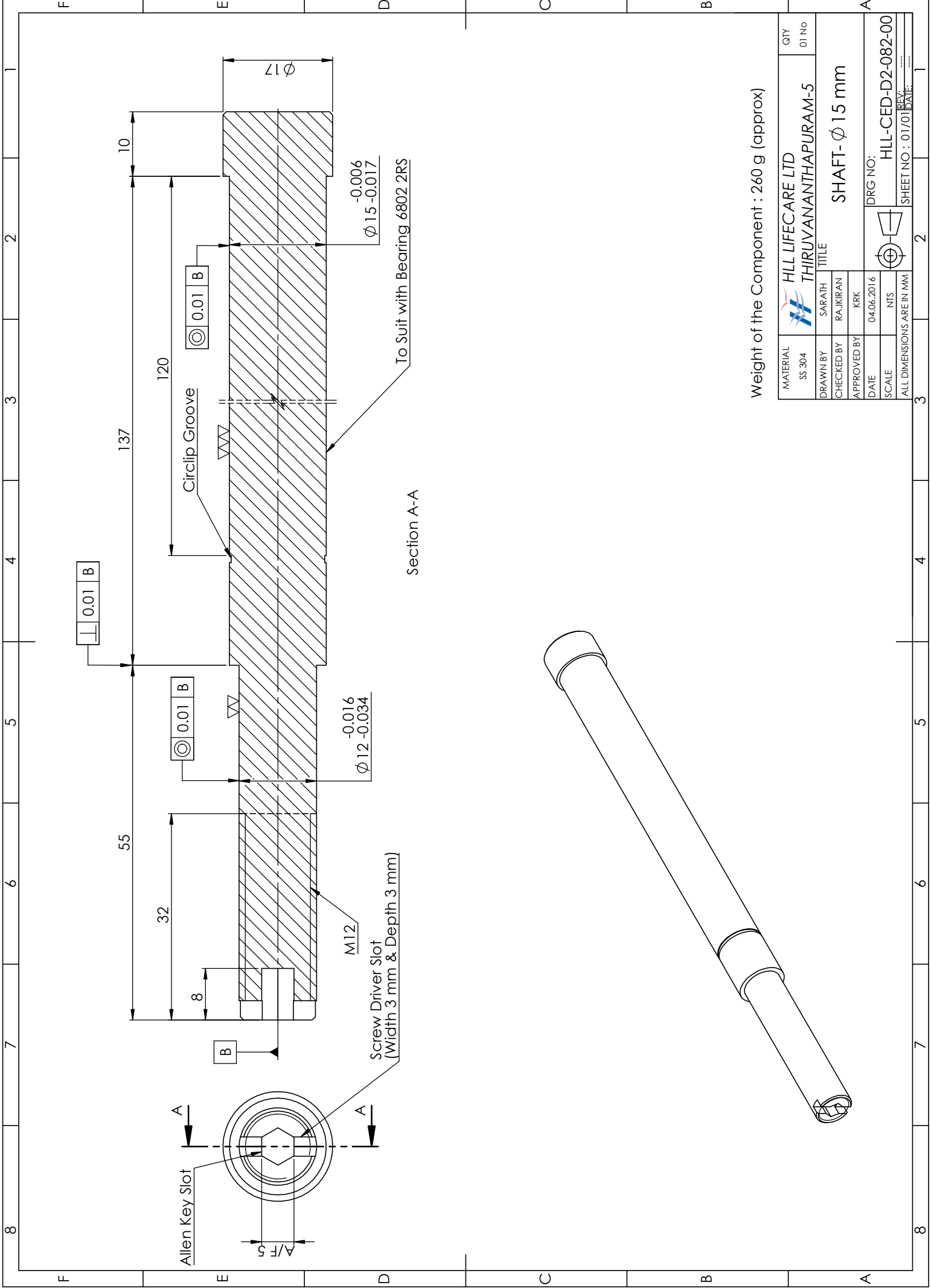

Weight of the Component : 260 g (approx)

MATERIAL	SS 304	HILL LIFECARE LTD	QTY	01 No
DRAWN BY	SARATH	THIRUVANANTHAPURAM-5		
CHECKED BY	RAJIRAN	TITLE	SHAFT- $\phi 15$ mm	
APPROVED BY	KRK			
DATE	04.06.2016			
SCALE	NIS			
ALL DIMENSIONS ARE IN MM		DRG NO:	HLL-CED-D2-082-00	
		REV:	DATE	

4

3

2

1

F

F

E

E

D

D

C

C

B

B

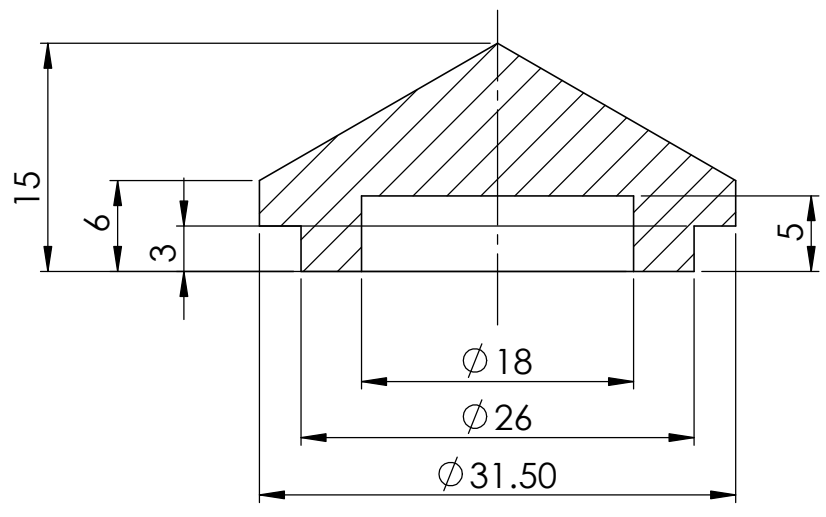
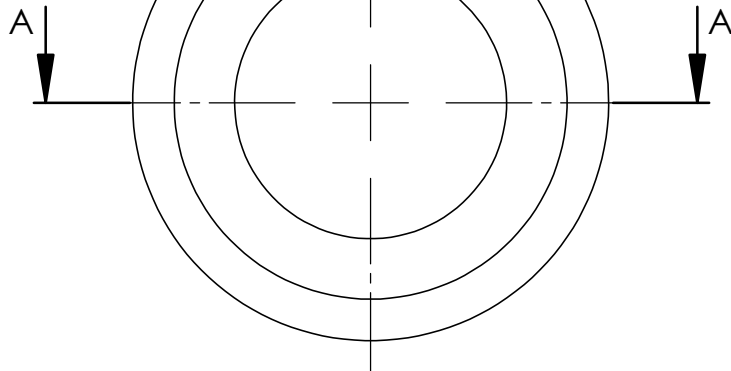

Section A-A

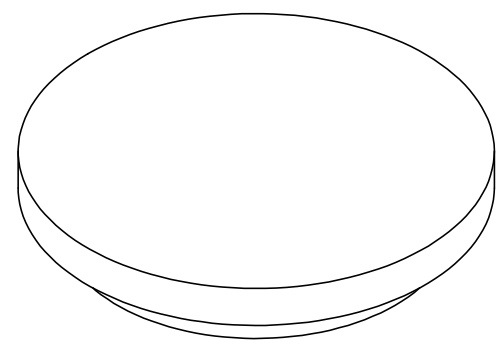

Weight of the Component : 7.0 g (approx)

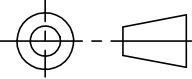
MATERIAL NYLON (BLACK COLOUR)		HLL LIFECARE LTD THIRUVANANTHAPURAM-5	QTY 01 No
DRAWN BY	SARATH	TITLE <b>TOP CAP</b>	
CHECKED BY	RAJKIRAN		
APPROVED BY	KRK		
DATE	03.06.2016	DRG NO:	HLL-CED-D2-080-00
SCALE	NTS	SHEET NO:	01/01
ALL DIMENSIONS ARE IN MM			REV: DATE:

4

3

2

1

A

A



4

3

2

1

F

F

E

E

D

D

C

C

B

B

A

A

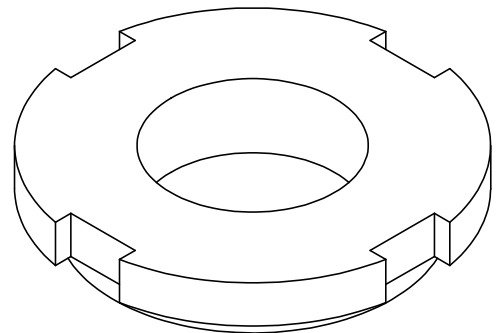
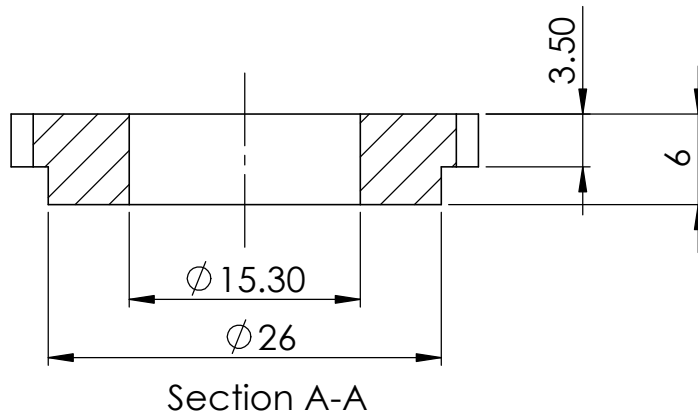
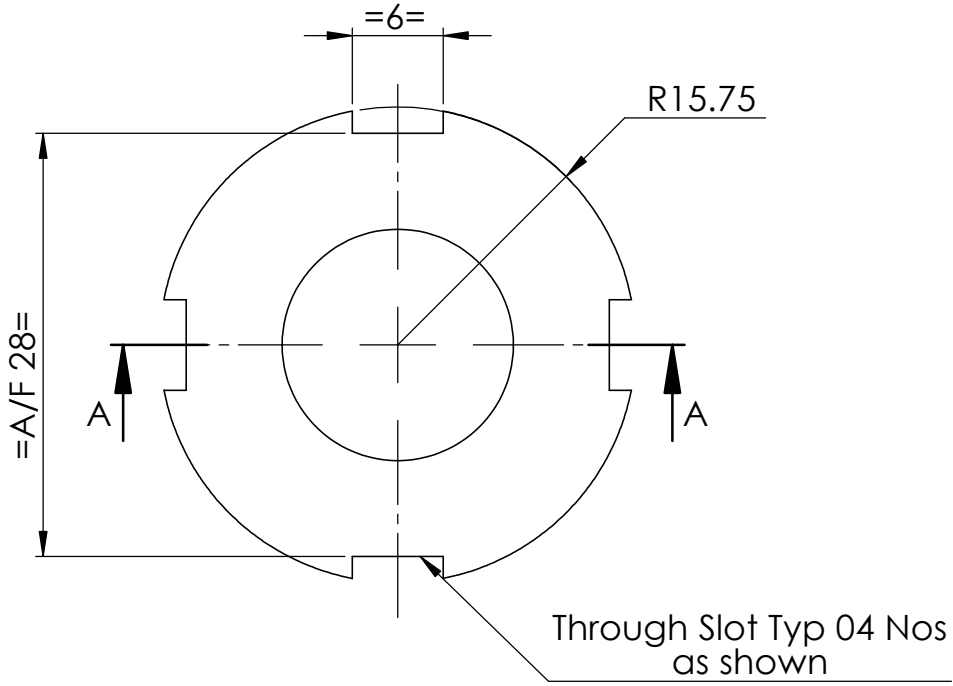

Weight of the Component : 4.0 g (approx)

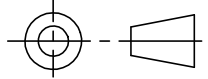
MATERIAL NYLON (COLOUR : BLCK)		HLL LIFECARE LTD THIRUVANANTHAPURAM-5	QTY 01 No
DRAWN BY	SARATH	TITLE <b>BOTTOM CAP</b>	
CHECKED BY	RAJKIRAN		
APPROVED BY	KRK		
DATE	03.06.2016	DRG NO:	HLL-CED-D2-079-00
SCALE	NTS	SHEET NO:	01/01
ALL DIMENSIONS ARE IN MM			REV: DATE:

4

3

2

1

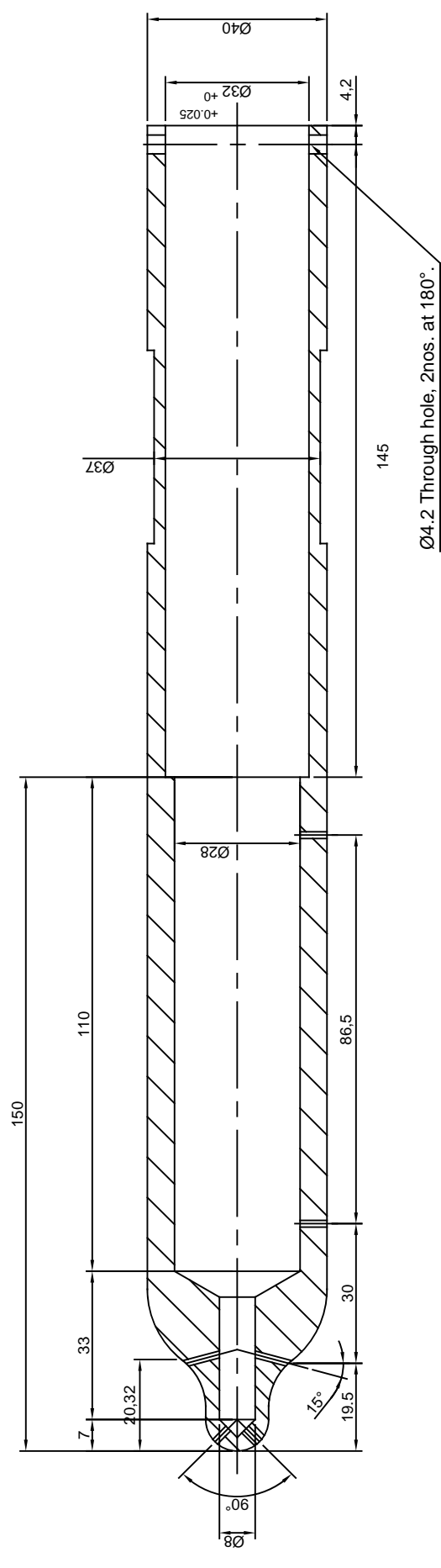
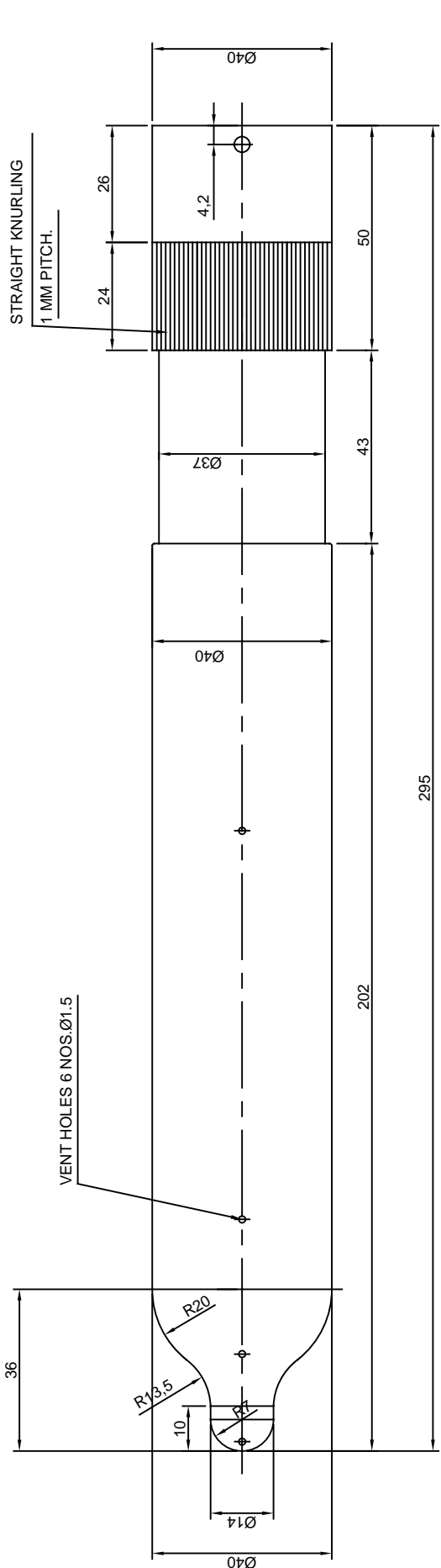

MATERIAL: MS,Hard chromium plating 0.02 +0	<b>HLL LIFECARE LIMITED.</b> <b>THIRUVANANTHAPURAM-5</b>	NO.OFF: 01 No
DRAWN BY: SARATH	TITLE:- METAL MOLD - Ø40 mm	
CHECKED BY: RAJKIRAN		
APPROVED BY: KRR		
DATE: 07.06.2016		
SCALE: NTS		
ALL DIMENSIONS ARE IN M.M		
		Drg no.: HLL-CED-D2-086-00 REV: --- Date: ---

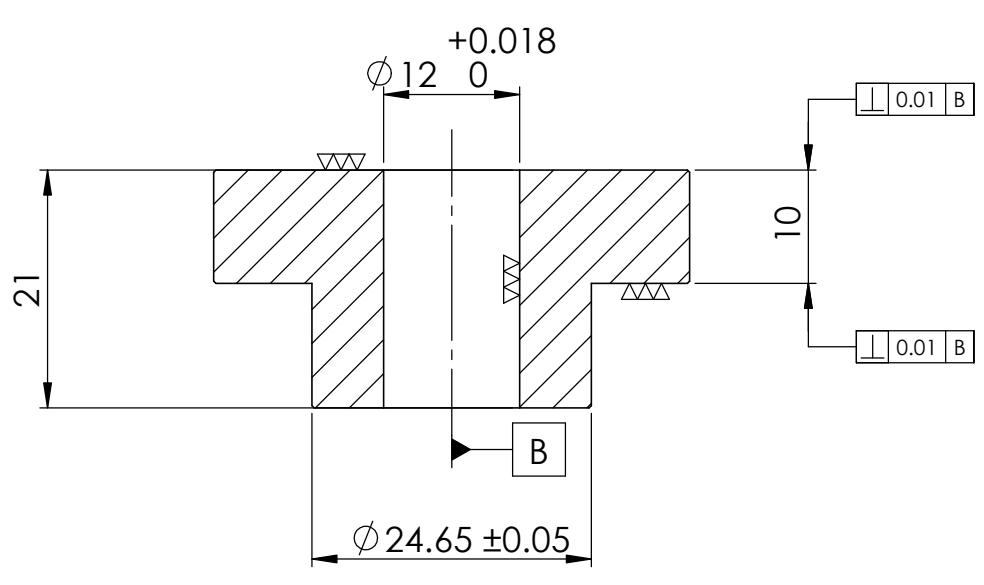
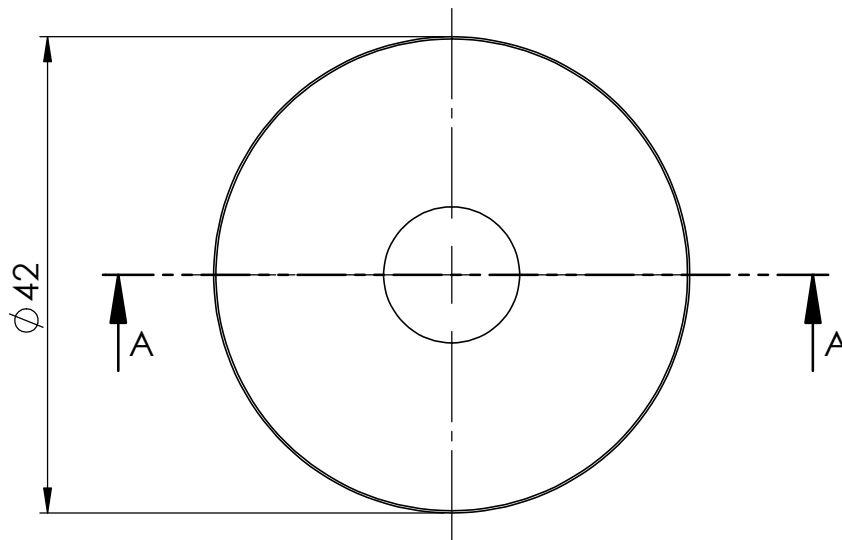

Section A-A

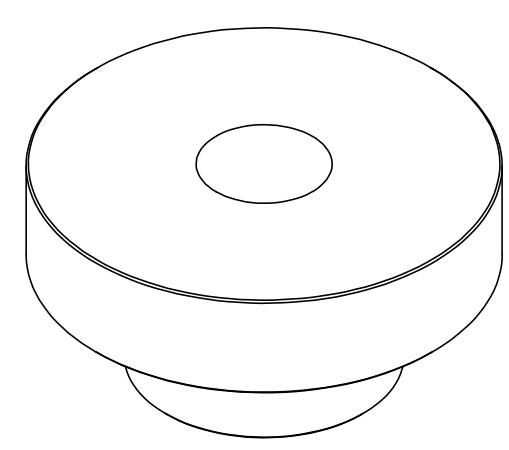

Weight of the Component : 133 g (approx)

Surface Finish :  $\nabla\nabla$  ( $\nabla\nabla\nabla$ )

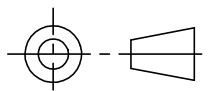
MATERIAL SS 304	 <b>HLL LIFECARE LTD</b> <b>THIRUVANANTHAPURAM-5</b>	QTY 01 No
DRAWN BY SARATH		<b>T-BUSH</b>
CHECKED BY RAJKIRAN		
APPROVED BY KRK		
DATE 03.05.2016		DRG NO: <b>HLL-CED-D2-074-00</b>
SCALE NTS		SHEET NO: 01/01
ALL DIMENSIONS ARE IN MM		

4

3

2

1

F

F

E

E

D

D

C

C

B

B

A

A

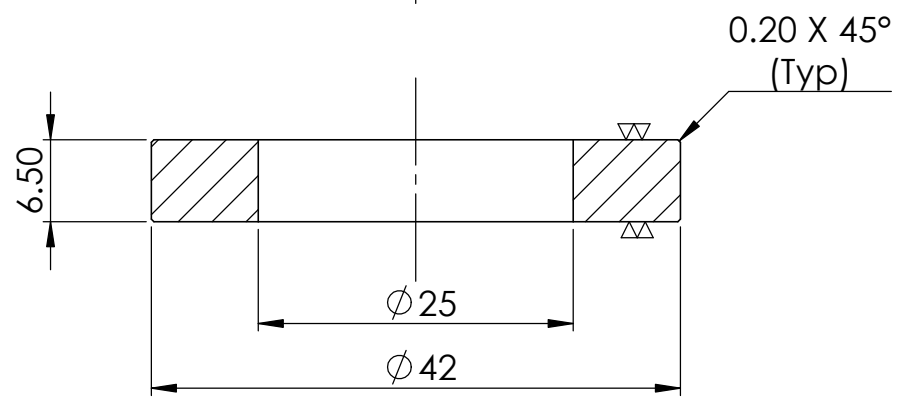
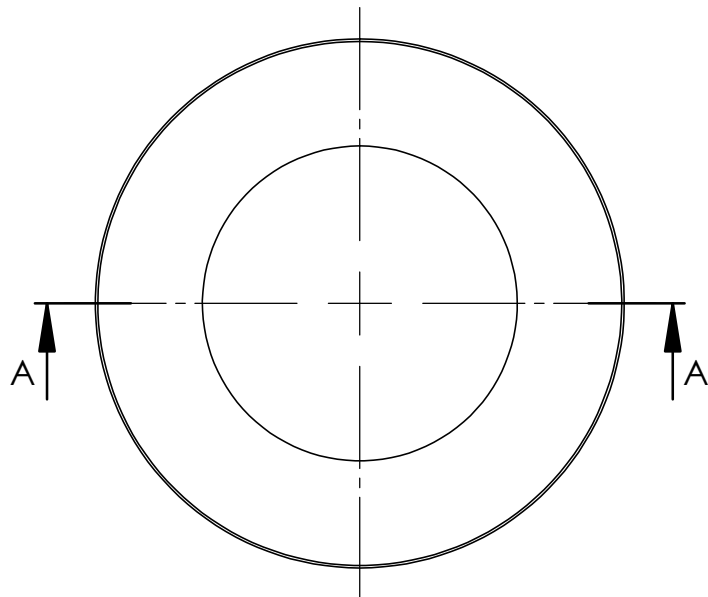

Section A-A

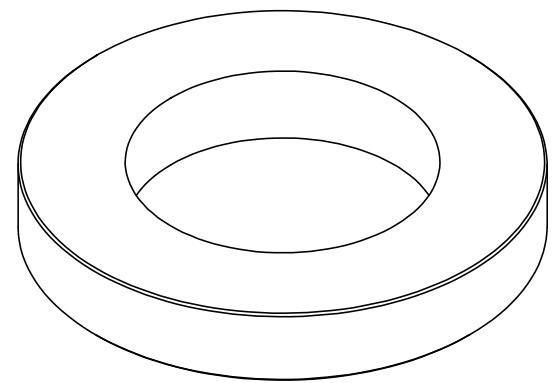

Weight of the Component : 46 g (approx)

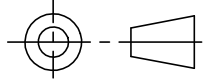
MATERIAL SS 304		HLL LIFECARE LTD THIRUVANANTHAPURAM-5	QTY 01 No
DRAWN BY SARATH	CHECKED BY RAJKIRAN	TITLE BUSH	
APPROVED BY KRK	DATE 04.06.2016	DRG NO: HLL-CED-D2-084-00	
SCALE NTS		SHEET NO: 01/01	REV: DATE:
ALL DIMENSIONS ARE IN MM			

4

3

2

1

4

3

2

1

F

F

E

E

D

D

C

C

B

B

A

A

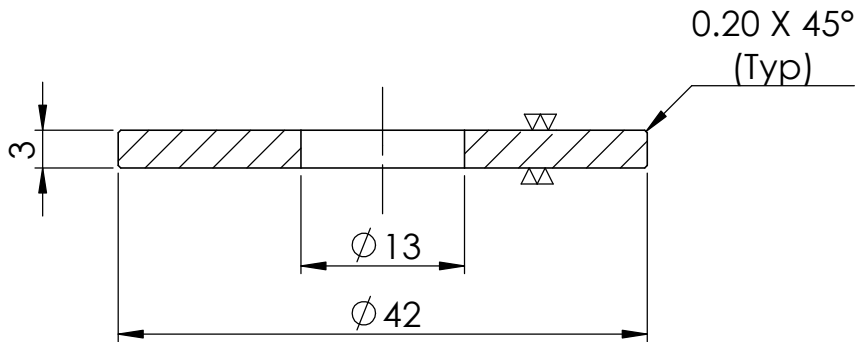
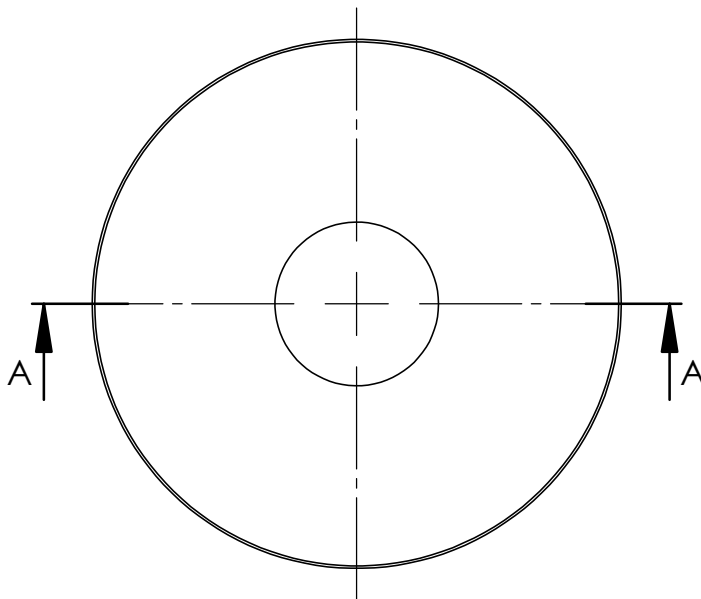

Section A-A

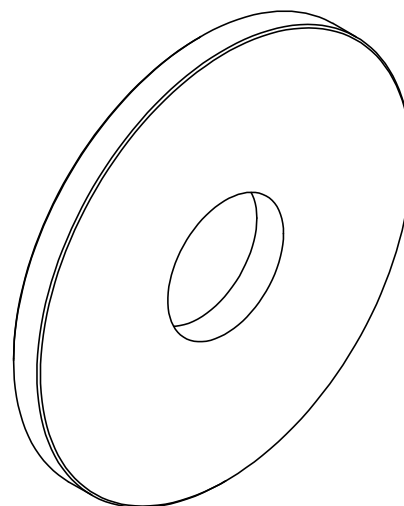

Weight of the Component : 30 g (approx)

MATERIAL SS 304		HLL LIFECARE LTD THIRUVANANTHAPURAM-5	QTY 01 No
DRAWN BY SARATH	CHECKED BY RAJKIRAN	TITLE 3mm PLAIN WASHER	DRG NO: HLL-CED-D2-083-00
APPROVED BY KRK	DATE 04.06.2016	SHEET NO: 01/01	
SCALE NTS	ALL DIMENSIONS ARE IN MM		REV:

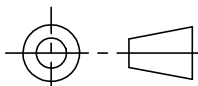

4

3

2

1