

**HLL LIFECARE LTD,
CENTRAL ENGINEERING DIVISION
PEROORKADA FACTORY,
THIRUVANANTHAPURAM – 695 005,
KERALA, INDIA.
PHN: ++91 471 2437270
FAX: ++91 471 2432647**

TENDER DOCUMENT

**SUPPLY OF DEHYDRATOR FOR THE BTADL
CONDOM DIPPING MACHINE
AT
HLL IRAPURAM FACTORY**

IFB No.: HLL/CED/CON-AUG/DEHYDRATOR/BTADL CDM/IFC/2014

DATE: 30-12-2014

HLL LIFECARE LIMITED
(A Government of India Enterprise)
Central Engineering Division, Peroorkada. P.O,
Thiruvananthapuram – 695005,
Kerala, India
Phn: 0471- 2433374,2437270, 2435090
Fax No. (0471) 2432647

INVITATION FOR BIDS (IFB)

IFB No.: HLL/CED/CON-AUG/DEHYDRATOR/BTADL CDM/IFC/2014
DATE: 30.12.2014

HLL Lifecare Limited (HLL) invites sealed and super scribed bids from competent and experienced eligible Suppliers/Contractors for the supply of following item in connection with the Augmentation of condom production at our factory in Irapuram,Kerala.

Sl. No	Brief Description of Item/Work	Quantity	EMD
1	Supply of dehydrator as per the drawing and specifications at our HLL, Irapuram Factory, Kerala	As per schedule of items	Rs 2500/-

SCHEDULE I

INSTRUCTION TO BIDDERS:

1. A complete set of bid documents can be had from the Office of the Associate Vice President (CED), Central Engineering Division, HLL Lifecare Limited, Peroorkada Factory, Thiruvananthapuram – 695 005, Kerala, India during office hours on any working day on submission of written application.

The Tender Documents can also be downloaded from our Website www.lifecarehll.com from the date of issue of tender document. Tender forms shall be filled in ink or typed. No tender filled in pencil shall be considered. The tenderer shall sign and seal the form at each page and at the end, in token of acceptance of all the terms and conditions of the tender. Any subsequent changes/amendments will be published only in our website.

2. The scheduled date for issue, receipt and opening of bids is as follows.

- a) Date of issue of tender document - 30.12.2014
- b) Last date and time for receipt of bids - 06.01.2015 up to 15.00 Hrs.
- c) Date and time of opening of bids - 06.01.2015, 15.30 Hrs.
- d) Address for communication, receipt and place of opening of bids:

Associate Vice President (CED)
Central Engineering Division,
HLL Lifecare Limited (A Government of India Enterprise),
PB No 2, Peroorkada, Thiruvananthapuram – 695005,
Kerala State, India
Ph: (++91 471) 2433374,2437270 –501,502
Tele Fax: (++ 91 471) 2432647
E-mail: srnair@lifecarehll.com, rajeevrv@lifecarehll.com

3. The Bid must include the following information;

- a. Enquiry No.
- b. EMD
- c. Promised Delivery Schedule for each item.
- d. Acceptance Form (Schedule III)
- e. Price Schedule in Format For Quoting (Schedule IV)
- f. All other documents/certificate/information as specified in the bid document.

4. Each bid must be accompanied by E.M.D. The EMD shall be in the form of Demand Draft from a nationalized bank drawn in favour of HLL LIFECARE LTD, Thiruvananthapuram payable at Thiruvananthapuram. E.M.D. of the unsuccessful bidders will be released after evaluating tenders, keeping only the earnest money of the first three lowest bidders. The earnest money deposit of the remaining two unsuccessful bidders will be released after the acceptance of the notification of award by the successful bidder. The EMD may be forfeited, if a Bidder withdraws his bid during the period of bid validity specified by the Bidder on the Bid Document.

5. SSI units interested in availing exemption from payment of EMD should submit a valid copy of their registration certificate issued by the concerned DIC or NSIC.

6. In addition to the invitation for bids, the bidding documents include the following schedules.

Schedule I	- Instruction to the Bidders
Schedule II	- Conditions of Contract
Schedule III	- Specifications
Schedule IV	- Acceptance Form
Schedule V	- Format for quoting

7. The completed and sealed bid documents should be submitted to Associate Vice President (CED), in the above address. The outer cover should bear the Enquiry No, closing date and General description of item tendered, and the words "DO NOT OPEN BEFORE" 15.30 Hrs (IST) on ----- (Indicate the Closing Date).

8. Bids will be opened in the presence of bidders' representative(s) who choose to attend on the specified date and time, at the office of HLL at the address given in Clause 2 (d) above.

9. In the event of the date specified for bid receipt and opening being declared as a closed holiday for purchaser's office, the due date for submission of bids and opening of bids will be the following working day at the appointed times.

10. The purchaser may, at its discretion, extend this deadline for submission of bids by amending the Bid Documents or any other reasons, in which case all rights and obligations of the Purchaser and Bidders previously subject to the deadline will thereafter be subject to the deadline as extended.

11. Purchaser will not be held responsible for the postal delay, if any, in the delivery of the bidding document or the non-receipt of the same. Bids sent by Telex/Fax/Telegraph will not be accepted.

12. HLL reserves the right to club or split the items of works, change the qualifying criteria at their discretion and to reject or cancel the Invitation for bids without assigning any reason thereof.

ASSOCIATE VICE PRESIDENT (CED)

SCHEDULE II

CONDITIONS OF CONTRACT

1) PRICE

The price quoted should be inclusive of Basic Price, all applicable taxes and duties including VAT, Entry tax, Octroi & other levies, P&F charges, loading and unloading charges, insurance, etc. The Supplier should pay entry taxes, as applicable and should be included in the offer.

The Format for Quoting (Schedule IV) shall be suitably filled as applicable. The quoted rate shall be valid for a period of 31st March 2015. No price escalation and no change in terms and conditions will be allowed on any ground till the order is completely executed.

2) TAXES/DUTIES/LEVIES

The supplier shall be entirely responsible for all taxes including entry tax, duties, license fees, etc. incurred until successful completion of contract. All central, state, municipal taxes, duties and levies payable shall be shown by the bidder separately in the Bid. The Purchaser will issue necessary 'C' Form, if required.

3) COMPLETION TIME

- a. The item should be delivered within 30 days from the date of issuing the Letter of Intent or Supply Order.
- b. The quantity mentioned herein are approximate requirement with staggered delivery.
- c. In case less or more quantity is required the suppliers should be prepared to effect supply at short notice on the same terms and conditions.

4) GUARANTEE PERIOD

The Guarantee against any possible manufacturing defects shall be given for a period of 18 months from the date of supply and inspection of the item at HLL site or 12 months from the date of supply, whichever is earlier.

5) DELIVERY ADDRESS

HLL LIFECARE LIMITED
(A Government of India Enterprise)
Plot No.1, Rubber Park,
Irapuram Village,
Valayanchirangara P.O
Kunnathunadu Taluk,
Ernakulam (District)
PIN-683541,

Kerala, India
Phn: 0484-2257020
E-mail: rajeevrv@lifecarehll.com

6) LIQUIDATED DAMAGES FOR DELAYS

If the material is not supplied to the purchaser within the time stipulated in the Order, Purchaser may at their option, either (1) recover from the Supplier liquidated damages at the rate of 0.5 % of the total purchase order value for every week of delay, subject to a maximum of 7.5 % of the total purchase order value, or (2) at the risk and cost of the Supplier and without prejudice to the other remedies/rights as per the Contract, terminate the order wholly or partially and complete it themselves or reassign it to other Suppliers.

7) PAYMENT TERMS

- a) 60% of the total supply price will be paid against supply, inspection and acceptance of the items at HLL, Irapuram site,
- b) Balance 20% of the total supply order price will be released after successful installation and trial run of the system.
- c) The balance 10% payment shall be released against a Performance guarantee valid for a period of one year from the date of the issue of final acceptance certificate of the entire system.

7. SETTLEMENT OF DISPUTES

Any disputes or differences or questions or claims arising under or relating to or touching this agreement shall be referred for arbitration to a Sole Arbitrator under the provisions of the Arbitration and Conciliation Act 1996 or any statutory modification or re-enactment thereof for the time be in force. The award passed by the arbitrator shall be final and binding on the parties hereto.

The contract shall be deemed to have been concluded at Thiruvananthapuram, Kerala and suits and proceedings, if any, shall be only in the courts of competent jurisdiction in Thiruvananthapuram.

The venue of arbitration shall be the place from where the contract is issued.

The company reserves the right to club or split the items of supply and reject or cancel the Invitation for bids without assigning any reason thereof.

SCHEDULE III

SPECIFICATIONS

Part - A

Requirement

HLL require On Line powder finishing operation system of quantity 2 nos (1 Set each) for two Butterfly Type Automatic Double Line Condom Dipping Machine at our factory in Irapuram,Kerala .

Specifications

Item: As per drawing no.

- 1 Drg .no:- HLL-CED-C2-011-00 (De-hydrator parts)
2. Drg.no:- HLL-CED-C2-011-00 (Dehydrator assembly)
3. Drg.no:- HLL-CED-C2-011-00 (Dehydrator parts list)
4. Drg.no:- HLL-CED-C2-011-01 (Circulation Tank)

Powder finishing product:

Natural Rubber Latex Male Contraceptive Condoms as per ISO 4074.

DETAILS

1. **HYDRO EXTRACTION:** AFTER POWDER FINISHING THE WET CONDOMS WILL PASS THROUGH A DEHYDRATOR HAVING DIRECT DRIVEN MOTORISED GEARBOX (SCOPE OF HLL) HOLLOW SHAFT ABLE TO ROTATING DE HYDRATOR AT A SPECIFIED SPEED. THIS WILL CATER THE EXACT NEEDS OF THE HYDROEXTRACTION AND PARTIAL DRYING PROCESSES. THE ROTATING DRUM AS PER DRAWING. IS TO BE STATICALLY BALANCED AT THE SPECIFIED SPEED OF 25 RPM
2. **HOT AIR FLOW:** A PRE- HEATER OF ELECTRICALLY OPERATED PROVIDED ON THE TOP OF THE DEHYDRATOR TO DRY THE CONDOMS FOR TRANPORTATION TO TUMBLER. THIS IS TO FACILITATE THE PRE-

VULCANISING OF CONDOMS. (SUPPLY OF PRE-HEATER IS UNDER HLL SCOPE).

3. **SAFETY REQUIREMENT:** NOISE LEVEL SHOULD BE 75 DB WHILE IN OPERATION.
4. **ENGINEERING REQUIREMENT:**
 - DESIGN OF EQUIPMENT SHOULD ENHANCE CLEANING FEASIBILITY BY PROVIDING NO SHARP CORNERS, MINIMUM CREVICES & SMOOTH FINISHED WELD JOINTS.
 - THE MATERIAL USED FOR THE DE HYDRATOR DRUM AND MESH SHOULD BE CONSTRUCTED OF 316L GRADE STAINLESS STEEL WITH BUFFED QUALITY SURFACE FINISH $< 0.5\mu\text{M}$ Ra CONDOMS SHOULD NOT BE DAMAGED WHILE PASSING THROUGH THE DEDYDRATOR.
 - GASKETS, SEALS & O –RINGS COMING IN DIRECT/INDIRECT CONTACT SURFACES SHOULD BE CONSTRUCTED OF WHO APPROVED FOOD GRADE MATERIALS ONLY.
 - ALL MATERIAL SHOULD HAVE TEST CERTIFICATE.
 - EQUIPMENT SHOULD BE FABRICATED BY FOLLOWING ALL GOOD ENGINEERING PRACTICES.
 - SYSTEM SHALL BE INSPECTED & TESTED AT VENDORS SITE.
5. THE MATERIAL USED IN THE PATHS AND CONTACT PARTS SHOULD BE PERFECTLY IN CONFORMANCE TO ELIMINATE HANDLING DAMAGE TO THE NATURAL RUBBER PRODUCT AND AS PER WHO GMP STANDARDS.
6. ALL CONTROLLERS SHOULD BE SUITABLE FOR WITHSTANDING POWER FLUCTUATIONS AND WITH SOFT STARTING TECHNOLOGY. SUITABLE PANEL BOARD SHOULD BE PROVIDED AT REMOTE AREA COMPLYING ALL SAFETY NORMS.
7. NECESSARY PAINTING WORKS SUITABLE FOR DUSTY AND HOT ENVIRONMENT AS PER STANDARD NORMS.
8. STATIC ELECTRICITY DISCHARGERS SHOULD BE PROVIDED WHEREVER NECESSARY.
9. RATE SHOULD BE QUOTED SEPARATELY FOR SUPPLY AND SERVICE LIKE INTEGRATION, TESTING AND COMMISSIONING OF ONE SUCH

SYSTEM AS PER PRICE SCHEDULE .BILL OF MATERIALS SHOULD BE PROVIDED SEPARATELY IN SUPPORT TO THE SUPPLY.

- 10.COMMISSIONING: COMMISSIONING OF THE SYSTEM OR ANY PART THEREOF SHALL BE COMMENCED BY THE BIDDER IMMEDIATELY AFTER RECEIPT OF INTIMATION FROM HLL. HLL SHALL SUPPLY THE OPERATING PERSONNEL AND ALL RAW MATERIALS, UTILITIES, LUBRICANTS, CHEMICALS SERVICES AND OTHER MATTERS REQUIRED FOR COMMISSIONING.
- 11.**PERFORMANCE TEST:** THE PERFORMANCE TEST SHALL BE CONDUCTED BY THE BIDDER DURING THE COMMISSIONING OF THE SYSTEM TO ASCERTAIN WHETHER THE SYSTEM CAN ATTAIN THE FUNCTIONAL GUARANTEES SPECIFIED IN THE TECHNICAL SPECIFICATION.
- 12.**OPERATIONAL ACCEPTANCE:** OPERATIONAL ACCEPTANCE SHALL OCCUR IN RESPECT OF THE SYSTEM WHEN THE PERFORMANCE TEST HAS BEEN SUCCESSFULLY COMPLETED AND THE FUNCTIONAL PERFORMANCES ARE MET.
- 13.PERIOD WARRANTY SHALL BE 12 MONTHS FROM THE DATE OF INSTALLATION AND COMMISSIONING AS CERTIFIED JOINTLY BY THE SUPPLIER AND THE PURCHASER.
- 14.THE BIDDER SHALL ATTEND THE PRE-BID CONFERENCE ARRANGED BY HLL BEFORE SUBMITTING THE OFFER.
15. THREE COPIES OF INSTRUCTION/OPERATIONAL MANUAL (ESPECIALLY FOR BROUGHT OUT ITEMS) AND MAINTENANCE MANUAL SHOULD BE SUPPLIED ALONG WITH THE MACHINE.
- 16.A LIST OF SPARE PARTS SHOULD BE PROVIDED. A MINIMUM SET OF SPARE PARTS SHOULD BE PROVIDED FOR EACH MACHINE.
- 17.BROUGHT OUT ITEMS SUCH AS ELECTRICAL/ELECTRONIC ITEMS, ELECTRIC HEAT BANKS ETC SHOULD BE AS PER RELEVANT INDIAN STANDARDS APPROVED CERTIFICATIONS.

SCHEDULE IV

ACCEPTANCE FORM

(To be submitted in the letter pad of the firm indicating full name and address, telephone & fax numbers etc.)

From

To

Associate Vice President (CED)
Central Engineering Division,
HLL Lifecare Limited (A Government of India Enterprise),
PB No 2, Peroorkada, Thiruvananthapuram – 695005,
Kerala State, India
Ph: (++91 471) 2433374,2437270 –501,502
Tele Fax: (++ 91 471) 2432647
E-mail: smair@lifecarehll.com, rajeevrv@lifecarehll.com

Dear Sir,

I / We, hereby offer to supply materials as detailed in schedule here to or such portion thereof as you may specify in the acceptance of Bid at the price given in the price bid and agree to hold this offer open till 90 days after the date of bid opening prescribed by the purchaser. I/We have understood the terms and conditions mentioned in the invitation for bid and Conditions of Contract furnished by you and have thoroughly examined the specifications and drawings in the bid document hereto and are fully aware of the nature of the scope of supply and my/our offer is to comply strictly in accordance with the requirement and the terms and conditions mentioned above. I/We have understood that the PURCHASER is the sole owner of the technology, equipment, specification and drawings given along with the bidding documents. I/we here by assure that the above information will be kept confidential and will not be used for any other purpose or will not be transferred to third party.

Yours faithfully,

SIGNATURE OF THE BIDDER

SCHEDULE V

SCHEDULE FOR SUPPLY OF DEHYDRATOR FOR THE BTADL CONDOM DIPPING MACHINE AT IRAPURAM

Sl.No.	Item description	Unit	Qty.	Rate/set	Amount
1.	Supply of dehydrator as per the specifications at our HLL, Irapuram Factory, Kerala	SET	2		
	Basic price in Rs.				
	Excise duty in Rs.				
	Cess on excise duty				
	CST/VAT (% to be furnished)				
	Freight				
	Insurance				
	Others, if any (please specify)				
	Total delivered rate at HLL				

(In words)

I agree to complete the SITC as per schedule at the rates quoted by me as above and the terms and conditions of the tender document.

SIGNATURE OF BIDDER

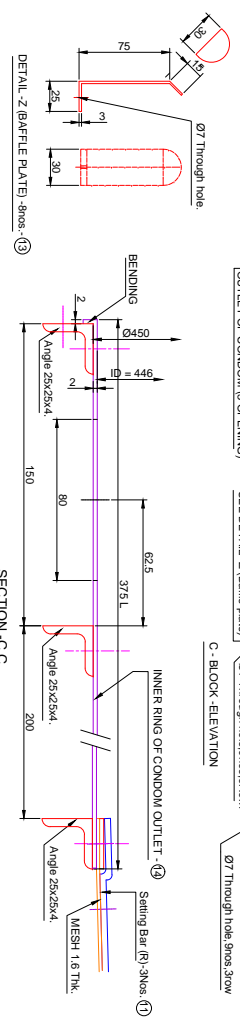
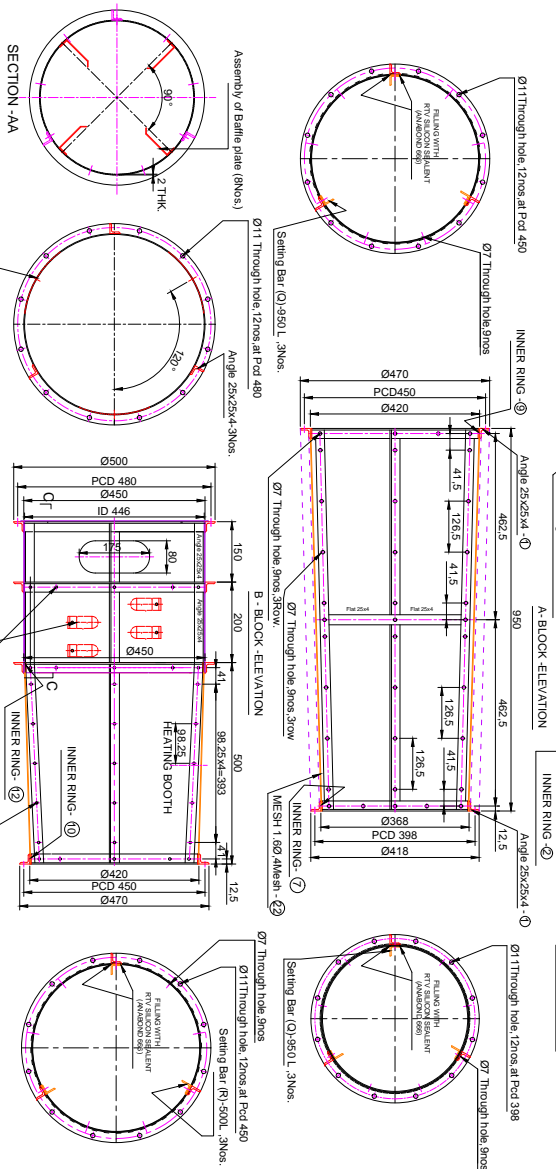
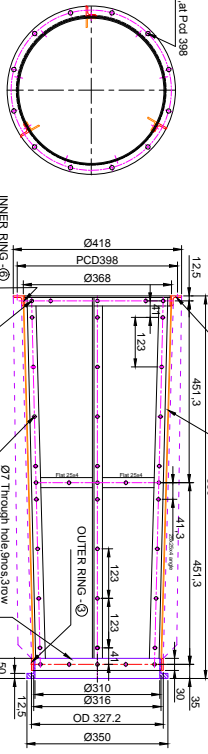
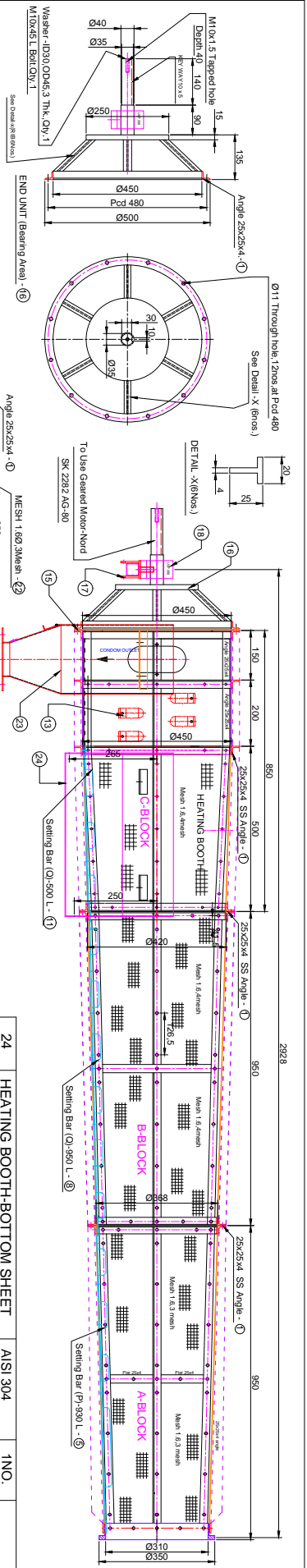

SL.NO.	DESCRIPTIONS	MATERIAL	QTY.	REMARKS
24	HEATING BOOTH-BOTTOM SHEET	AI SI 304	1NO.	
23	CHUTE FOR EJECTOR	AI SI 304	1NO.	
22	WOVEN PLAIN MESH(PLAIN WEAVE)B&C Block	AI SI 304	1NO.	WIRE DIA T.626-16SWG Size of opening - 6.843mm % of opening - 65.3
21	WOVEN PLAIN MESH(PLAIN WEAVE) A BLOCK	AI SI 304	1NO.	WIRE DIA T.626-16SWG Size of opening - 6.843mm % of opening - 65.3
20	BOLT AND NUT	AI SI 304	36 NOS.	M10x25 8Spring washer
19	Slotted Round Head Machine screw&Nut	AI SI 304L	144 NOS.	M6x25.8Spring washer
18	BEARING UCP 208 (NTN)		1NO.	Shaft dia 40
17	BEARING SUPPORT PLATE	AI SI 304 L	1NO.	
16	END UNIT (BEARING AREA)	AI SI 304 L	1NO.	see detail no. 13
15	END PLATE	AI SI 304 L	1NO.	OD =435x1.6 THK.
14	INNER RING OF CONDOM OUTLET	AI SI 304 L	1NO.	ID=46x375 Lx2THK & OD =400x2THK
13	BAFFLE PLATE	AI SI 304	8 NOS.	3 THK.
12	INNER RING OF C BLOCK	AI SI 304 L	1NO.	ID=438.8x25x2THK.
11	SETTING BAR FOR C BLOCK - 500 L (R)	AI SI 304 L	3NOS.	Angle 25x25x3THK.
10	INNER RING OF C BLOCK	AI SI 304 L	1NO.	ID=412.8x25x2THK.
9	INNER RING OF B BLOCK	AI SI 304 L	1NO.	ID=412.8x25x2THK.
8	SETTING BAR FOR B BLOCK - 950 L (Q)	AI SI 304 L	3NOS.	Angle 25x25x3THK.
7	INNER RING OF B BLOCK	AI SI 304 L	1NO.	ID=360.8x25x2THK.
6	INNER RING OF A BLOCK	AI SI 304 L	1NO.	ID=360.8x25x2THK.
5	SETTING BAR FOR A BLOCK - 930 L (P)	AI SI 304 L	3NOS.	Angle 25x25x3THK.
4	SUB-ASSEMBLY (ROLLER UNIT)	AI SI 304 L	3NOS.	SS Bearing 6001 zz 6NOS.
3	OUTER RING OF A BLOCK	AI SI 304 L	1NO.	ID=319.2x30x4 THK.
2	INNER RING OF A BLOCK	AI SI 304 L	1NO.	ID =310x50x3 THK.
1	FRAME MAIN	AI SI 304 L	1SET	Angle 25x25x4

HLL LIFECARE LIMITED.
Thiruvananthapuram-5

TITLE:-
DEHYDRATOR PARTS (BTADL CDM)

MATERIAL:	AI SI 316 L
DRAWN BY:	PAUL M P
CHECKED BY:	
APPROVED BY:	
DATE:	06-12-2013
SCALE:	
ALL DIMENSIONS ARE IN MM	

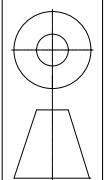

Drig.no:- HLL-CED-C2-011-00
SHEET NO: 2 OF 3
REV. 04
DATE. 29-05-2014

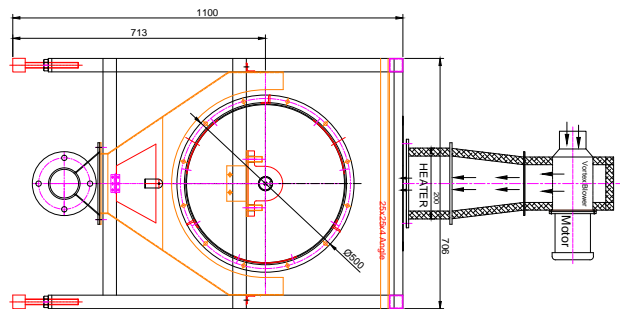

L. SIDE VIEW

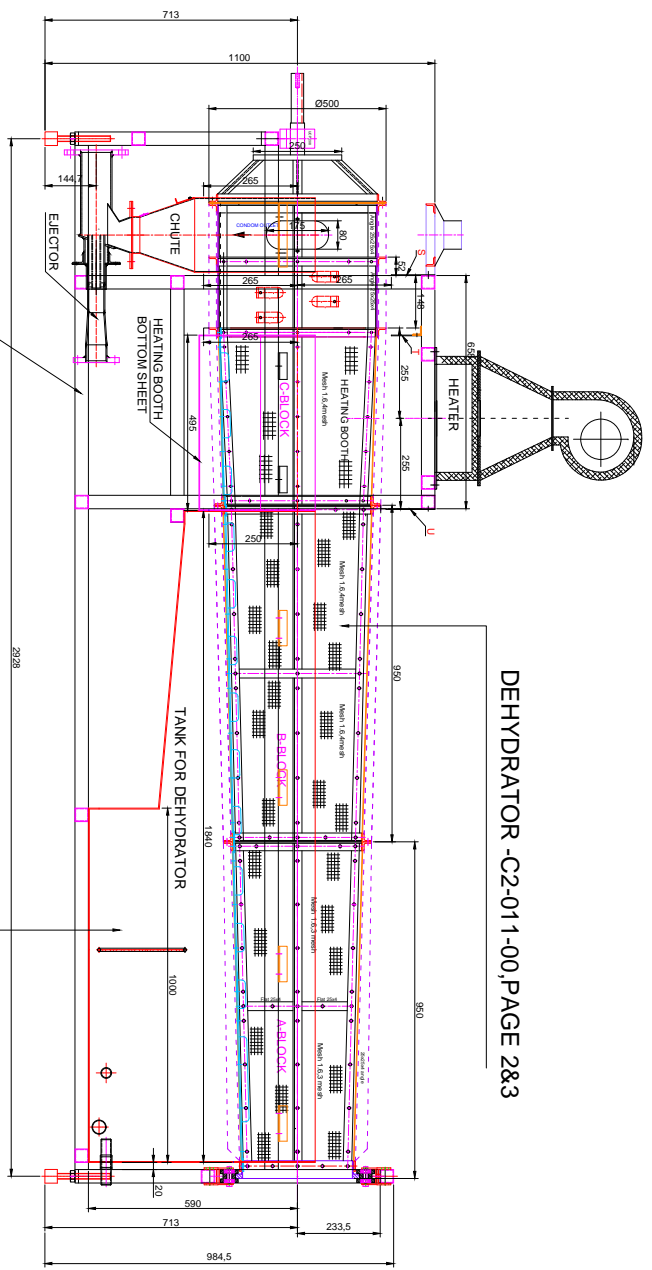

STRUCTURAL FRAME -C2-011-02

TANK -C2-011-01

ELEVATION

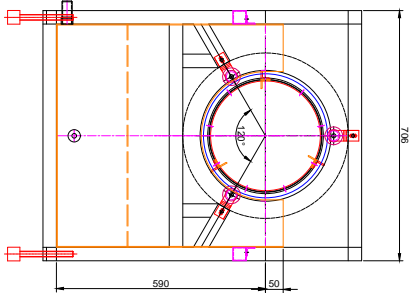

R. SIDE VIEW

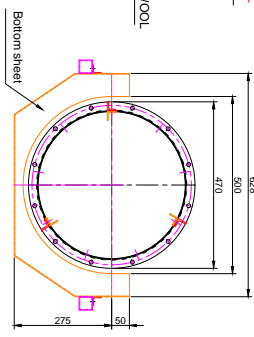
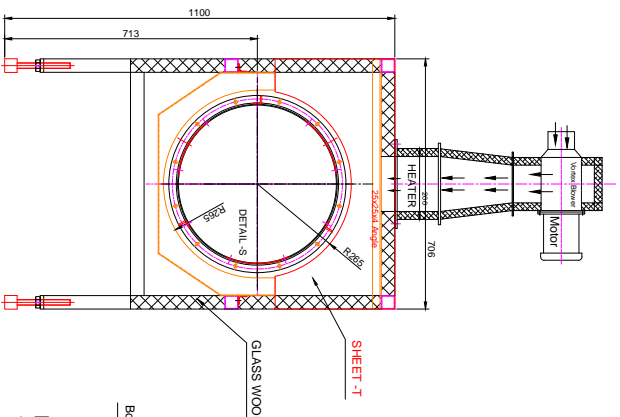

R. SIDE VIEW OF

HEATING BOOTH L. SIDE

HEATING BOOTH BOTTOM SHEET

HLL LIFECARE LIMITED. Thiruvananthapuram-5		NO.OFF.
TITLE:- DEHYDRATOR UNIT ASSEMBLY		
MATERIAL: AISI 316 C-139NM02T1281	DRAWN BY: PAUL M.P	
CHECKED BY: DATE: 06-12-2013	APPROVED BY:	
SCALE: ALL DIMENSIONS ARE IN M.M	Drg.no:- HLL-CED-C2-011-00	REV:- 04 DATE:-29-05-2014
SHEET NO: 1 OF 3		

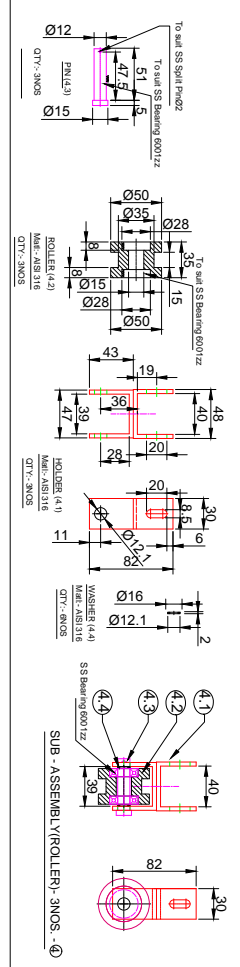
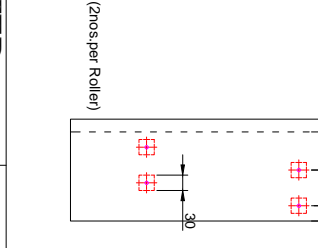
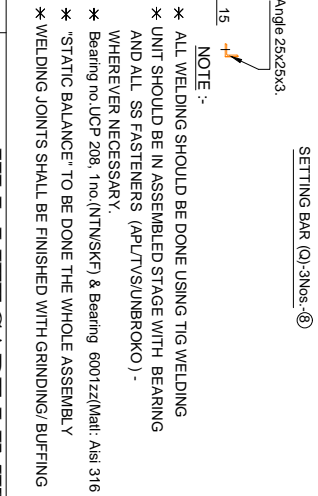
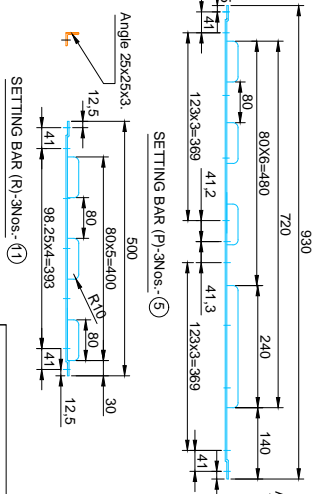
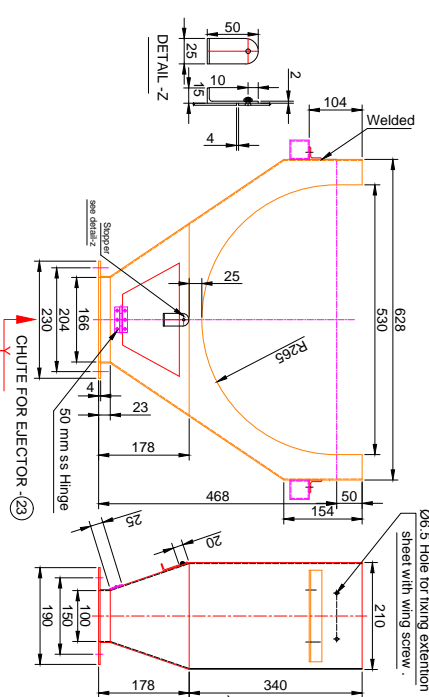
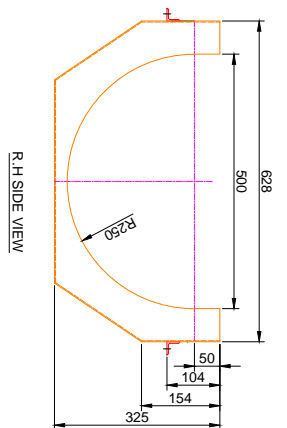
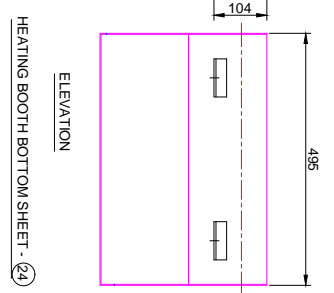
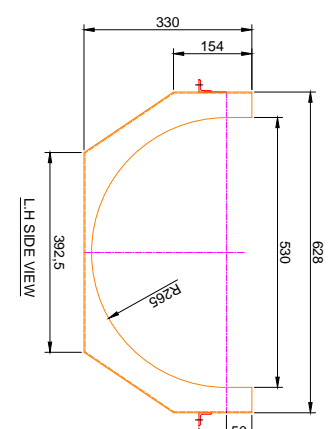
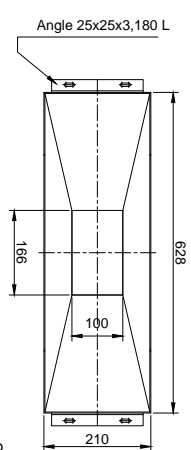
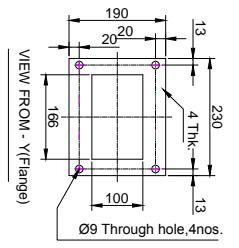
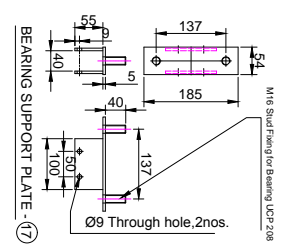
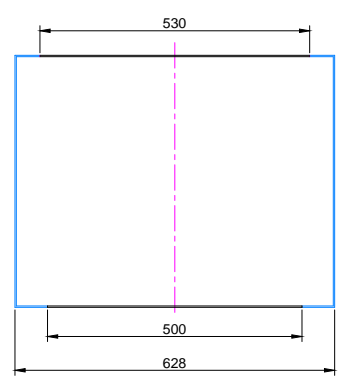
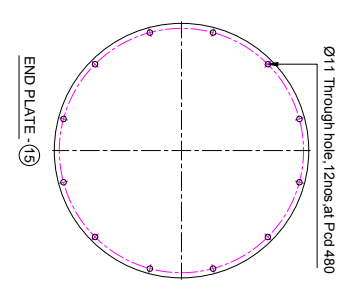
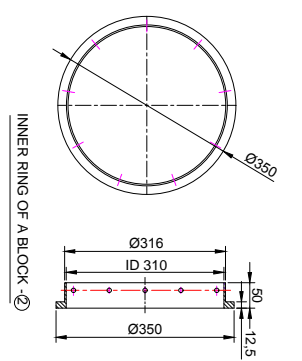

MATERIAL: AISI 316 (S31600) C13N8M02T28)		NO.OFF.	
DRAWN BY: PAUL M P		TITLE:- DEHYDRATOR PARTS (BTADL CDM)	
CHECKED BY:		Drig.no:- HLL-CED-C2-011-00	
APPROVED BY:		SHEET NO: 3 OF 3	
DATE: 06-12-2013		REV:- 04	
SCALE:		DATE:-29-05-2014	
ALL DIMENSIONS ARE IN MM			

HLL LIFECARE LIMITED.
Thiruvananthapuram-5

NOTE :-
* ALL WELDING SHOULD BE DONE USING TIG WELDING
* UNIT SHOULD BE IN ASSEMBLED STAGE WITH BEARING AND ALL SS FASTENERS (APLTVS/UNBROKO) - WHEREVER NECESSARY.
* Bearing no UCP 208, 1no.(NTNSKF) & Bearing 6001zz(Mat: Aisi 316 (2nos per Roller)
* "STATIC BALANCE" TO BE DONE THE WHOLE ASSEMBLY
* WELDING JOINTS SHALL BE FINISHED WITH GRINDING/ BUFFING

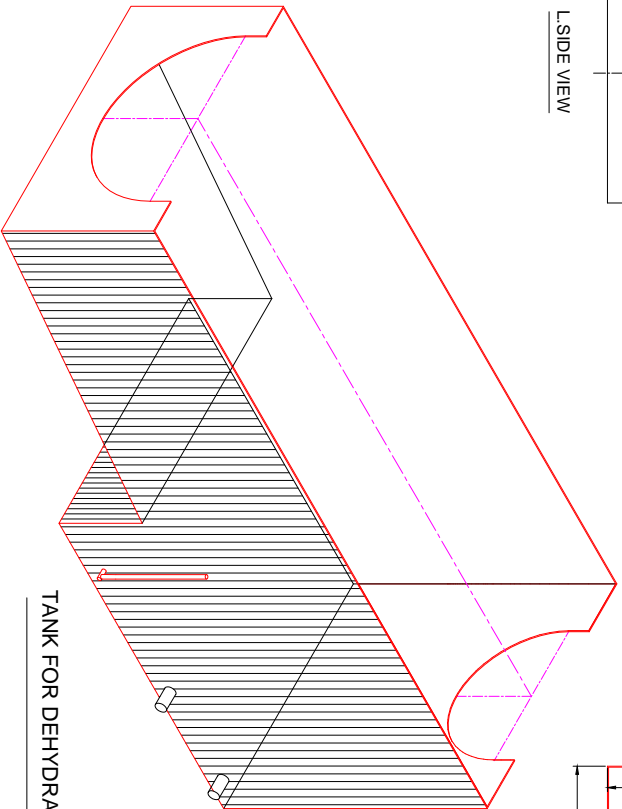
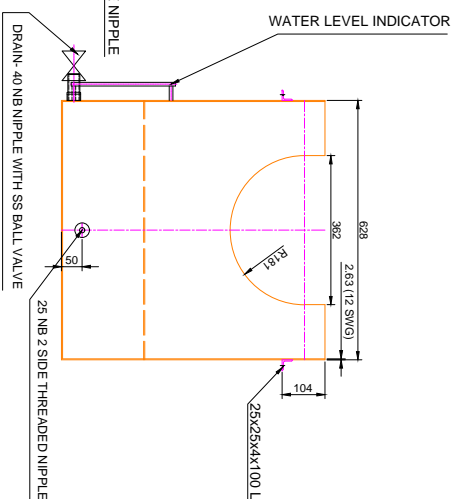
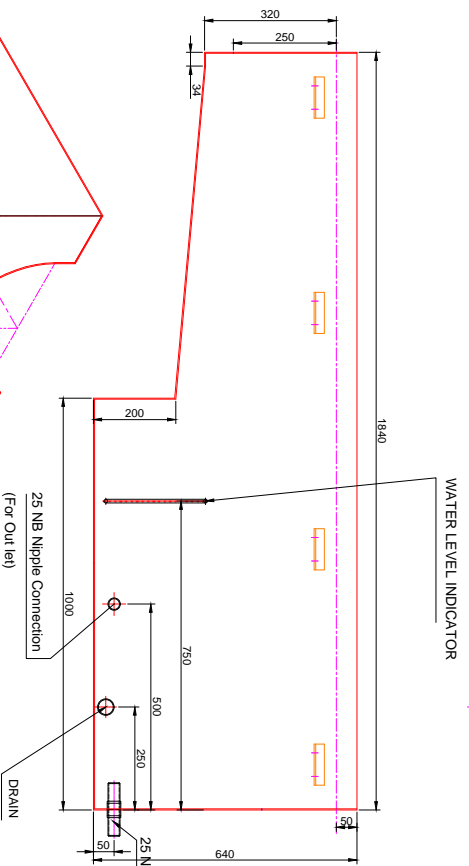
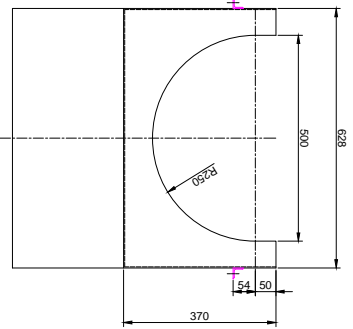
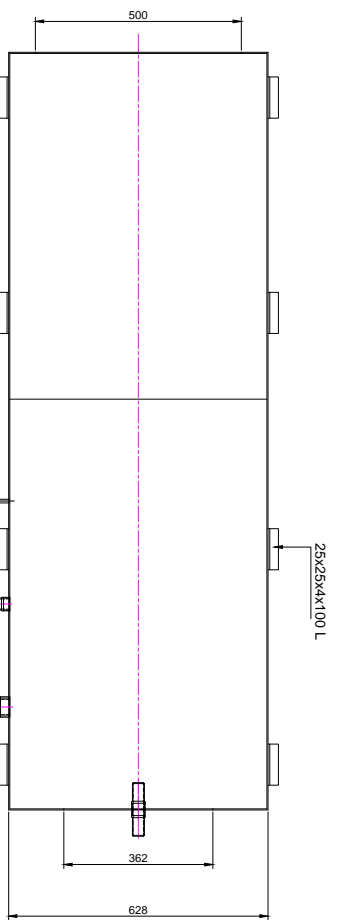

TANK FOR DEHYDRATOR

HLL LIFECARE LIMITED.		NO.OFF:
Thiruvananthapuram-5		
MATERIAL: ASTM A312 (1570-07 C-115N8M2128)	DRAWN BY: PAUL M.P	
CHECKED BY:		
APPROVED BY:		
DATE: 06-12-2013		
SCALE:		
ALL DIMENSIONS ARE IN M.M		
TITLE: TANK FOR DEHYDRATOR (BTADL CDM)		
Dwg.no:- HLL-CED-C2-011-01		
SHEET NO: 1 OF 1	REV:	DATE:-07-05-2014

