

TENDER DOCUMENT

TURNKEY WORKS FOR SETTING UP OF

**AMRIT PHARMACY
AT
NIMHANS, BENGALURU, KARNATAKA**



**PROJECTS DIVISION,
HLL LIFECARE LIMITED**

(A GOVT. OF INDIA ENTERPRISE)

Corporate and Registered Office:

HLL Bhavan, Poojappura,

Thiruvananthapuram – 695012, Kerala, India

Phone +91 471 2354949 / 2775500/ 2775588

Web: www.lifecarehll.com

JANUARY 2018

HLL LIFECARE LIMITED

(A Government of India Enterprise)
 Projects Division
 Corporate Head Office, Poojappura.P.O,
 Thiruvananthapuram – 695012,
 Kerala, India
 Phn: 0471- 2354949, 2775588

INVITATION FOR BIDS (IFB)

IFB No : HLL/CHO/PROJ/RBD/AMRIT-NIMHANS/2017-18

Date : 05-01-2018

HLL Lifecare Limited (HLL), a Government of India Enterprise is in the process of setting up of AMRIT Pharmacies at various locations in India. For the said project, sealed and super scribed bids are invited from competent and experienced Suppliers/Contractors who are capable to do the following work meeting their requirements as per our tender.

Sl. No	Brief Description of Item/Work	Qty	EMD in Rs
1	Turnkey works for setting up of AMRIT Pharmacy at National Institute of Mental Health and Neurosciences (NIMHANS), Bengaluru, Karnataka as per <u>Schedule of Work</u> enclosed.	As per Schedule V- A & B	Rs 30,000/-

2. The bid documents will be available up to 15.00 Hrs. on the previous working day of the opening of the bids. The scheduled date for issue, receipt and opening of bids is as follows.

- a) Date of issue of tender document - 05-01-2018 onwards
- b) Last date and time for receipt of bids - 19-01-2018 up to 15.00 Hrs.
- c) Date and time of opening of bids - 19-01-2018, 15.30 Hrs.
- d) Address for communication, receipt and place of opening of bids:

SENIOR MANAGER (PROJECTS),

PROJECTS DIVISION,
 HLL LIFECARE LIMITED,
 Corporate Head Office, Poojappura.P.O,
 Thiruvananthapuram – 695012, Kerala, India
 Phn: 0471- 2354949, 2775588
 E-mail: choprojects@lifecarehll.com, harikrishnankp@lifecarehll.com

3. The completed and sealed bid documents should be submitted to Senior Manager (Projects), in the above address along with the EMD. The outer cover should bear the Enquiry No, closing date and General description of item tendered, and the words “DO NOT OPEN BEFORE” 15.30 Hrs (IST) on ----- (Indicate the Closing Date). EMD shall be submitted in the form of demand draft drawn from a nationalized bank in favor of **HLL**

Lifecare Limited payable at Thiruvananthapuram. Bids received after due date and time will be rejected. Any bid not accompanied by EMD will be rejected.

4. Bids will be opened in the presence of Bidders representative(s) who choose to attend on the specified date and time, at the office of HLL at the address given in Clause 2 (d) above.
5. In the event of the date specified for bid receipt and opening being declared as a closed holiday for the above purchaser's office, the due date for submission of bids and opening of bids will be the following working day at the appointed times.
6. HLL may, at its discretion, extend this deadline for submission of bids by amending the Bid Documents or any other reasons, in which case all rights and obligations of HLL and Bidders previously subject to the deadline will thereafter be subject to the deadline as extended.
7. HLL will not be held responsible for the postal delay, if any, in the delivery of the bidding document or the non-receipt of the same. Bids sent by Telex/Fax/Telegraph will not be accepted.
8. The EMD should be enclosed in a separate envelope and super scribed as "EMD" and to be attached in the main cover.
9. SSI units interested in availing exemption from payment of EMD should submit a valid copy of their registration certificate issued by the concerned DIC or NSIC.
10. The company reserves the right to club or split the items of works, change the qualifying criteria at their discretion and to reject or cancel the Invitation for bids without assigning any reason thereof.
11. The Bid must include the following information;
 - a. Enquiry No.
 - b. EMD
 - c. Promised Delivery/Completion Schedule
 - d. Price Schedule in Format For Quoting (Schedule III)
 - e. All other documents/certificate/information as specified in the bid document.
12. In addition to the invitation for bids, the bidding documents include the following schedules.

Schedule I	-	Conditions of Contract
Schedule II	-	Acceptance Form
Schedule III	-	Capability Certificate
Schedule IV	-	Performance Statement
Schedule V-A	-	Schedule of Turnkey works
Schedule V-B	-	Schedule of Capital Items

SENIOR MANAGER (PROJECTS)

SCHEDULE I

CONDITIONS OF CONTRACT

1) PRICE

The price quoted should be inclusive of all material cost, loading and unloading charges, all applicable taxes and other levies, labor charges, insurance etc. The **Schedule** is enclosed as **Schedule V-A & B**.

Price quoted should be firm without any escalation till the order is completely executed.

2) TAXES/DUTIES/LEVIES

The contractor shall be entirely responsible for all applicable taxes including GST, duties, license fees etc. incurred until successful completion of contract.

3) ESCALATION

The rates quoted by the Contractor in the contract documents shall be final and shall not be subjected to any change due to the increase in labour wages or inflation in the cost of materials or any other price variations due to any reason during the stipulated time period of the contract or during the extended time period of completion.

Rates quoted should be inclusive of all cost of materials, Tools/Equipments labor charges, conveyance to site, handling charges, loading and unloading charges, hiring charges, clearing of debris, statutory payments etc.

4) COMPLETION TIME

Work should be completed within **4 WEEKS** from the date of issuing the Letter Of Intent or Work Order.

5) PAYMENT TERMS

The contractor can submit two running account bills during the work period and payment made as below:

- a) 80% of the bill value will be paid on each running account bill submitted by the contractor.
- b) Balance 20% will be paid along with the final bill only after issue of Work Completion certificate by Engineer In Charge/Officer In Charge of HLL Lifecare Ltd.

5% amount of the Bill will be retained as retention money and will be released only after the Defect liability period of 12 months.

The running account bills are to be submitted detailing the work description, quantity and rate as per the Work Order. Payment will be made against actual measurements recorded and certified jointly by HLL Engineer in charge and the Contractor's representative. For supply of capital items, duly certified delivery challan/supporting documents such as Warranty Certificates etc. shall be enclosed along with bill.

Tax Deduction: All statutory deductions like GST, Income Tax, Works Contract Tax, E.S.I., P.F. or any other government-imposed liabilities shall be borne by the Contractor (as applicable at the time of execution of job) and shall be deducted from each bill submitted by the Contractor.

6) SECURITY DEPOSIT

- 6.1 Simultaneously with the execution of the contract successful bidder shall furnish a Security deposit in the form of a Demand Draft from a nationalised bank drawn in favour of HLL Lifecare Limited, Thiruvananthapuram payable at Thiruvananthapuram or a Bank Guarantee from a nationalised bank, for an amount equal to 5% of the total contract value as Security Deposit for his faithful execution of contract. The Security deposit should be valid until successful completion of the contract and acceptance of the Equipment/works by the Purchaser/Owner and will be released after acceptance of the Equipment/works by the Purchaser/Owner. In case of a delay in the works the validity of security deposit shall be extended.
- 6.2 Within 10 days of the receipt of notification of award from the Purchaser/Owner; the successful Bidder shall furnish the security deposit in the form of a Demand Draft or Bank Guarantee in the security deposit form to be sent along with the Notification of Award.
- 6.3 Failure of the successful Bidder to accept the notification of award or submission of security deposit within the timeframe shall constitute sufficient grounds for the annulment of the award and forfeiture of the EMD, in which even the Purchaser/Owner may make the award to the next lowest evaluated bidder or call for new bids.

7) EARNEST MONEY

- 7.1 Each bid must be accompanied by E.M.D.
- 7.2 The EMD is required to protect the Purchaser/Owner against risk of Bidder's conduct, which would warrant the security's forfeiture.
- a. The EMD shall be in the form of cash deposit or demand draft from a nationalized bank drawn in favour of HLL Lifecare Limited, Thiruvananthapuram payable at Thiruvananthapuram.
 - b. E.M.D. from unsuccessful bidders will be returned after the acceptance of order by the L1 party.
 - c. In the case of successful bidder, the Earnest Money will be returned after signing the contract, and submission of Security Deposit, which they will have to offer for the faithful execution of the contract.
- 7.3 The EMD may be forfeited:
- (a) If a Bidder withdraws its bid during the period of bid validity specified by the Bidder on the Bidding Document; or
 - (b) In case of the successful Bidder, if the Bidder fails:
 - (i) to sign the Contract
 - (ii) to furnish security deposit

8) INDEMNIFICATION CLAUSE

The Bidder shall indemnify and hold harmless the Owner/Purchaser from and against the below mentioned:

- i. All claims, demands, action, proceedings, losses, damages, liabilities, cost, charges, expenses or obligations that are occasioned or may occasion to HLL as a result of our non-payment of any statutory dues levied/leviable on the Contractor or the Contractor committing breach of any the rules, regulations, orders, directives, instructions that may be issued by any authority under various Labor Laws, PF, ESI Acts and all other applicable Laws/Acts/Rules or any other Statute or Laws for the time being in force
- ii. Any damages, loss or expenses due to or resulting from any negligence or breach of duty on our part or on the part of Sub-Contractor/s, if any, servants or agents of the Bidder.
- iii. Claims, if any, of the employee or the Contractor and its Sub Contractor/s, under the Workmen's Compensation Act, 1923 and Employer's Liability Act 1938 or Various Labor Laws or any other Laws rules and regulations in force for the time being in India and any acts replacing and/or amending the same or any of the same as may be in force at the time and under any law in respect of injuries to persons or property arising out of and in the course of the execution of the contract work and / or arising out of and in the course of employment of any workmen / employee.
- iv. Any non - compliance or improper compliance of statutes, rules and regulations which are applicable to HLL and also to the Contractor and to the employees , in respect of (a) Employees' Provident Fund and Miscellaneous Provision Act, 1952, (b) Employees State Insurance Act, 1948, (c) Contract Labor (R&A) Act, 1970 (d) Minimum Wages Act, 1948 (e) Payment of Wages Act, 1936 (f) Bonus Act, 1965 (g) Workmen's Compensation Act, 1923 and / or any other laws which may become applicable in respect of the Contract/ Agreement between HLL and the Bidder.
- v. Any Act or omission by us or our Sub-contractor/s, if any, our /their servants or agents which may involve any loss, damages, liability, civil or criminal action.
- vi. To protect against all claims for damage caused due to non-obtaining of insurance policy during the project period.

9) DEFECT LIABILITY PERIOD:

The defect liability period of the work shall be 12 months from the date of completion of the work and this date will start from successful completion and handing over. If any damage or defect occurs in the work during this period then the Contractor shall rectify the damage or defect at his own expense to the satisfaction of the Purchaser/Owner. If the Contractor fails to do so, then the Purchaser/Owner shall have the authority to get the work done by other means and the expenditure incurred shall be recovered from the Contractor.

Even if Inspection and/or tests are fully carried out by Purchaser/Owner or their representatives, the Contractor is not absolved to any degree of his responsibility to ensure that all equipment fabricated comply strictly with the requirements as per specifications given in the order, and the Purchaser/Owner shall be free to point out any defect till the defect liability period is over.

10) FORCE MAJEURE

- a. Neither the Contractor nor the Purchaser/Owner shall be considered in default in the performance of their obligations as per the Contract so long as such performance is prevented or delayed because of strikes, war, hostilities, revolution, civil commotion, epidemics, accidents, fire, cyclone, flood or because of any law and order proclamation, regulation or ordinance of Government or subdivision thereof or because of any act of God. The proof of existence of force majeure shall be provided by the party claiming it to the satisfaction of the other.
- b. The Contractor shall advise Purchaser/Owner initially by a Fax, followed by post, the beginning and end of any of the above causes of delay, failing which Purchaser/Owner shall not be liable to consider delays due to the above reasons. Notice as stated above should be given even in case where only the Contractor's bids are under the consideration of the Purchaser/Owner and no acceptance of the same has been given and detailed order issued.
- c. In the event of definite delay even if arising out of reasons due to force majeure, Purchaser/Owner shall have the right at their discretion to cancel the Order or part of the Order without any liability on their part to make any payment to the Contractor while reserving the right to claim refund of and any payment if advanced or paid to Contractor.

11) DELAY IN WORK EXECUTION DUE TO REASONS BEYOND CONTRACTOR'S CONTROL

- 11.1 Force majeure: If the execution of work is delayed due to force majeure, then Purchaser/Owner as per the affected period may extend the time period.
- 11.2 In case work is delayed due to non-availability of stores supplied by Owner or any decision by Owner holding the progress of work, the contractor then upon any such happening causing delay shall immediately but not later than 10 days, give notice thereof in writing to the Owner, but nevertheless use constantly his best effort to prevent or make good delay. The Owner may in his discretion grant such extension of time as may appear reasonable to him and the same shall be communicated to the contractor in writing and shall be final and binding on him and the contractor shall be bound to complete the work within such extended time.

12) LIQUIDATED DAMAGES FOR DELAYS

If the work is not completed and handed over to the Purchaser/Owner within the time stipulated in the Order, Purchaser/Owner may at their option, either (1) recover from the Contractor liquidated damages at the rate of 0.5 % of the total contract value for every week of delay, subject to a maximum of 7.5 % of the total contract value, or (2) at the risk and cost of the Contractor and without prejudice to the other remedies/rights as per the Contract, terminate the order wholly or partially and complete it themselves or reassign it to other contractors.

13) SPECIAL INSTRUCTIONS

- 13.1 The bidder shall visit the site before quoting for the work and also take their own assessments before quoting of bids.**
- 13.2 All pages of the bid, except for un-amended printed literature shall be signed by the person or persons signing the bid. The seal of the company shall be stamped in all pages.
- 13.3 Bids shall be made in English. The bid shall contain no interlineations, erasures or overwriting except as necessary to correct errors made by the Bidder, in which case such corrections shall be signed by the person or persons signing the bid.
- 13.4 To assist in the examination, evaluation and comparison of bids, the Owner may, at its discretion, ask the bidder for a clarification of its bid. The request for clarification and the response shall be in writing and no change in the rate or substance of the bid shall be sought, offered or permitted.
- 13.5 Arithmetical errors will be rectified on the following basis. If there is a discrepancy between the unit price and the total price that is obtained by multiplying the unit price and quantity, the unit price shall prevail and the total price shall be calculated. If there is a discrepancy between the words and figures of unit price, the amount in words of unit price shall prevail.
- 13.6 Prior to the detailed evaluation, the Owner will determine the substantial responsiveness of each bid to the bidding documents. For purposes of these clauses, a substantially responsive bid is one, which conforms to specifications and all the terms and conditions of the bidding documents without material deviation. The Owner's determination of a bid's responsiveness is to be based on the contents of the bid itself without recourse to extrinsic evidence.
- 13.7 The Owner's determination as to the substantial responsiveness or otherwise of each bid or consideration of a minor informality or non-conformity or irregularity is final and conclusive.
- 13.8 The Owner reserves the right to negotiate with the lowest evaluated responsive bidder.
- 13.9 The Owner will award the Contract to the successful Bidder whose bid has been determined to be substantially responsive and has been determined as the lowest evaluated bid provided further that the Bidder is determined to be qualified to perform the Contract satisfactorily for the items offered.
- 13.10 Prior to the expiration of the period of bid validity, the Owner will notify the successful Bidder in writing by or cable or telex or fax, to be confirmed in writing by post, that its bid has been accepted. The notification of award may be sent in the form of Letter of Intent and/or Work order.
- 13.11 The signed acceptance of the notification of award by the Contractor will constitute a concluded contract.

- 13.12 The work should be carried out without causing any inconvenience to the public and shall ensure that no damages are caused to the existing site premises.
- 13.13 During the execution of work, the contractor or authorized representative should be present at site.
- 13.14 All Materials, Equipment's/ Tools required for the work should be arranged by the contractor and brought to site for the timely completion of the work.
- 13.15 The materials used shall be as per specification and of good quality.
- 13.16 The Contractor has to arrange necessary insurance coverage for the machine, workmen etc. deployed by him. He shall arrange all safety measures to protect his workmen and also the properties of HLL/MCG Office Building. The work site safety of all employees, their ESI, PF etc will have to be borne by the contractor.
- 13.17 The work should be carried out in truly professional manner, neatly finished with proper line, level and plumb. Cleanliness and finishing of the job is of utmost importance. Hence the job should be done most carefully with best workmanship. For all finishing jobs samples should be approved from the Purchaser/Owner before completely executing the work.
- 13.18 The Purchaser/Owner should be immediately informed for any discrepancy in drawings, specifications and instructions in the execution of job before actual execution of particular item having discrepancy.
- 13.19 Any item found to be having been executed with poor workmanship then the Contractor shall have to rectify /reconstruct the work as specified by Purchaser/Owner. No extra charge will be admissible in such case. If CONTRACTORS fails to do so, the Purchaser/Owner reserved the right to rectify/reconstruct the work through some other agency at the expenses of Contractor.
- 13.20 The schedule of activities as submitted by the Contractor shall have to be strictly adhered to. Regular progress reports shall have to be submitted by the Contractor giving all details for monitoring of the schedule.
- 13.21 The Contractor shall make initial drawings/layouts (as per site conditions) and get it approved by HLL before execution.
- 13.22 Special care is to be taken for cleanliness of the site. After the end of day's work, the site should be cleaned immediately.
- 13.23 The Contractor shall have to co-operate with the agencies executing other works in the same area.
- 13.24 While executing the work, the Contractor shall ensure safety and security of the property of the Purchaser/Owner so as to avoid theft etc.

13.25 Measurement & Payment terms:

The method of measurement of completed work shall be in accordance with the standard measurement. Payment will be made on satisfactory completion of work as per the order. Interim or running account bills shall be submitted by the contractor for the work executed on the basis of such recorded measurements in the format of HLL. All such interim payments shall be regarded as payment by way of advances against final payment only, and shall not preclude the requiring of bad, unsound and imperfect or unskilled work to be rejected, removed, taken away and reconstructed or re erected. Any certificate given by the officer relating to the work done or materials delivered forming part of such payment, may be modified, or corrected by any subsequent such certificate(s) or by the final certificate and shall not by itself be conclusive evident that any work or material so which it relates is /are in accordance with the contract and certificate. Any such interim payment,/any part there of shall not in any respect conclude, determine or affect in any way powers of the engineer in charge under the contract or any of such payment s be treated as final settlement and adjustment of accounts or in any way vary or affect the contract.

13.26 If contractor is executing any extra items as per direction of Engineer in charge / Officer in charge, the rates shall be worked out as per the latest CPWD Schedule of Rates and in case, the item is not included in the CPWD schedule, the rate shall be arrived as per prevailing Market rates.

13.27 The Quantity shown in the schedule is an approximate estimated quantity. No rate revision will be entertained if the quantity increases/decreases due to the site condition while executing the work.

13.28 Water and Electricity: The contractor shall make his own arrangement for water and electricity required for the works. HLL will not be responsible for the supply of either electricity or water.

13.29 During the execution of work, the contractor or authorized representative/s at least one person having technical qualification should be present at site.

13.30 The contractor shall comply with by-laws and regulation of local and statutory authorities having jurisdiction over the work and shall be responsible for payment of all statutory fees and other charges and the giving and receiving of all necessary notices and the Owner shall be kept informed of the said compliances with by-laws, payment made, notices issued and received. All statutory payments shall be made by the Contractor and the same will be reimbursed by HLL on producing original challans/receipts.

13.31 Electrical

The work shall be carried out by a contractor holding valid licence issued by the State Government/Competent Authority for carrying out installation work of all voltage classes involved, under direct supervision of the persons holding valid certificates issued or recognized by the state government/competent authority.

13.32 Final payment shall be paid only after clearing the site as per direction of Engineer-in-charge/ Officer in charge.

14) CORRESPONDENCE

All correspondence relating to this Order shall be in English, to:

SENIOR MANAGER (PROJECTS),
PROJECTS DIVISION,
HLL LIFECARE LIMITED (A Government of India Enterprise)
Corporate Head Office, Poojappura.P.O,
Thiruvananthapuram – 695012,
Kerala, India
Phn: 0471- 2354949, 2775588
E-mail: choprojects@lifecarehll.com, harikrishnankp@lifecarehll.com

15) SETTLEMENT OF DISPUTES

Arbitration shall not be a means of settlement of any dispute or claim arising out of the contract relating to the work. Any disputes or difference arising between the parties with respect to the performance of any part of this agreement or any thing connected therewith, etc shall as far as possible be mutually settled by the process of dialog and negotiation.

The Courts at Thiruvananthapuram alone shall have jurisdiction in respect of settlement of any matter arising out or in connection with the contract.

SCHEDULE II

ACCEPTANCE FORM

(To be submitted in the letter pad of the firm indicating full name and address, telephone & fax numbers etc.)

From

To

SENIOR MANAGER (PROJECTS),
PROJECTS DIVISION,
HLL LIFECARE LIMITED (A Government of India Enterprise)
Corporate Head Office, Poojappura.P.O,
Thiruvananthapuram – 695012,
Kerala, India
Phn: 0471- 2354949, 2775588
E-mail: choprojects@lifecarehll.com, harikrishnankp@lifecarehll.com

Dear Sir,

I / We, hereby offer to supply/construct/erect/install/commission the work as detailed in schedules/drawings hereto or such portion thereof as you may specify in the acceptance of Bid at the price given in the price bid and agree to hold this offer open till 90 days after the date of bid opening prescribed by the purchaser/Owner. I/We have understood the terms and conditions mentioned in the invitation for bid and Conditions of Contract furnished by you and have thoroughly examined the specifications quoted in the bid document/drawings hereto and are fully aware of the nature of the scope of work required and my/our offer is to comply strictly in accordance with the requirement and the terms and conditions mentioned above.

Yours faithfully,

SIGNATURE OF THE BIDDER

SCHEDULE III

CAPABILITY CERTIFICATE

(To be submitted in the letter pad of the firm indicating full name and address, telephone & fax numbers etc.)

I/We have the financial capability to execute the work and complete the same within the specified time period (4 weeks). The delay, if any, in taking measurements, certification of bills, submission of bills and release of payments will not affect the progress and completion of work. I have read all the terms and conditions of the tender document including payment terms and confirm my acceptance of the same.

SIGNATURE OF THE BIDDER WITH SEAL

SCHEDULE IV

PROFORMA FOR PERFORMANCE STATEMENT

Proforma for Performance Statement (for a period of last 3 year)

Name of the Tenderer:.....

Name & Address of the Tenderer / Service Provider:.....

.....

Order placed by (Full Address of Company / Consignee)	Order No. and Date	Description and quantity of ordered work and service	Value of order	Date of Completion of Contract		Remarks indicating reasons for delay, if any	Have the works been satisfactorily maintained? (Attach a documentary proof)
				As per Contract	Actual		

We hereby certify that if at any time, information furnished by us is proved to be false or incorrect, we are liable for any action as deemed fit by the Company in addition to forfeiture of earnest money.

Signature and Seal of the Bidder

.....

SCHEDULE V

SCHEDULE OF WORK

SCHEDULE V-A

Sub:	Shifting of Existing Lifecare Pharmacy and setting-up AMRIT Pharmacy Outlet				
Site Location	Shop No.3 at OPD Block, NIMHANS, Bangalore				
Item no.	Specification	Unit	Quantity	Rate in Rs.	Amount in Rs.
1	Demolishing brick work manually/ by mechanical means including stacking of serviceable material and disposal of unserviceable material within 50metres lead as per direction of Engineer-in-charge. In cement mortar	Cum	3.15		
2	15 mm cement plaster on the rough side of single or half brick wall of mix :1:4 (1 cement: 4 coarse sand)	Sqm	7.00		
3	Applying one coat of water thinnable cement primer of approved brand and manufacture on wall surface : Water thinnable cement primer	Sqm	50.00		
4	Providing and applying plaster of paris putty of 2 mm thickness over plastered surface to prepare the surface even and smooth complete.	Sqm	3.00		
5	Wall painting with acrylic emulsion paint of approved brand and manufacturer to give an even shade : Two or more coats (Color shade to be approved)	Sqm	50.00		
	ALUMINIUM WORK				
6	Providing and fixing aluminium work for doors, windows, ventilators and partitions with extruded built up standard tubular sections/ appropriate Z sections and other sections of approved make conforming to IS: 733 and IS: 1285, fixing with dash fasteners of required dia and size, including necessary filling up the gaps at junctions, i.e. at top, bottom and sides with required EPDM rubber/ neoprene gasket etc. Aluminium sections shall be smooth, rust free, straight, mitred and jointed mechanically wherever required including cleat angle, Aluminium snap beading for glazing / paneling, C.P. brass / stainless steel screws, all complete as per architectural drawings and the directions of Engineer-in-charge. (Glazing and paneling to be paid for separately)				

SCHEDULE V-A

Sub:	Shifting of Existing Lifecare Pharmacy and setting-up AMRIT Pharmacy Outlet				
Site Location	Shop No.3 at OPD Block, NIMHANS, Bangalore				
Item no.	Specification	Unit	Quantity	Rate in Rs.	Amount in Rs.
6.1	For fixed portion: Powder coated aluminium (minimum thickness of powder coating 50 micron)	Kg	25.00		
6.2	For shutters of doors, windows & ventilators including providing and fixing hinges/ pivots and making provision for fixing of fittings wherever required including the cost of EPDM rubber / neoprene gasket required (Fittings shall be paid for separately): Powder coated aluminium (minimum thickness of powder coating 50 micron)	kg	10.00		
7	Providing and fixing 12 mm thick prelaminated particle board flat pressed three layer or graded wood particle board conforming to IS: 12823 Grade I Type II, in panelling fixed in aluminum doors, windows shutters and partition frames with C.P. brass / stainless steel screws etc. complete as per architectural drawings and directions of engineer-in-charge.	Sqm	5.00		
8	Providing and fixing glazing in aluminium door, window, ventilator shutters and partitions etc. with EPDM rubber / neoprene gasket etc. complete as per the architectural drawings and the directions of Engineer-in-charge. With float glass panes of 5.50/6 mm thickness.	Sqm	5.00		
9	Providing and fixing aluminium die cast body tubular type universal hydraulic door closer (having brand logo with ISI, IS : 3564, embossed on the body, door weight upto 35 kg and door width upto 700 mm), with necessary accessories and screws etc. complete	Each	1.00		
10	Providing and fixing aluminium hanging floor door stopper, ISI marked, anodised (anodic coating not less than grade AC 10 as per IS : 1868) transparent or dyed to required colour and shade, with necessary screws etc. complete. Twin rubber stopper	Each	1.00		

SCHEDULE V-A

Sub:	Shifting of Existing Lifecare Pharmacy and setting-up AMRIT Pharmacy Outlet				
Site Location	Shop No.3 at OPD Block, NIMHANS, Bangalore				
Item no.	Specification	Unit	Quantity	Rate in Rs.	Amount in Rs.
11	Filling the gap in between aluminium frame & adjacent RCC/ Brick/ Stone work by providing weather silicon sealant over backer rod of approved quality as per architectural drawings and direction of Engineer-in-charge complete.Upto 5mm depth and 5 mm width	Metre	30.00		
12	Providing and fixing aluminium round shape handle of outer dia 100 mm with SS screws etc. complete as per direction of Engineer-incharge Anodized (AC 15) aluminium	Each	2.00		
13	Providing and fixing aluminium tower bolts, ISI marked, anodised (anodic coating not less than grade AC 10 as per IS : 1868) transparent or dyed to required colour or shade, with necessary screws etc. complete :300x10 mm	Each	2.00		
14	Providing and fixing bright finished brass 100 mm mortice latch and lock with 6 levers and a pair of lever handles of approved quality with necessary screws etc. complete.	Each	1.00		
15	Providing and sticking Frosted Crystal Glass Film on glass panes in partition , doors etc.	Sqm	5.00		
	RACKS/ DISPENSING COUNTERS				
16	Wall Hung Medicine Storage Rack - Supply and fabrication at site of wooden racks of size 450 mm X 600 mm with 12mm ply on all sides, Top & Bottom. Shelves with 19mm Block Board and all around laminate pasted (all sides). Complete with all accessories including fixing. Make laminate : Greenlam - 283 Sky blue / Merino / Century / Equivalent. ONLY FRONT ELEVATION WILL BE MEASURED	sqm	4.00		

SCHEDULE V-A

Sub:	Shifting of Existing Lifecare Pharmacy and setting-up AMRIT Pharmacy Outlet				
Site Location	Shop No.3 at OPD Block, NIMHANS, Bangalore				
Item no.	Specification	Unit	Quantity	Rate in Rs.	Amount in Rs.
17	COUNTER: Single level Counter, Level at 750 mm from ground and 600 mm depth. 8mm Thk WPC sheet to be used for counter top on 18mm thick commercial ply. Under counter storage unit to be fixed with individual locks and handles as per drawing, 600mm wide laminated door and Cash drawer of suitable design is to be installed including handle, lock and drawer channel. The rate is inclusive of painting, putty etc. which are necessary for the counter Make PLYWOOD: Commercial. LAMINATE: GREENLAM, MARINO OR EQUIVALANT .Only front elevation will be measured.	Sqm	2.30		
18	Supply and installation of Working Table, 3'0" X 2'0" with 18mm Ply top and two vertical support in store room as per DRW, with colour laminated sheet finish.	Nos	2.00		
	MISCELLANIOUS				
19	Shifting of existing floor mounted metal racks, table and chairs from adjacent shop (within a lead of 10m) in the same floor to proposed pharmacy and placing in position.	L.S	1.00		
20	Shifting of existing 2kVA UPS unit from adjacent shop (within a lead of 10m) in the same floor to proposed pharmacy and placing in position. The cost shall include disconnection and reconnection of all interconnection , reinstallation of batteries complete. Incoming and outgoing connection shall be paid extra as per applicable item rates.	L.S	1.00		
21	Shifting of existing Refrigerator unit & Desktop PCs from adjacent shop (within a lead of 10m) in the same floor to proposed pharmacy and placing in position.	L.S	1.00		
TOTAL AMOUNT IN RS. FOR SCHEDULE V-A					
APPLICABLE TAXES					
TOTAL FOR SCHEDULE V-A					

SCHEDULE V - B

Sub:	Setting-up of AMRIT Pharmacy Outlet at NIMHANS, BENGALURU				
Site Location	Existing HLL Lifecare Centre, OPD, NIMHANS, BENGALURU, KARNATAKA				
Item no.	Specification	Unit	Quantity	Rate in Rs.	Amount in Rs.
A	Civil & Electrical Works				
	Civil works				
1	Removing white or colour wash by scrapping and sand papering and preparing the surface smooth including necessary repairs to scratches etc. Complete	Sqm	155.00		
2	Demolishing brick work manually/ by mechanical means including stackingof serviceable material and disposal of unserviceable material within 50metres lead as per direction of Engineer-in-charge. In cement mortar	Cum	1.00		
3	Brick work with common burnt clay F.P.S. (non modular) bricks of class designation 7.5 in superstructure above plinth level up to floor V level in all shapes and sizes in :Cement mortar 1:4 (1 cement : 4 coarse sand)	Cum	3.00		
4	15 mm cement plaster on the rough side of single or half brick wall of mix :1:4 (1 cement: 4 coarse sand)	Sqm	6.00		
5	12 mm cement plaster of mix : 1:4 (1 cement: 4 coarse sand)	Sqm	6.00		
6	Applying one coat of water thinnable cement primer of approved brand and manufacture on wall surface : Water thinnable cement primer	Sqm	155.00		
7	Providing and applying plaster of paris putty of 2 mm thickness over plastered surface to prepare the surface even and smooth complete.	Sqm	42.00		
8	Wall painting with acrylic emulsion paint of approved brand and manufacturer to give an even shade : Two or more coats (Color shade to be approved)	Sqm	155.00		
	Providing and fixing tiled false ceiling of approved materials of size 595x595 mm in true horizontal level, suspended on inter locking metal grid of hot dipped galvanized steel sections (galvanized @ 120 grams/ sqm, both side inclusive) consisting of main "T" runner with suitably spaced joints to get required length and of size 24x38 mm made from 0.30 mm thick(minimum) sheet, spaced at 1200 mm center to center and cross "T" of size 24x25 mm made of 0.30 mm thick (minimum) sheet, 1200 mm long spaced between main "T" at 600 mm center to center to form a grid of 1200x600 mm and secondary cross "T" of length 600 mm and size 24x25 mm made of 0.30 mm thick (minimum) sheet to be interlocked at middle of				

SCHEDULE V - B

Sub:	Setting-up of AMRIT Pharmacy Outlet at NIMHANS, BENGALURU				
Site Location	Existing HLL Lifecare Centre, OPD, NIMHANS, BENGALURU, KARNATAKA				
Item no.	Specification	Unit	Quantity	Rate in Rs.	Amount in Rs.
9	<p>the 1200x600 mm panel to form grids of 600x600 mm and wall angle of size 24x24x0.3 mm and laying false ceiling tiles of approved texture in the grid including, required cutting/making, opening for services like diffusers, grills, light fittings, fixtures, smoke detectors etc. Main "T" runners to be suspended from ceiling using GI slotted cleats of size 27 x 37 x 25 x1.6 mm fixed to ceiling with 12.5 mm dia and 50 mm long dash fasteners, 4mm GI adjustable rods with galvanised butterfly level clips of size 85 x 30 x 0.8 mm spaced at 1200 mm center to center along main T, bottomexposed width of 24 mm of all T-sections shall be pre-painted with polyester paint, all complete for all heights as per specifications, drawings and asdirected by Engineer-in-charge.</p>	Sqm	20.00		
	<p>12.5 mm thick square edge PVC Laminated Gypsum Tile of size 595x595 mm, made of Gypsum plasterboard,manufactured from natural gypsum as per IS 2095 part I and laminated with white 0.16mm thick fire retardant PVC film on the face side and 12micron metalized polyester on the back side with all edges sealed with the face side PVC film which goes around and wraps the edges and is bonded to the edges and the back side metalized polyester film so as to make the tile a completely sealed unit.</p>				
10	<p>Providing and fixing aluminium work for doors, windows, ventilators and partitions with extruded built up standard tubular sections/ appropriate Z sections and other sections of approved make conforming to IS: 733 and IS: 1285, fixing with dash fasteners of required dia and size, including necessary filling up the gaps at junctions, i.e. at top, bottom and sides with required EPDM rubber/ neoprene gasket etc. Aluminium sections shall be smooth, rust free, straight, mitred and jointed mechanically wherever required including cleat angle, Aluminium snap beading for glazing / paneling, C.P. brass / stainless steel screws, all complete as per architectural drawings and the directions of Engineer-in-charge. (Glazing and paneling to be paid for separately) :</p>				
11	<p>For fixed portion:Powder coated aluminium (minimum thickness of powder coating 50 micron)</p>	Kg	40.00		

SCHEDULE V - B

Sub:	Setting-up of AMRIT Pharmacy Outlet at NIMHANS, BENGALURU				
Site Location	Existing HLL Lifecare Centre, OPD, NIMHANS, BENGALURU, KARNATAKA				
Item no.	Specification	Unit	Quantity	Rate in Rs.	Amount in Rs.
12	For shutters of doors, windows & ventilators including providing and fixing hinges/ pivots and making provision for fixing of fittings wherever required including the cost of EPDM rubber / neoprene gasket required (Fittings shall be paid for separately):Powder coated aluminium (minimum thickness of powder coating 50 micron)	kg	14.00		
13	Providing and fixing 12 mm thick prelaminate particle board flat pressed three layer or graded wood particle board conforming to IS: 12823 Grade I Type II, in panelling fixed in aluminum doors, windows shutters and partition frames with C.P. brass / stainless steel screws etc. complete as per architectural drawings and directions of engineer-in-charge.	Sqm	20.00		
14	Providing and fixing glazing in aluminium door, window, ventilator shutters and partitions etc.withEPDM rubber / neoprene gasket etc.complete as per the architectural drawings and the directions of Engineer-in-charge. With float glass panes of 5.50/6 mm thickness.	Sqm	17.00		
15	Providing and fixing aluminium die cast body tubular type universal hydraulic door closer (having brand logo with ISI, IS : 3564, embossed on the body, door weight upto 35 kg and door width upto 700 mm), with necessary accessories and screws etc. complete	Each	2.00		
16	Providing and fixing aluminium hanging floor door stopper, ISI marked,anodised (anodic coating not less than grade AC 10 as per IS : 1868) transparent or dyed to required colour and shade, with necessary screws etc. complete.Twin rubber stopper	Each	2.00		
17	Filling the gap in between aluminium frame & adjacent RCC/ Brick/ Stone work by providing weather silicon sealant over backer rod of approved quality as per architectural drawings and direction of Engineer-in-charge complete.Upto 5mm depth and 5 mm width	Metre	54.00		
18	Providing and fixing aluminium round shape handle of outer dia 100 mm with SS screws etc. complete as per direction of Engineer-incharge Anodized (AC 15) aluminium	Each	4.00		
19	Providing and fixing aluminium tower bolts, ISI marked, anodised (anodic coating not less than grade AC 10 as per IS : 1868) transparent or dyed to required colour or shade, with necessary screws etc. complete :300x10 mm	Each	4.00		

SCHEDULE V - B					
Sub:	Setting-up of AMRIT Pharmacy Outlet at NIMHANS, BENGALURU				
Site Location	Existing HLL Lifecare Centre, OPD, NIMHANS, BENGALURU, KARNATAKA				
Item no.	Specification	Unit	Quantity	Rate in Rs.	Amount in Rs.
20	Providing and fixing bright finished brass 100 mm mortice latch and lock with 6 levers and a pair of lever handles of approved quality with necessary screws etc. complete.	Each	2.00		
21	Providing and sticking Frosted Crystal Glass Film on glass panes in partition , doors etc.	Sqm	15.00		
22	Painting with synthetic enamel paint of approved brand and manufacture to give an even shade :Two or more coats	Sqm	5.00		
23	Supply and Providing slotted angle Rack of size 2.10 M X 0.90 M and 300 mm deep at Pharmacy with 7 Racks @ 300 mm C/C	each	15.00		
24	Wall Hung Medicine Storage Rack - Supply and fabrication at site of wooden racks of size 450 mm X 600 mm with 12mm ply on all sides, Top & Bottom. Shelves with 19mm Block Board and all around laminate pasted (all sides). Complete with all accessories including fixing. Make laminate : Greenlam - 283 Sky blue / Merino / Century / Equivalent. ONLY FRONT ELEVATION WILL BE MEASURED	sqm	4.00		
25	COUNTER: Single level Counter, Level at 750 mm from ground and 600 mm depth. 8mm Thk WPC sheet to be used for counter top on 18mm thick commercial ply. Under counter storage unit to be fixed with individual locks and handles as per drawing, 600mm wide laminated door and Cash drawer of suitable design is to be installed including handle, lock and drawer channel.The rate is inclusive of painting,putty etc.which are necessary for the counter Make PLYWOOD: Commercial. LAMINATE:GREENLAM, MARINO OR EQUIVALANT .Only front elevation will be measured.	Sqm	3.00		

SCHEDULE V - B

Sub:	Setting-up of AMRIT Pharmacy Outlet at NIMHANS, BENGALURU				
Site Location	Existing HLL Lifecare Centre, OPD, NIMHANS, BENGALURU, KARNATAKA				
Item no.	Specification	Unit	Quantity	Rate in Rs.	Amount in Rs.
26	Supply and installation of Working Table,3'0"X 2'0" with 18mm Ply top and two Vertical support in store room as per DRW,with colour laminated sheet finish.	Nos	2.00		
27	Providing and fixing precoated galvanised iron profile sheets (size, shape and pitch of corrugation as approved by Engineer-in-charge) 0.50 mm (+ 0.05 %) total coated thickness with zinc coating 120 grams per sqm as per IS: 277, in 240 mpa steel grade, 5-7 microns epoxy primer on both side of the sheet and polyester top coat 15-18 microns. Sheet should have protective guard film of 25 microns minimum to avoid scratches during transportation and should be supplied in single length upto 12 metre or as desired by Engineer- in-charge. The sheet shall be fixed using self drilling /self tapping screws of size (5.5x 55 mm) with EPDM seal, complete upto any pitch in horizontal/ vertical or curved surfaces, excluding the cost of purlins, rafters and trusses and including cutting to size and shape wherever required.	sqm	10.00		
28	Structural steel work riveted, bolted or welded in built up sections, trusses and framed work, including cutting, hoisting, fixing in position and applying a priming coat of approved steel primer all complete.	kg	1600.00		
29	Providing and laying in position specified grade of reinforced cement concrete, including the cost of centering, shuttering, finishing and reinforcement -1:2:4 (1 cement : 2 coarse sand : 4 graded stone aggregate 20mm nominal size)	cum	1.00		
30	Cement concrete flooring 1:2:4 (1 cement : 2 coarse sand : 4 graded stone aggregate) finished with a floating coat of neat cement, including cement slurry, but excluding the cost of nosing of steps etc. complete. 40 mm thick with 20 mm nominal size stone aggregate	Sqm	3.00		
31	Providing and fixing Chequered tiles with cement moter 1:4 of required thickness over existing floor/pcc including cost of nosing, etc. complete.	Sqm	3.00		

SCHEDULE V - B

Sub:	Setting-up of AMRIT Pharmacy Outlet at NIMHANS, BENGALURU				
Site Location	Existing HLL Lifecare Centre, OPD, NIMHANS, BENGALURU, KARNATAKA				
Item no.	Specification	Unit	Quantity	Rate in Rs.	Amount in Rs.
B	ELECTRICAL WORKS				
	WIRING				
1	Point wiring in PVC conduit, with Modular type switch: Wiring for light point/ fan point/ exhaust fan point/ call bell point with 1.5 sq.mm FRLS PVC insulated copper conductor single core cable in surface / recessed medium class PVC conduit, with modular switch, modular plate, suitable GI box and earthing the point with 1.5 sq.mm. FRLS PVC insulated copper conductor single core cable etc as required - Group C(Recommended Makes: RRKabel/National/Ralison/RKG/Finolex/Polycab/Havells)	Point	8		
2	Wiring for light/ power plug with 2X4 sq. mm FRLS PVC insulated copper conductor single core cable in surface/ recessed medium class PVC conduit alongwith 1 No. 4 sq. mm FRLS PVC insulated copper conductor single core cable for loop earthing as required. (Recommended Material : Polycab, RR Kabel, V Guard, Havells)	m	30		
3	Wiring for circuit/ submain wiring alongwith earth wire with the following sizes of FRLS PVC insulated copper conductor, single core cable in surface/ recessed medium class PVC conduit as required.(Recommended Material : RR Kabel/National/Ralison/RKG/Finolex/Polycab / Havells)				
	a) 2 X 1.5 sq. mm + 1 X 1.5 sq. mm earth wire	m	12		
	b) 2 X 2.5 sq. mm + 1 X 2.5 sq. mm earth wire	m	60		
4	Supplying and fixing of following sizes of medium class PVC conduit (ISI brand) along with accessories in surface/recess including cutting the wall and making good the same in case of recessed conduit as required.				
	a) 25 mm	m	12		
5	S/F light plug point modular type accessories : Supplying and fixing suitable size GI box with modular plate and cover in front on surface or in recess, including providing and fixing 3 pin 5/6 amps modular socket outlet and 5/6 amps modular switch, connection,painting etc as required,	Each	12		
6	S/F Power plug point with modular type switch : Supplying and fixing suitable size GI box with modular plate and cover in front on surface or in recess, including providing and fixing 6 pin 15/16 and 15/16 amps modular switch, connection,painting etc as required.	Each	3		

SCHEDULE V - B					
Sub:	Setting-up of AMRIT Pharmacy Outlet at NIMHANS, BENGALURU				
Site Location	Existing HLL Lifecare Centre, OPD, NIMHANS, BENGALURU, KARNATAKA				
Item no.	Specification	Unit	Quantity	Rate in Rs.	Amount in Rs.
8	S/F 20A SPN MCB industrial socket outlet : Supplying and fixing 20 A, 240 V, SPN Industrial type socket outlet, with 2 pole and earth, metal enclosed plug top alongwith 20 A, "C" curve, SP, MCB, in sheet steel enclosure, on surface or in recess, with chained metal cover for the socket out let and complete with connections, testing and commissioning etc. as required.	Each	1		
9	S/F Modular boxes, base & cover plate : Supplying and fixing 1 or 2 module (75 mmx75 mm),GI box along with modular base, cover plate for modular switches in recess etc as required.				
a)	RJ-45 socket outlet	Each	6		
10	Supplying and drawing of UTP 4 pair CAT 6 LAN Cable in the existing surface/ recessed Steel/ PVC conduit as required. 1 run of cable	Each	90		
	MCCB, MCB & DB'S				
11	Supplying and fixing following way, horizontal type three pole and neutral, sheet steel, MCB distribution board, 230 V, on surface/ recess, complete with tinned copper bus bar, neutral bus bar, earth bar, din bar, interconnections, powder painted including earthing etc. as required. 4 way (4 + 12), Double door	Each	1		
12	S/F 'C' series, MCB : Supplying and fixing 5 amps to 32 amps rating, 240/415 volts, "C" curve, miniature circuit breaker suitable for inductive load of following poles in the existing MCB DB complete with connections, testing and commissioning etc. as required.				
a.	Single pole	Each	12		
13	Supplying and fixing following rating, four pole, (three phase and neutral), 415 V, residual current circuit breaker (RCCB), having a sensitivity current 30 mA in the existing MCB DB complete with connections, testing and commissioning etc. as required. 63A	Each	1		
14	Supplying and fixing Cable End Box (Loose wire box)(IP 43) suitable for following triple pole and neutral, sheet steel, MCB distribution board, 415 V, on surface/ recess, complete with testing and commissioning etc. as required. For 4 way, Double door TPN MCBDB	Each	1		
	LIGHT /FAN FITTINGS				

SCHEDULE V - B					
Sub:	Setting-up of AMRIT Pharmacy Outlet at NIMHANS, BENGALURU				
Site Location	Existing HLL Lifecare Centre, OPD, NIMHANS, BENGALURU, KARNATAKA				
Item no.	Specification	Unit	Quantity	Rate in Rs.	Amount in Rs.
15	Supply, installation, testing and commissioning of the following types of light fittings with all accessories on false ceiling, true ceiling or wall as directed and giving connections with 16/0.20 mm 3 core PVC insulated and sheathed round copper conductor flex wire or extending the original wiring and giving connections as required. All recessed type fixtures are to be supported independently with chains or GI wire anchored to the ceiling with anchoring bolt of necessary size. All loose wires above the false ceiling are to be neatly concealed by flexible metal/pvc conduits.(cost to include lamps & all consumables also)				
	a. 15W 4000k LED luminaire with High translucent diffuser gives soft glare free light & complete with electronic driver including all required mounting accessories complete.(Havells DIVA (RECESS) - 15W or equivalent)	Each	4		
	b. 1x18W T8 slim type tube fitting with decorative end caps. (Havells , Philips, Bajaj or equivalent)	Each	4		
	c. 2 x 36 W CFL Square type (600 x 600mm) decorative recessed fitting complete with all accessories (Make : Bajaj BMLA 101 CFL)	Each	2		
	d. Supply, Installation, testing and commissioning of wall mount fan (400mm sweep), adjustable speed . min 60 degree oscillation, swing, Adjustable upward and downward tilt mechanism, Protective Guard, Including connections with 1.5 sq. mm FRLS PVC insulated, copper conductor, single core cable, mounting accessories, etc. as required. It shall be double ball bearing type. (Make : USHA, Crompton , Havells)	Nos.	2		
METERING					
21	Supply, Installation, testing & commissioning of 3 phase 4 wire electronic type energy meter with LCD display with battery back up, class 1.00 CT with inbuilt CT. The whole unit to be mounted on suitable metal enclosure (powder coated with locking arrangement, seperate enclosure for incoming and outgoing) with 3 Nos. HRC fuses, Neutral Link and all connections complete.	Set	1		
CABLE / EARTHING					
16	Earthing with G.I. earth pipe 4.5 meter long, 40 mm dia including accessories, and providing masonry enclosure with cover plate having locking arrangement and watering pipe etc. with charcoal/coke and salt as required.	Each	1		

SCHEDULE V - B

Sub:	Setting-up of AMRIT Pharmacy Outlet at NIMHANS, BENGALURU				
Site Location	Existing HLL Lifecare Centre, OPD, NIMHANS, BENGALURU, KARNATAKA				
Item no.	Specification	Unit	Quantity	Rate in Rs.	Amount in Rs.
17	Providing and fixing 4.00 mm dia copper wire on surface or in recess for loop earthing as required.	m	80		
18	Supply and laying of following size 1.1 KV grade XLPE insulated, PVC sheathed, armoured Aluminium conductor power cable conforming to IS 7098 (Part 1) amended upto date.(including termination on both ends, laying as per site condition) 4C x 10 Sq.mm	m	40		
CCTV-SECURITY SYSTEM					
	Supply ,Installation ,Testing & commissioning of the following items :				
19	Indoor IR Dome camera : 1/3" CCD or equiv, 1.0 lux,AWB / BLC / AGC , min 20m range, Built-in IR illumination, white color case, PAL-CE/FCC approved., make CP PLUS or equivalent	Nos.	6		
20	Outdoor IR Bullet camera : 1/3" CCD or equivalent, 1.0 lux,AWB / BLC / AGC , ,min 20m range,Built-in IR illumination, white color case, DC12V, PAL-CE/FCC approved., make CP Plus or equivalent	Nos.	2		
21	Power supply unit for above camera as specified by camera manufacturer -12VDC 10A	Nos.	1		
22	Digital Video Recorder : 8-Channel Embedded HD DVR, 400fps, Real-time, with 2 TB HDD and English OSD, 230VAC. Rate shall be inclusive of all accessories, termination of cables, etc complete.	Nos.	1		
23	21" LED Color Monitors. make (LG/Samsung)	Nos.	1		
24	Supply and Laying of RG-6 Coaxial video cable with ISI marked PVC conduit including terminations with suitable BNC, etc complete. Make: Technoflex/Neolex/Finolex	m	80		
C	CAPITAL ITEMS				
1	Desktop Computers (Server type) : Supply and Installation at site ,all in one Desktop Computer (Business PC)- Core i3, 4GB RAM, 1 TB, DVD RW, 19.5 " Screen,10/100/1000 Gigabyte LAN, Win 10 PRO down gradable to Windows 8.1, Wired keyboard and mouse ,2Years Warranty with WPS Office Version 10 or higher/Open Office preloaded. Recommended Make: HP, ASUS, DELL, ACER, LENOVO	Set	1		

SCHEDULE V - B

Sub:	Setting-up of AMRIT Pharmacy Outlet at NIMHANS, BENGALURU				
Site Location	Existing HLL Lifecare Centre, OPD, NIMHANS, BENGALURU, KARNATAKA				
Item no.	Specification	Unit	Quantity	Rate in Rs.	Amount in Rs.
2	<p>Desktop Computers (User type) : Supply and installation at site, all in one Desktop Computer (Business PC) - Intel Dual core CPU 3.2Ghz or higher, 4GB RAM, 500 GB HDD, DVD RW, 19.5" Screen,10/100/1000 Gigabyte LAN, Win 10 PRO downgradable to Windows 8.1, Wired keyboard and mouse ,2 Years Warranty with WPS Office Version 10 or higher/Open Office preloaded. Recommended Make: HP, ASUS, DELL, ACER, LENOVO</p>	Set	2		
3	<p>Monochrome Laser Printer: Supply and Installation at site Monochrome Laser Printer as per the following specifications: Print Resolution: 600 x 600 dpi, Print Speed: Up to 14 ppm (mono), Print Cartridge: HP LaserJet Print Cartridge Print Technology: Laserjet, Connectivity: Hi-speed USB 2.0 Supported Media Types: Paper, envelopes, labels, cardstock, transparencies, postcards, Functionality: Print Power Consumption: Maximum 250 Watts Model : HP 1020Plus or equivalent</p>	Set	1		
4	<p>Ink tank Multi functional Printer Supply and Installation at siteMulti functional Printer as per the following specifications: Ink tank Multi functional Printer, for Bill Printing cum Office use with Warranty period of one year. Print Technology: Inkjet, Connectivity: Hi-speed USB 2.0 Supported Media Types: Paper, envelopes, labels, cardstock, transparencies, postcards, Functionality: Print, Scan/Copy. Power Consumption: Maximum 250 Watts Recommended Make: EPSON M200/HP GT5810/Canon G2000</p>	Set	1		
5	<p>Domestic Refrigerators : Standard single door refrigerator of minimum 185 Litres capacity (~20 ltrs. Freezer capacity) , Free standing, BEE 3 star rated or more, Stabilizer free operation on 230V AC Supply, minimum 3 nos. adjustable racks, with suitable voltage stabilizer, Manufacturer Warranty : Min. 5 Years for Compressor, Min.1 year for product. Recommended Make: Samsung, LG, Godrej</p>	No.	1		
6	<p>8 Port Network Switch : Supply and Installation at site : 10/100 Mbps 8-Ports Gigabit Switch . (Make : D-Link DGS-1008A)</p>	Set	1		

SCHEDULE V - B

Sub:	Setting-up of AMRIT Pharmacy Outlet at NIMHANS, BENGALURU				
Site Location	Existing HLL Lifecare Centre, OPD, NIMHANS, BENGALURU, KARNATAKA				
Item no.	Specification	Unit	Quantity	Rate in Rs.	Amount in Rs.
7	Counter Height Stools : Supply and installation at site counter height stools of following specifications :Revolving adjustable Chrome plated steel body chairs with resistance to the corrosion. Cushion Seat with Lift mechanism for Adjustment of height. Minimum height 750mm before expansion. Medium Back rest and arm rest. Item shall be of reputed make.	Nos.	4.00		
8	Supply of CO2 type fire extinguisher of 4.5 kgs. Make SAFEX / MINIMAX / CEASEFIRE or equivalent	Nos.	1		
9	Supply of ABC Type fire extinguisher of 2 Kgs. Make SAFEX / MINIMAX / CEASEFIRE or equivalent	Nos.	1		

SCHEDULE V - B					
Sub:	Setting-up of AMRIT Pharmacy Outlet at NIMHANS, BENGALURU				
Site Location	Existing HLL Lifecare Centre, OPD, NIMHANS, BENGALURU, KARNATAKA				
Item no.	Specification	Unit	Quantity	Rate in Rs.	Amount in Rs.
	MISCELLANEOUS:				
10	Supply and Installation of backlit flex board of approved size and design. The board shall be fabricated out of of GI metal fixed on MS angle supports fastened to wall/structure. Including electrical fittings, connections, all accessories, necessary coat of primer and enamel paint, complete. (size shall vary as per approved design and site conditions and will be paid as actuals)	Sq.m	2.00		
11	Supply of pedal type Dustbin : Polypropylene (PP) material, 7 ltr capacity minimum.	Nos.	2.00		
12	Cash Counting Machine cum Fake Note Detector Make : Optimus-Model No.OLC 04 or equivalent	each	1.00		
13	Cash Safe (Coffer) Volume. 14 L Min WallThickness: 2.5 mm min for body and 5 mm min for door Recommended Make: Godrej make, Model No. Premium Coffer BRN (Item Code: SEBP 1112) or equivalent (only manual locking system)	each	1.00		
14	3KVA UPS SYSTEM SIT of 3 KVA Online UPS Systems of the following specifications :- True on - line 3 KVA UPS system. Inversion shall be Microprocessor controlled with instantaneous sine wave Control using IGBT. UPS shall have standard display features, alarms, safeties, etc Input Voltage range : A.C 235 V (+15% to -20%), 1 phase Input Frequency : 50 HZ (+/- 3HZ) Power Factor : 0.8 or above. THD : less than 5% ; Ripple Voltage in battery terminal : less than 2% DC Voltage Minimum Back up time : Continuous 60 Mins at full load Rectifier shall be Full wave Type (Shall fully meet the specified input power requirements) Battery Type : SMF	Job	1.00		

SCHEDULE V - B

Sub:	Setting-up of AMRIT Pharmacy Outlet at NIMHANS, BENGALURU				
Site Location	Existing HLL Lifecare Centre, OPD, NIMHANS, BENGALURU, KARNATAKA				
Item no.	Specification	Unit	Quantity	Rate in Rs.	Amount in Rs.
15	Water Dispenser: Supply and Installation at Site Water Dispenser as per the following specification : Capable of dispensing Hot, normal and cold water, Power: rating 500 watts; Operating Voltage: 230 volts, with Heating Capacity: 5 liters/hour, storage compartment, auto-shut off, minimum year manufacturer warranty. Make : Voltas Mini Magic Pure-F or equivalent	Set	1.00		
Total Amount for Schedule V-B in INR					
Applicable Taxes in INR					
Total for Schedule V-B in INR					

SCHEDULE VI

DRAWINGS

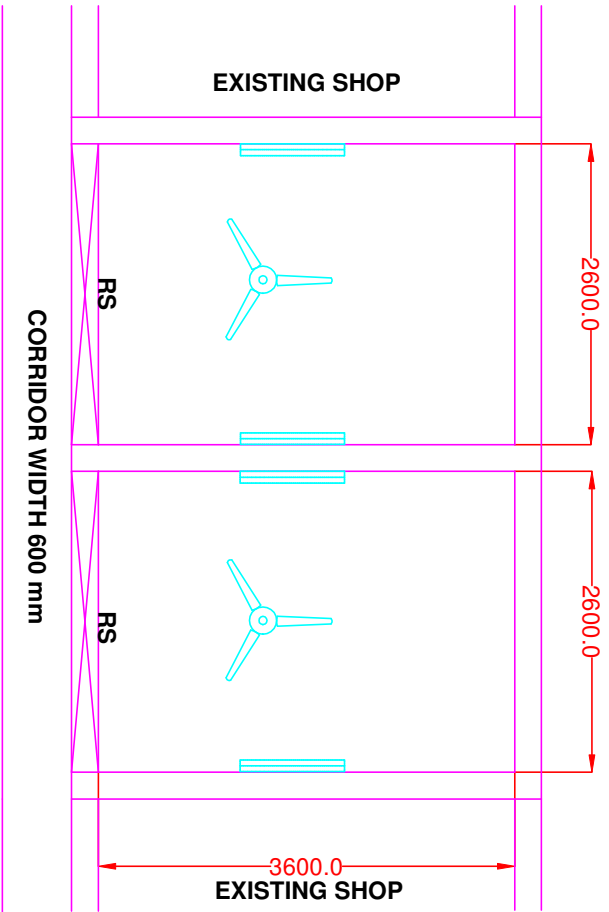

EXISTING LAYOUT

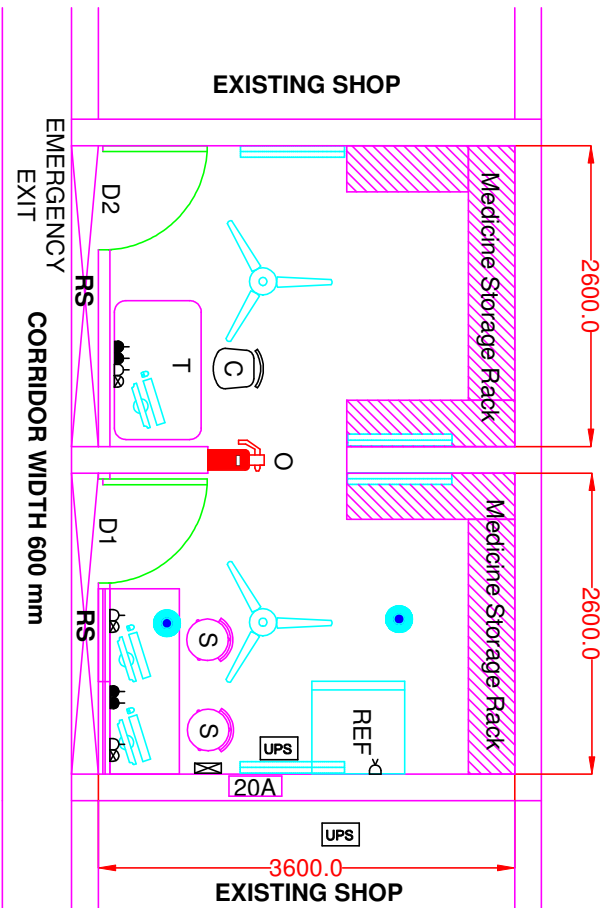

PROPOSED LAYOUT

Details	
•	6/5 A UPS Power Point (2.5 Sq MM Wirefor P,N&E)
-D	6/5 A Normal Power Point (1.5 Sq MM Wire for P,N&E)
×D	15 A Normal Power Point (4 Sq MM Wire for P,N&E)
20 A	Power Point for A/C. Metal Clad (Mains) for A/C 4 Sq MM Wire for P, N & E
Ⓐ	Net Work Point (RJ 45 Data Output)
•	1 x 15 W LED Round Type Light Fitting - UPS Supply
Ⓔ	Wall Mounted Fan 450 mm Sweep
ⓧ	Distribution Board-Power
UPS	UPS Position
🔥	2 Kg Fire Extinguisher - ABC Type

Details	
D 1	Single Swing Door W 1000 x H 2100 mm
D 2	Single Swing Door W 1000 x H 2100 mm
RS	Rolling Shutter W 2500 x H 3000 mm
RS 2	Rolling Shutter W 3000 x H 3000 mm
O	Wall Opening W 1500 x H 2100 mm
C1 & C2	Dispensing Counters, W 900 mm Each
REF	Refrigerator Position
S	Counter Height Stool
C	Computer Chair
T	Table

All Dimensions are in Millimeter

PLACE: NIMHANS, BANGALORE	HLL Lifecare Limited Thiruvananthapuram	AREA 18.72 Sq. M
DRAWN BY: SARATHI	TITLE:- LAYOUT FOR AMRIT PHARMACY AT NIMHANS, BANGALORE	DRG NO: HLL-PRO-RBD-AP-013
CHECKED BY: ARUN		SHEET NO : 01 OF 01
APPROVED BY:		REV:-00 DATE:- 03.01.2018
DATE: 03-01-2018		DATE:- 03.01.2018
SCALE: NTS		
ALL DIMENSIONS ARE IN MILLIMETER		

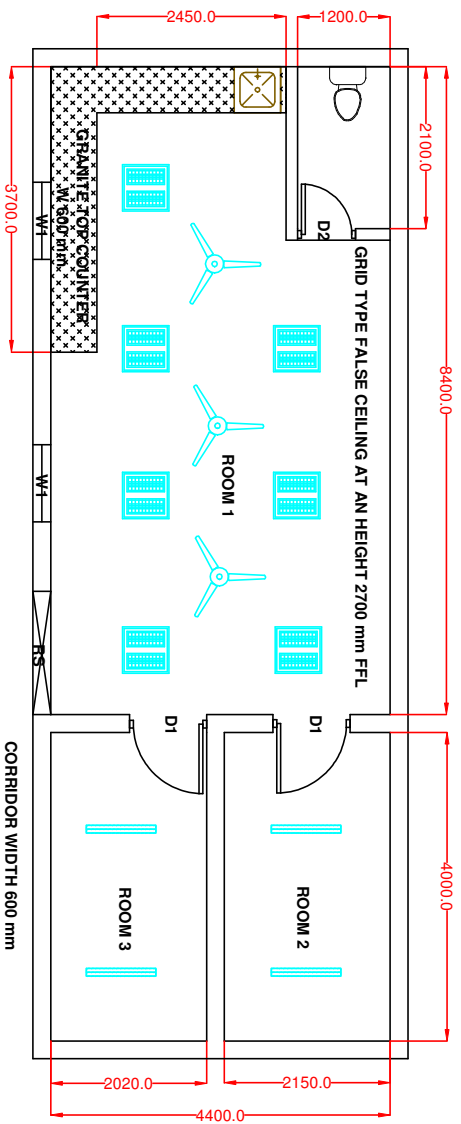

Details	
D 1	Single Swing Door W 1000 x H 2100 mm
D 2	Single Swing Door W 750 x H 2100 mm
RS	Rolling Shutter W 2500 x H 3000 mm
SD	Sliding Door Width 1000 mm
F/P	Full Partition as per Schedule
C1&C2	Dispensing Counters, W 900 mm Each
REF	Refrigerator Position
S	Counter Height Stool
T	Table

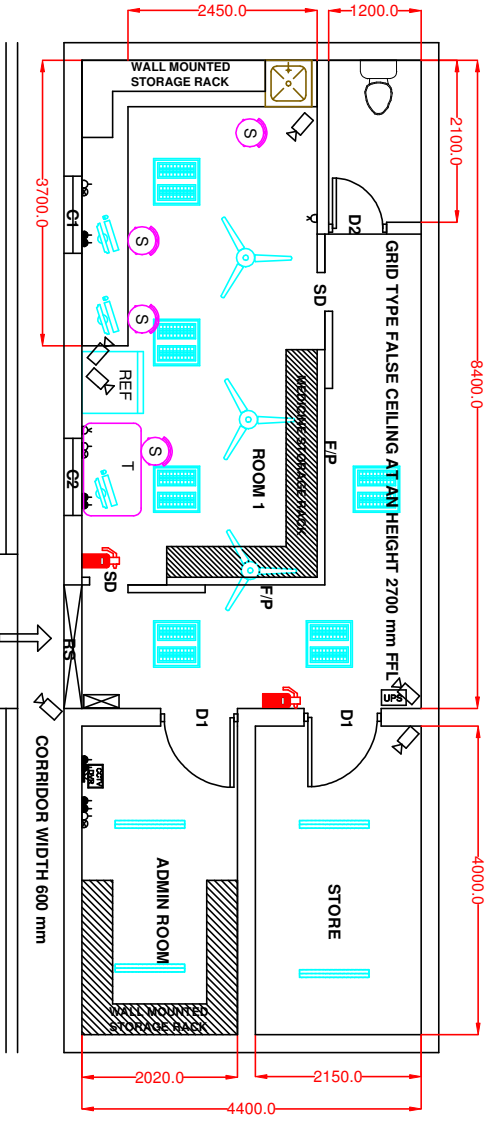

Details	
▲	6/5 A UPS Power Point (2.5 Sq MM Wire/P N&E)
-D	6/5 A Normal Power Point (1.5 Sq MM Wire for P,N&E)
-Q	15 A Normal Power Point (4 Sq MM Wire for P,N&E)
20 A	Power Point for A/C, Metal Clad (Main) for A/C 4 Sq MM Wire for P, N & E
Ⓐ	Net Work Point (RJ 45 Data Output)
Ⓛ	1 x 15 W LED Round Type Light Fitting - UPS Supply
Ⓜ	Wall Mounted Fan 450 mm Sweep
Ⓝ	Distribution Board-Power (Additional)
Ⓢ	UPS Position
Ⓡ	2 Kg Fire Extinguisher - ABC Type
Ⓢ	CCTV/Camera

PROPOSED LAYOUT

All Dimensions are in Millimeter

PLACE: NIMHANS, BANGALORE	AREA 54.56 Sq. M
DRAWN BY: SARATH	<p>HLL Lifecare Limited Thiruvananthapuram</p>
CHECKED BY: ARUN	
DATE: 03-01-2018	<p>LAYOUT FOR AMRIT PHARMACY AT NIMHANS, BANGALORE</p>
SCALE: NTS	DRG NO: HLL-PRO-RBD-AP-016
SHEET NO : 01 OF 01	