

ASSEMBLY VIEW
FOR A&B -TYPE

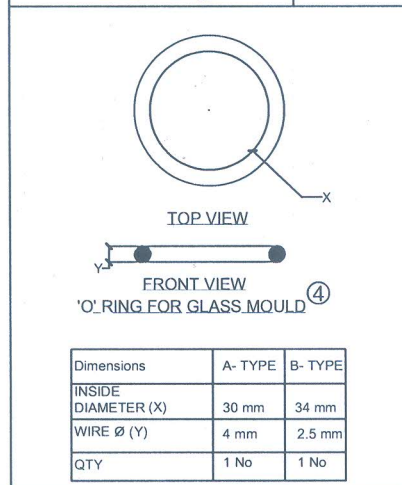

Dimensions	A- TYPE	B- TYPE
INSIDE DIAMETER (X)	30 mm	34 mm
WIRE Ø (Y)	4 mm	2.5 mm
QTY	1 No	1 No

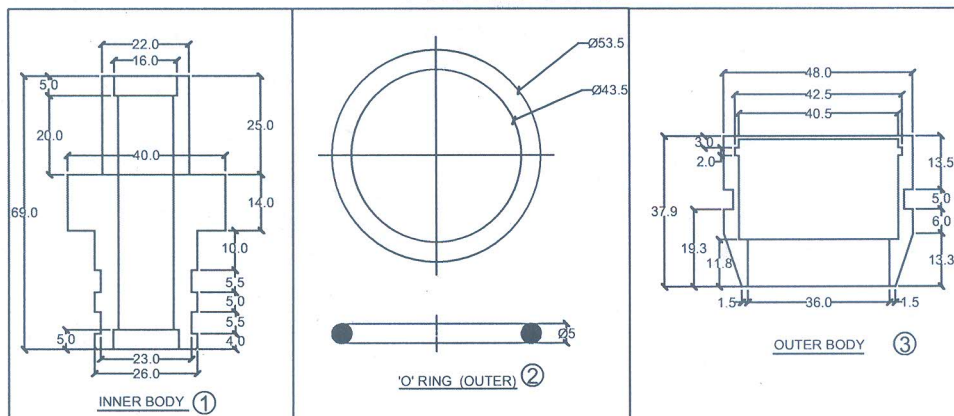
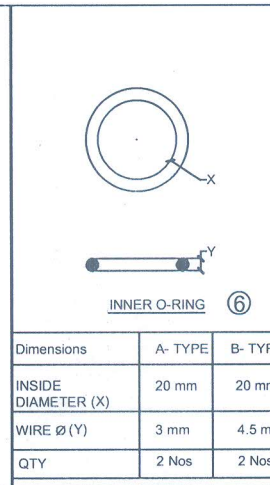
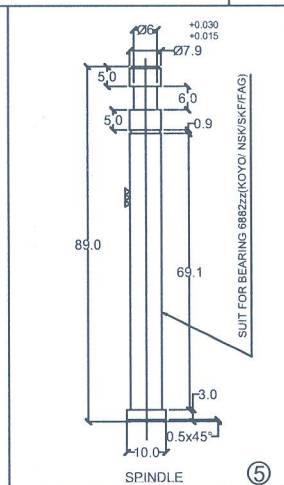

Dimensions	A- TYPE	B- TYPE
INSIDE DIAMETER (X)	20 mm	20 mm
WIRE Ø (Y)	3 mm	4.5 mm
QTY	2 Nos	2 Nos

PART NO	DESCRIPTION	MATERIAL	QTY.	REMARKS
1	INNER BODY	NYLON 66 Grade.virgin	1No.	
2	'O' RING (OUTER)	P.U. RUBBER	1No.	HARDNESS:- 65-70 SHORE A
3	OUTER BODY	NYLON 66 Grade.virgin	1No.	
4	'O' RING FOR GLASS MOULD	SILICON RUBBER	1No.	Hardness:-32 to 34 shore A
5	SPINDLE	AISI 316L (IS 1570-07Cr19Ni9Mo2Ti28)	1No.	
6	INNER O-RING	SILICON RUBBER	2Nos.	Hardness:-32 to 34 shore A
7	External circlip (shaft dia=8)	SS 304 Treated	1No.	(Type-A Heavy series) IS -3075-1965
8	Internal circlip (dia=40)	SS 304 Treated	1No.	IS -3075-1965
9	Bearing no. L-1680D	Silicon rubber sealed	2Nos.	Make:- NMB SINGAPORE.(688 2RH)

MATERIAL: _	HLL LIFECARE LIMITED THIRUVANANTHAPURAM-5		NO.OFF.
DRAWN BY:-	RAJKIRAN.D	TITLE:- MOULD HOLDER FOR BTADLCDM (FOR A & B -TYPE)	
CHECKED BY:-	<i>[Signature]</i>	Drg.no:- HLL- CED-B2- 027-00	
APPROVED BY:-	<i>[Signature]</i>		
DATE:	22-12-2015	SHEET NO. 1 OF 1	
SCALE:			
ALL DIMENSIONS ARE IN M.M		REV:- 00 DATE:-	