

20.11.2015

Amendment - I

**AMENDMENT TO TENDER FOR OFFICE INTERIOR FURNISHING WORKS
AT IVC, CHENGALPATTU**

Ref: 1. Tender No: HBL/TD/IVC/ADMIN/OFF_FURNISH/15-16 dated 31/10/2015

2. Pre-Bid MOM dated 05.11.2015

With reference to the Tender Enquiry Document and Pre-bid MOM for Office Interior Furnishing Works at IVC, Chengalpattu, the following amendment may please be noted,

1. **BOQ page No:13/57 Point No:5.7** Vinyl Graphics - Basic Price Per Sqft shall be considered as Rs.150/-
2. **BOQ page No:16/57 Point No:8.1** Wash Basin -Model shall be as follows,
Parryware - CELICO C848C or C848F.
Jaguar - JDS-WHT-25935 or JDS-WHT-25909.
3. **BOQ page No:17/57 Point No:8.5** Pillar Cock
Since, the FLR 5016 Model is stopped by Jaguar, Model No FLR 5015 shall be considered.
4. Projector Screen – Make: DRAPER / DALITE
5. AV Concept Schematics (Board room AV Layout, Conference hall AV Layout & Training Room AV Layout are Enclosed)
6. Cable cubby - Make : Magnum / Kramer
7. Equipment rack - Make : Valrack / Rittel

All other terms & conditions, specifications, drawing etc., shall remain same as per the tender No: HBL/TD/IVC/ADMIN/OFF_FURNISH/15-16 dated 31/10/2015 and the minutes of pre-bid meeting dated 05.11.2015.

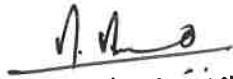

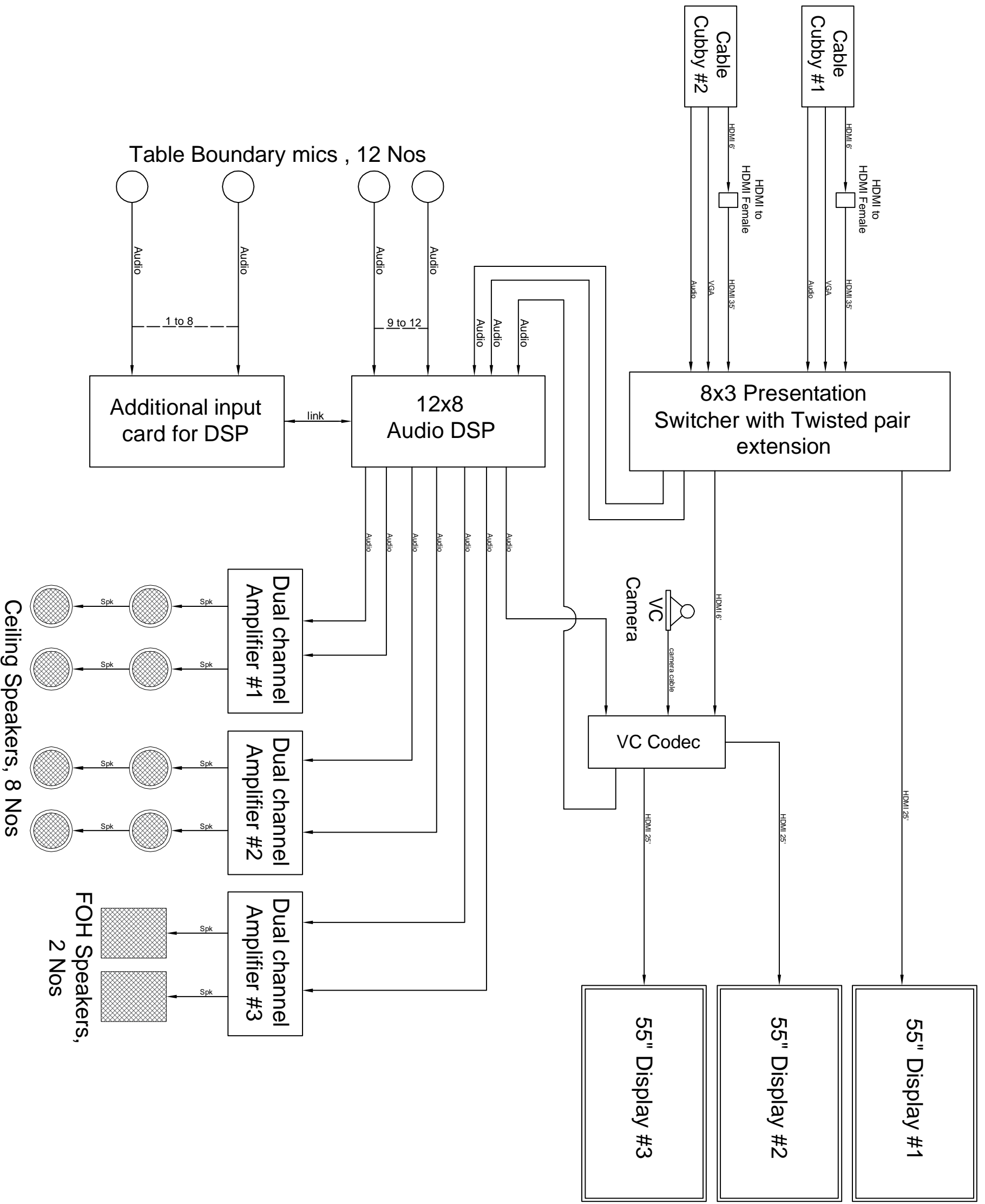
(S. S. Srinivas
20/11/15.)
Authorized Signatory

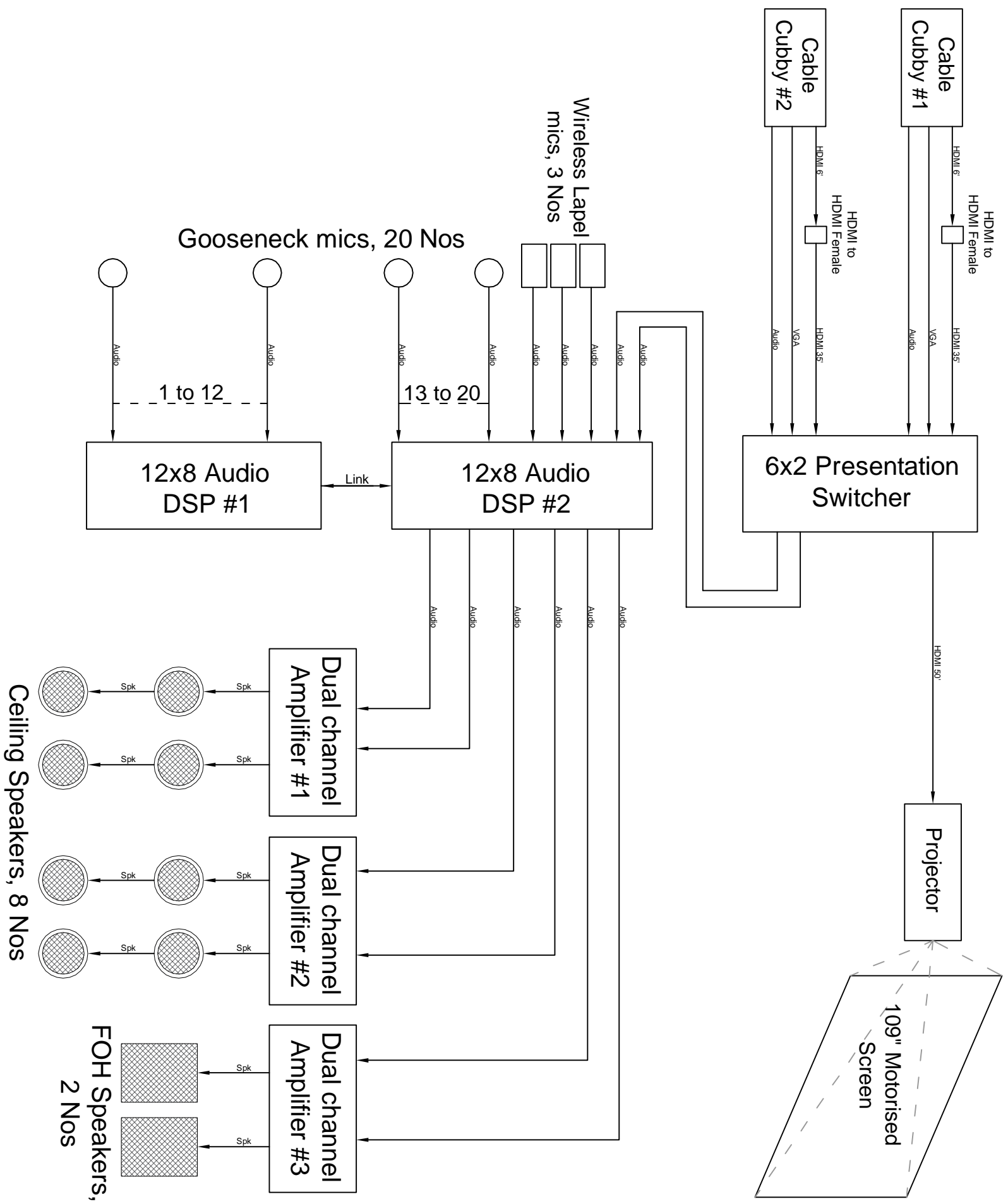

File name :		HILL BIOTECH LIMITED	
Originated from Dwg. No :		Tidal Biopark Campus, (Medicell #013, 014, 015) CSIR Road, Taramani, Chennai-600 113, Tel : 91 44-22542955	
Project :		INTEGRATED VACCINES COMPLEX, CHENGALPATTU HLL BIOTECH LIMITED	
Description:		BOARD ROOM - AV SCHEMATICS LAYOUT	
Drawn	Date	Name	
Checked	21.03.2015	SAI.PRADEESH	
Approved	23.03.2015	CEO (HLL)	
Scale-NTS	Units : mm	Size : A1	
Drawing no:	HBL/VC/ADMIN/AV/002		Rev.
			00

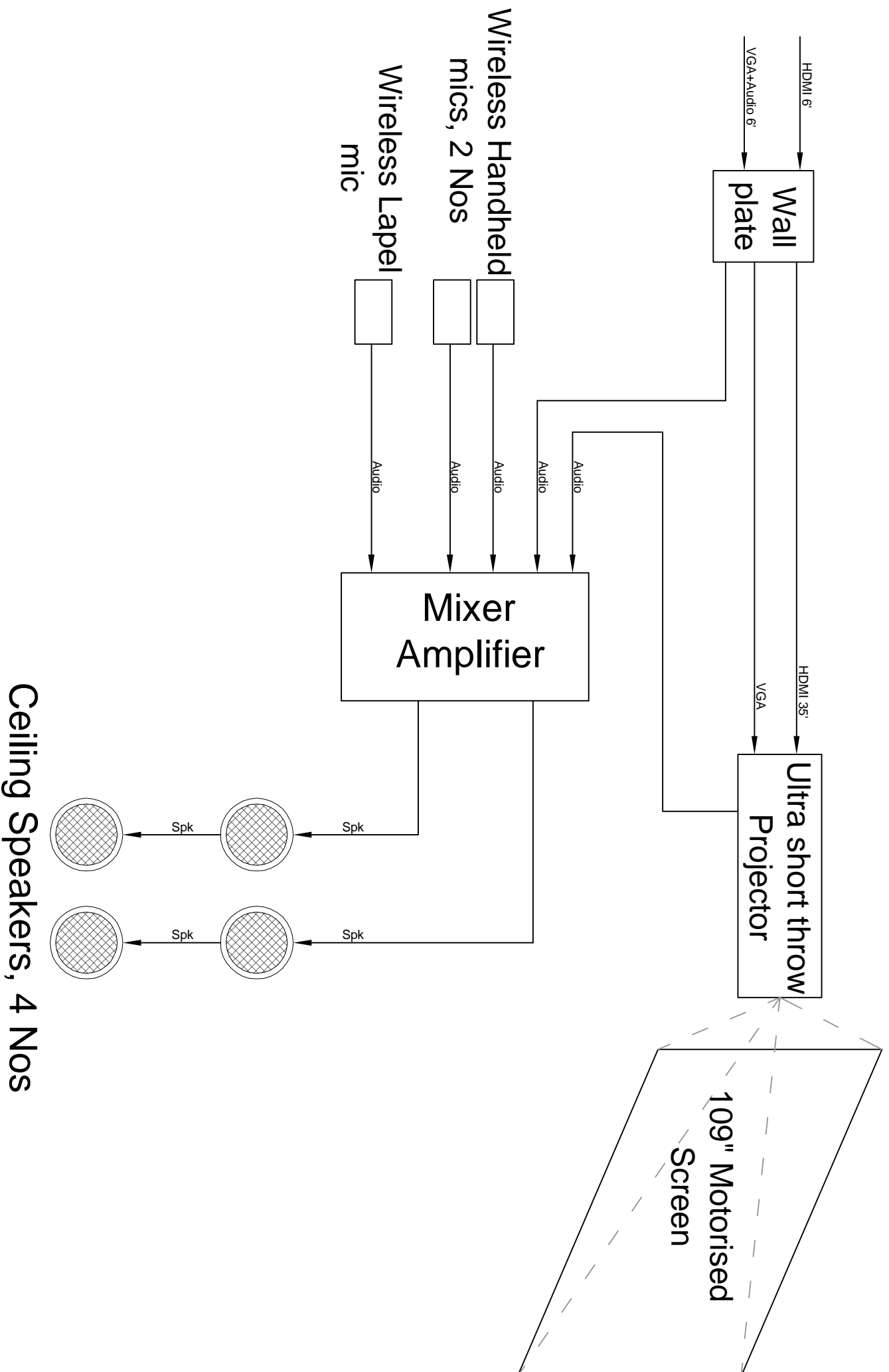

File name :			
Originated from Drg. No :			
Project:		HILL BIOTECH LIMITED	
Description:		INTEGRATED VACCINES COMPLEX, CHENGALPATTU HILL BIOTECH LIMITED	
HILL BIOTECH LIMITED Tidal Biopark, Campus (Module #013, 014, 015) CSR Road, Taramani, Chennai-600 113, Tel : 91 44-22542965		Drawn: 18.03.2016 Checked: 27.03.2016 Approved: 28.03.2016 Scale: NTS Drawing no: HBL/VC/ADMIN/AV/001	
CONFERENCE ROOM - AV SCHEMATICS LAYOUT		Name: HILL BIOTECH LIMITED Size: A1 Rev: 00	



Ceiling Speakers, 4 Nos

File name :			
Originated From Dwg. No :			
Project:		HLL BIOTECH LIMITED	
Description:		Trecel Biopark Campus, (Module #013, 014, 015) CSJR Road, Taramani, Chennai-600 113, Tel : 91 44-22542965	
Drawn	18.09.2015	DM (PROJECTS)	
Checked	21.09.2015	SM (PROJECTS)	
Approved	23.09.2015	CEO (HLL)	
Scale-NTS	Units : mm	Size : A1	
Drawing no:		HBL/VC/ADMIN/AV/003	
		Rev.	00

TRAINING ROOM - AV SCHEMATICS LAYOUT