

TENDER DOCUMENT

SUPPLY, INSTALLATION & INTEGRATION OF PANEL BOARD , CONTROLS INCLUDING MACHINE WIRING FOR THREE LINE SQUARE PACKING MACHINE AT HLL, PFT

**HLL LIFECARE LTD,
CENTRAL ENGINEERING DIVISION
PEROORKADA FACTORY,
THIRUVANANTHAPURAM – 695 005,
KERALA, INDIA.**

PHN: ++91 471 2437270

FAX: ++91 471 2432647

**IFB No.: HLL/CED/PFT/3LINE PKG/ELECTFN/2016
DATE : 12-03-2016**

HLL LIFECARE LIMITED
(A Government of India Enterprise)
Central Engineering Division, Peroorkada. P.O,
Thiruvananthapuram – 695005,
Kerala, India
Phn: 0471- 2433374,2437270, 2435090
Fax No. (0471) 2432647

INVITATION FOR BIDS (IFB)

IFB No : HLL/CED/PFT/3LINEPKG/ELECTFN/2016
DATE : 12-03-2016

HLL Lifecare Limited (HLL) invites sealed and super scribed bids from competent and experienced eligible Suppliers/Contractors for the supply of following item in connection with the fabrication of three line packing machines at our factory in Kerala.

Sl. No	Brief Description of Item/Work	Quantity	EMD
1	SUPPLY , INSTALLATION & INTEGRATION OF PANEL BOARD ,CONTROLS INCLUDING MACHINE WIRING FOR THREE LINE SQUARE PACKING MACHINE AS PER DRAWING, SPECIFICATIONS AND SCHEDULE AT HLL,CED, PEROORKADA,THIRUVANANTHAPURAM	As per schedule of items	Rs.2000/-

I. INSTRUCTION TO BIDDERS:

1. A complete set of bid documents can be had from the Office of the Deputy Chief Engineer(CED), Central Engineering Division, HLL Lifecare Limited, Peroorkada Factory, Thiruvananthapuram – 695 005, Kerala, India during office hours on any working day on submission of written application.

The Tender Documents can also be downloaded from our Website www.lifecarehll.com from the date of issue of tender document. Tender forms shall be filled in ink or typed. No tender filled in pencil shall be considered. The tenderer shall sign and seal the form at each page and at the end, in token of acceptance of all the terms and conditions of the tender. Any subsequent changes/amendments will be published only in our website .

2. The scheduled date for issue, receipt and opening of bids is as follows.

- a) Date of issue of tender document - 12-03-2016
- b) Last date and time for receipt of bids - 21-03-2016 up to 15.00 Hrs.
- c) Date and time of opening of bids - 21-03-2016 , 15.30 Hrs.
- d) Address for communication, receipt and place of opening of bids:

Deputy Chief Engineer(CED),
Central Engineering Division,
HLL Lifecare Limited (A Government of India Enterprise),
Peroorkada, Thiruvananthapuram – 695005,
Kerala State, India
Ph: (++91 471) 2433374,2437270 –501,502
Tele Fax: (++ 91 471) 2432647
E-mail:rajeevrv@lifecarehll.com, krknair@lifecarehll.com

3. The Bid must include the following information;

- a. Enquiry No.
- b. Promised Delivery Schedule for each item.
- c. Acceptance Form (Schedule III)
- d. Price Schedule in Format For Quoting (Schedule IV)
- e. All other documents/certificate/information as specified in the bid document.

4. In addition to the invitation for bids, the bidding documents include the following schedules.

- Schedule I - Instruction to the Bidders
- Schedule II - Conditions of Contract
- Schedule III - Acceptance Form
- Schedule IV- Format for quoting

5. The completed and sealed bid documents should be submitted to Associate Vice President (CED), in the above address. The outer cover should bear the Enquiry No, closing date and General description of item tendered, and the words "DO NOT OPEN BEFORE" 15.30 Hrs (IST) on ----- (Indicate the Closing Date).
6. Bids will be opened in the presence of bidders' representative(s) who choose to attend on the specified date and time, at the office of HLL at the address given in Clause 2 (d) above.
7. In the event of the date specified for bid receipt and opening being declared as a closed holiday for purchaser's office, the due date for submission of bids and opening of bids will be the following working day at the appointed times.
8. The purchaser may, at its discretion, extend this deadline for submission of bids by amending the Bid Documents or any other reasons, in which case all rights and obligations of the Purchaser and Bidders previously subject to the deadline will thereafter be subject to the deadline as extended.
9. Purchaser will not be held responsible for the postal delay, if any, in the delivery of the bidding document or the non-receipt of the same. Bids sent by Telex/Fax/Telegraph will not be accepted.
10. HLL reserves the right to club or split the items of works, change the qualifying criteria at their discretion and to reject or cancel the Invitation for bids without assigning any reason thereof.

ASSOCIATE VICE PRESIDENT (CED)

SCHEDULE II

CONDITIONS OF CONTRACT

1) PRICE

The price quoted should be inclusive of Basic Price, all applicable taxes and duties including VAT, Entry tax, Octroi & other levies, P&F charges, loading and unloading charges, insurance, etc. The Supplier should pay entry taxes, as applicable and should be included in the offer.

The Format for Quoting (Schedule IV) shall be suitably filled as applicable. The quoted rate shall be valid for a period of 90days from the tender submission date. No price escalation and no change in terms and conditions will be allowed on any ground till the order is completely executed.

2) TAXES/DUTIES/LEVIES

The supplier shall be entirely responsible for all taxes including entry tax, duties, license fees, etc. incurred until successful completion of contract. All central, state, municipal taxes, duties and levies payable shall be shown by the bidder separately in the Bid. The Purchaser will issue necessary 'C' Form, if required.

3) COMPLETION TIME

- a. The work should be delivered within **three weeks** from the date of issuing the Letter of Intent or Supply Order.
- b. The quantity mentioned herein are approximate requirement with staggered delivery.
- c. In case less or more quantity is required the suppliers should be prepared to effect supply at short notice on the same terms and conditions.

4) GUARANTEE PERIOD

The Guarantee against any possible manufacturing defects shall be given for a period of 18 months from the date of supply and inspection of the item at HLL site or 12 months from the date of supply, whichever is earlier. The supplier has to provide 10% performance bank guarantee valid for guarantee period as per tender.

5) LIQUIDATED DAMAGES FOR DELAYS

If the material is not supplied to the purchaser within the time stipulated in the Order, Purchaser may at their option, either (1) recover from the Supplier liquidated damages at the rate of 0.5 % of the total purchase order value for every week of delay, subject to a maximum of 7.5 % of the total purchase order value, or (2) at the risk and cost of the Supplier and without prejudice to the other remedies/rights as per the Contract, terminate the order wholly or partially and complete it themselves or reassign it to other Suppliers.

6) PAYMENT TERMS

- a) 90% of the executed value of the work will be released after successful completion of the installation , integration & commissioning of the three line packing machine.
- a) Balance 10% shall be released against a Performance guarantee valid for a period of one year from the date of the issue of final acceptance certificate of the entire system.

7. SETTLEMENT OF DISPUTES

Any disputes or differences or questions or claims arising under or relating to or touching this agreement shall be referred for arbitration to a Sole Arbitrator under the provisions of the Arbitration and Conciliation Act 1996 or any statutory modification or re-enactment thereof for the time be in force. The award passed by the arbitrator shall be final and binding on the parties hereto.

The contract shall be deemed to have been concluded at Thiruvananthapuram, Kerala and suits and proceedings, if any, shall be only in the courts of competent jurisdiction in Thiruvananthapuram.

The venue of arbitration shall be the place from where the contract is issued.

The company reserves the right to club or split the items of supply and reject or cancel the Invitation for bids without assigning any reason thereof.

SCHEDULE III
ACCEPTANCE FORM

(To be submitted in the letter pad of the firm indicating full name and address, telephone & fax numbers etc.)

From

To

Associate Vice President (CED)
Central Engineering Division,
HLL Lifecare Limited (A Government of India Enterprise),
PB No 2, Peroorkada, Thiruvananthapuram – 695005,
Kerala State, India
Ph: (++91 471) 2433374,2437270 –501,502
Tele Fax: (++ 91 471) 2432647
E-mail: snair@lifecarehll.com, rajeevrv@lifecarehll.com

Dear Sir,

I / We, hereby offer to supply materials as detailed in schedule here to or such portion thereof as you may specify in the acceptance of Bid at the price given in the price bid and agree to hold this offer open till 90 days after the date of bid opening prescribed by the purchaser. I/We have understood the terms and conditions mentioned in the invitation for bid and Conditions of Contract furnished by you and have thoroughly examined the specifications and drawings in the bid document hereto and are fully aware of the nature of the scope of supply and my/our offer is to comply strictly in accordance with the requirement and the terms and conditions mentioned above. I/We have understood that the PURCHASER is the sole owner of the technology, equipment, specification and drawings given along with the bidding documents. I/we here by assure that the above information will be kept confidential and will not be used for any other purpose or will not be transferred to third party.

Yours faithfully,

SIGNATURE OF THE BIDDER

SCHEDULE IV

SCHEDULE OF WORK					
Sub:	Supply & Installation of Panel Board ,Controls including machine wiring for Three Line Square Packing Machine				
SI No	Item/Work Description	Unit	Quantity	Rate in Rs	Amount in Rs
A	Supply & Installation of following items as per specifications for Three Line Square Packing Machine(Wiring should be as per IS 732 & earthing of panel should be as per IS 3043/IEC 60364 , Panel should be as per IS 8437(Part 1&2) / IEC 60479-1&2 , IS 60529/IEC 60529 , IS 9409/IEC 61140 ,IS 9676, IS 5216 with Test Certificates)				
1	Supply of Panel Board as per drawing no.HLL-CED-FR-143-00 with size with 2 mm Powder Coated CRCA Sheet Make :Rittal/Schneider/ABB Terminal blocks, Illumination lamps required with the panel.	Nos.	3.00		
a)	Installation & Integration charges for the above	Nos.	3.00		
2	Supply of PLC 12-24 V DC(E3X-NA 11 type) (As per IEC 61131-3/IEC 61499/IEC 61508 with test and calibration certificates) Make : Omron	set	3.00		
a)	Installation & Integration charges for the above	set	3.00		
3	Supply of HMI (7" Colour Display) Touch Screen Type, HMI PV Component graphic terminal, illuminated PBs , Terminal block (As per IEC 60297/IEC 60571/IEC 60812/IEC 61508/IEC 61131-1/IEC UL 61010-1/IEC 608NF & IS 2500 with Test & calibration certificates) Make:SiemensAllen Bradley/Mitsubishi/L&T	set	3.00		
a)	Installation & Integration charges for the above	set	3.00		
4	Supply of Main MCB (As per IS 13032 , IS 13947/IEC 60947-5-2 , IS 9409/IEC 61140 , IS 8623 (part 1 to 3)/IEC 60439(1to 3), IS 8504/IEC 60216-4-2 , IS 60715/IEC 60715 ,IS 60898/IEC 60898 , IS 60947(Part 1&2)/IEC 60947, IS 10118(Part 1 to 4) , IS 60529/IEC 60529 , IS 9676) with Test Certificates.				
a)	20 A, 4 Pole, 450 V MCCB, CAT A, MAKE: L&T/LS/Hager	Nos.	3.00		
b)	Installation & Integration charges for the above	Nos.	3.00		
5)	Supply of MCB (As per IS 13032 , IS 13947/IEC 60947-5-2 , IS 9409/IEC 61140 , IS 8623 (part 1 to 3)/IEC 60439(1to 3), IS 8504/IEC 60216-4-2 , IS 60715/IEC 60715 ,IS 60898/IEC 60898 , IS 60947(Part 1&2)/IEC 60947, IS 10118(Part 1 to 4) , IS 60529/IEC 60529 , IS 9676) with Test Certificates				
a)	20 A , 3 Pole,230 V MAKE:L&T/LS/Hager	Nos.	3.00		
b)	10A, 2 Pole ,230 V MAKE:L&T/Siemens/LS/Hager	Nos.	6.00		
c)	6A, 2 Pole ,230 V AC MAKE:L&T/Siemens/LS/Hager	Nos.	6.00		
d)	Installation charges for the above	Nos.	15.00		

SI No	Item/Work Description	Unit	Quantity	Rate in Rs	Amount in Rs
6)	Supply of Emergency Push Button Stop (with alarm) (As per IEC 60947-5-5) with Test Certificates				
a)	Emergency Push Button Stop (with alarm) 5A, 230 V, 22.5MM OD MAKE:ABB/EAO/Schneider	set	3.00		
b)	Installation & Integration charges for the above	set	3.00		
7)	Supply of illuminated Control Button (As per IEC 60947-5-1/ IEC 60947-5-2 & IS 60529/IEC 60529 with Test Certificates) MAKE:ABB/Schneider	Nos.	9.00		
a)	Installation charges for the above	Nos.	9.00		
8)	Supply of Power Supply(24 V DC) (As per IEC 61850-3/IEC 60950-1) with Test & Calibration Certificates MAKE: Meanwell/GE/MTL	Nos.	3.00		
a)	Installation & Integration charges for the above	Nos.	3.00		
9)	Supply of Variable Frequency Drive (VFD) (As per IEC 60034-2-3) with input choke with Test & Calibration Certificates				
a)	1 HP VFD , 3Ph with input choke MAKE:ABB/Allen Bradley/GE/Moeller/Vagon	Nos.	3.00		
b)	Installation & Integration charges for the above	Nos.	3.00		
10)	Supply of illuminated Push Button (As per IS/IEC 60947-5-1/IEC61058-1) with Test Certificates				
a)	Illuminated Push Button (Red & Green) MAKE:ABB/Schneider	Nos/ Each	6.00		
b)	Installation & Integration charges for the above	Nos.	6.00		
11)	Supply of Solenoid Valve Control (As per IS/IEC 61508/IEC 61511) with Test Certificates				
a)	Festo -ADN-32-20-1-P-A-52 Type	set	3.00		
b)	Festo – MFH-5-1/8-9982-ED23 type	set	9.00		
c)	Installation charges for the above	set	12.00		
12)	Supply and Installation of Air Regulators (As per IS/IEC 61508/IEC 61511) with Test Certificates				
a)	Air Regulators(10 bar pressure) MAKE:Festo	set	9.00		
b)	Installation & Integration charges for the above	set	9.00		
13)	Supply and Installation of Cooling Fan Blower (As per relevent IS/IEC Standards) Reputed make				
a)	Voltage-230 V, Frequency - 50Hz, P=28 W, Flow Rate =1.7m ³ /min, X=19.5mm.	Nos	3.00		
b)	Installation & Integration charges for the above	Nos	3.00		

SI No	Item/Work Description	Unit	Quantity	Rate in Rs	Amount in Rs
14)	Supply and Installation of Up-Mould Temperature Controller/ Under- Mould Temperature Controller Digital PID controller (As per relevent IS/IEC Standards)				
a)	Range 50° -1300°C, PID Controller , Multi range- RTD , Thermo Couple , Output SSR 100/240 V AC, Autonics TC4S type.	Set	6.00		
b)	Installation & Integration charges for the above	Nos	6.00		
15)	Supply and Installation of Heater Cartridge (As per relevent IS/IEC Standards) Make :Elmech				
a)	600W/700W, High Density Cartridge Heater in Stainless Steel housing length 230mm- Ø 18.75mm 2 lead wires (Each 300mm long, Fibre Glass Insulated 1.5sq mm, 240V,700W) with suitable heat resistant washers ment for continuous operation.	Nos	6.00		
b)	Installation & Integration charges for the above	Nos	6.00		
16)	Supply and Installation of Pneumatic Dispenser (As per relevent IS/IEC Standards) Make :Festo				
a)	Pressure-3 Bar, Capacity -200-100ml/shot, stroke rate 0-60 stroke/min, connections/ point-6 nos	Nos	3.00		
b)	Installation & Integration charges for the above	Nos	3.00		
17)	Supply and Installation of Counter (As per relevent IS/IEC Standards)				
a)	Autonics FX6Y-1	set	6.00		
b)	Installation & Integration charges for the above	Nos	6.00		
18)	Supply and Installation of Proximity Switch(Sensor) (As per relevent IS/IEC Standards)				
a)	Frequency Response Max= 50Hz, Sensing Range Max= 4mm, Sensor Input=Inductive, Supply Voltage DC= 24 V, PNP Make : Autonics/Omron	Nos	12.00		
b)	Installation & Integration charges for the above	Nos	12.00		
19)	Supply and Installation of Limit Switch (As per relevent IS/IEC Standards)				
a)	240 VAC, 0.6A Make: Schneider	Nos	9.00		
b)	Installation & Integration charges for the above	Nos	9.00		
20)	Supply and Installation of Digital Pressure Switch (As per relevent IS/IEC Standards)				
a)	Dual display to check (Current value and Set value), 3 colour display , copy functions of setting details, 3-Mode settings, size 30X25.5 mm Make: Festo.	Set	3.00		
b)	Installation & Integration charges for the above	Nos	3.00		
21)	Supply and Installation of of Upmould/Under mould heater sensor (As per relevent IS/IEC Standards)				
	Flat Sensor(Button Type) Make:Autonics/Omron	set	6.00		
b)	Installation & Integration charges for the above	Nos	6.00		

SI No	Item/Work Description	Unit	Quantity	Rate in Rs	Amount in Rs
22)	Supply and Installation of Proximity Switch (Sensor) 3 Pieced for pump (silicon oil) (As per relevent IS/IEC Standards)				
a)	10-30V DC , 8 mm PNP , Max load-300 mA Make:Autonics/Omron	Nos	12.00		
b)	Installation & Integration charges for the above	Nos	9.00		
23)	Supply and Installation of Rotary Switches (On/Off) (As per relevent IS/IEC Standards)Make:L&T/Kaycel				
a)	415 V ,15 A	Nos	12.00		
b)	Installation & Integration charges for the above	Nos	12.00		
24)	Supply and Installation of Jam sensor with PLC (As per relevent IS/IEC Standards)				
	24 V DC Fiber Optic sensor unit with amplifier.PLC 12-24 V DC(E3X-NA 11 type).Fiber Optic Photo Electric Switch Amplifier Set with LED Bar Display of Light Levels, NPN Open Collector output and suitable for 10 to 30 VDC Operation.Make:Omron	Set	3.00		
b)	Installation & Integration charges for the above	Nos	3.00		
25)	Supply and Installation of No-Product sensor (As per relevent IS/IEC Standards)				
a)	24 V DC Fiber optic sensor unit,M4, Through Beam,Pre-wired w/ 2m Cable , E32-TC-200 type. Make:Omron	Set	3.00		
b)	Installation & Integration charges for the above	Nos	3.00		
26)	Supply and Installation of Slit Cutter waste collection motor (As per relevent IS/IEC Standards) Make:Reputed make				
a)	240 V , 0.06 μ F,0.08 A,50 Hz	Nos	3.00		
b)	Installation charges for the above	Nos	3.00		
27)	Supply and installation of Relay DC type (As per relevent IS/IEC Standards)				
	24V DC, MY4N Make: Omron	Nos	15.00		
b)	Installation & Integration charges for the above	Nos	15.00		
28)	Supply and installation of Relay AC type (As per relevent IS/IEC Standards)				
a)	230 V AC Make: Omron	Nos	9.00		
b)	Installation & Integration charges for the above	Nos	9.00		
29)	Supply and installation of proximity sensor (As per relevent IS/IEC Standards)				
a)	230 V AC Make: Radix/Omron	Nos	12.00		
b)	Installation & Integration charges for the above	Nos	9.00		

SI No	Item/Work Description	Unit	Quantity	Rate in Rs	Amount in Rs
30)	Supply and Installation of Toggle Switch (As per relevent IS/IEC Standards)				
a)	230 V AC Make: Schneider	Nos	9.00		
b)	Installation & Integration charges for the above	Nos	9.00		
31)	Supply of Cables and Accessories (As Per IS 649/ IEC 60227, IS 1255, IS 10810 (Part 0 to 64), IEC 60189 (1 to 3), IEC 60304, IEC 60028, IEC 60332-3, IEC 60227(1 to 5), IEC 60719, IEC 60228.) with test certificates				
a)	5x2.5 sq mm Cu cable MAKE:Lapkabel	Mtr	150.00		
b)	3x2.5 sq mm Cu cable MAKE:Lapkabel	Mtr	150.00		
c)	3x1.5 sq mm Cu cable MAKE:Lapkabel	Mtr	150.00		
d)	3 C X 4 Sq mm Heat Resistant Cable MAKE:Lapkabel	Mtr	60.00		
e)	Sensor cable(Fiber class) 3 core Make:Lapkabel	Mtr	90.00		
d)	Installation & Integration charges for the above	Mtr	600.00		
32)	Supply of Junction Boxes (As per IS 60529/IEC 60529) With test certificates MAKE:Reputed make	Nos.	6.00		
a)	Installation & Integration charges for the above	Nos.	6.00		
33)	Supply of Other Panel Accessories				
a)	Filter 6" MAKE:Reputed make	Nos.	3.00		
b)	Plug & Socket MAKE:Havels/Anchor	Nos.	6.00		
c)	Panel Light , MAKE:HavelsPhilips/	Nos.	6.00		
d)	Junction Box MAKE:Rittal	Nos.	6.00		
e)	Installation & Integration charges for the above	Nos.	21.00		
34)	Supply of Earthing Materials for Machine Earthing (As per relevent IS/IEC Standards)				
a)	single stranded Cu flat (5x5) earthing of machine with double earthing to all the motors, Juction boxes and Panels. MAKE:Reputed make	Mtr	40.00		
b)	Panel Door Earthing(Braided Cu cable) MAKE:Reputed make	Mtr	9.00		
c)	Installation & Integration charges for the above	Mtr	49.00		
35)	Supply and installation of slip ring(As per relevent IS/IEC Standards)				
a)	Slip ring 230 v AC , 10A	Nos	6.00		
36)	Supply and Installation of Timer				
a)	Timer digital ,Make:Autonics	set	3.00		
	Total Amount in Rs				
	Taxes if any				
	GROSS AMOUNT IN RS				

(RUPEES IN WORDS)

I hereby agree to supply/execute the item/work specified at the above quoted rate/amount.

SUPPLIER/CONTRACTOR

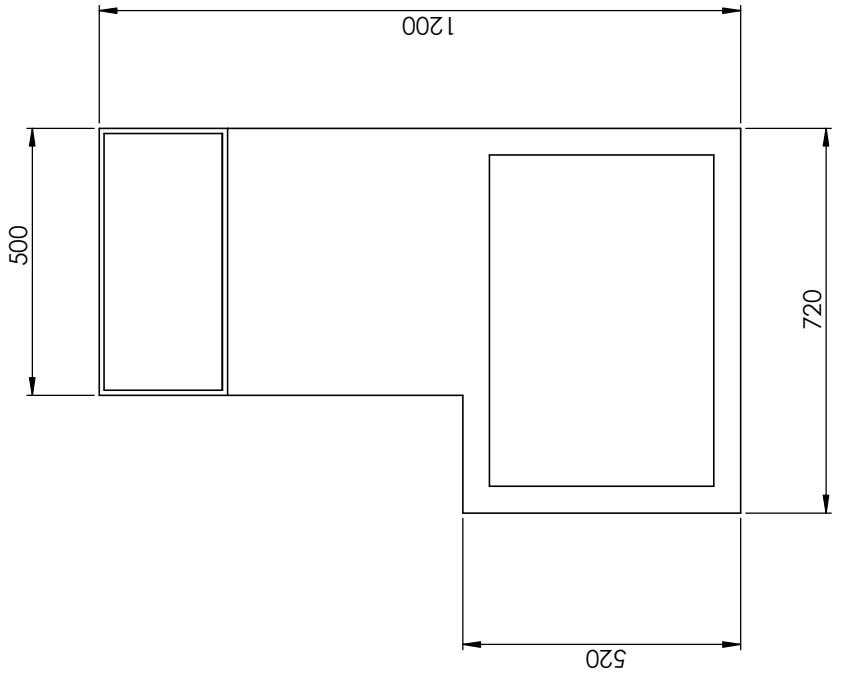
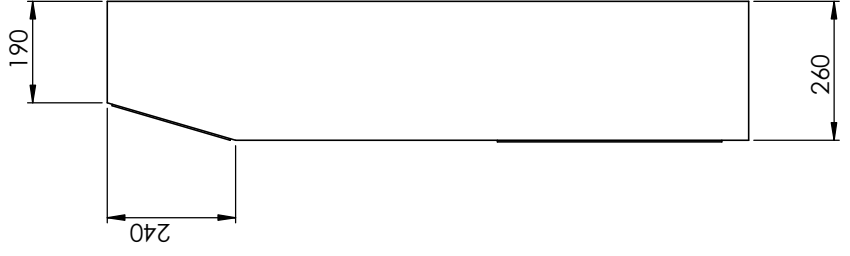
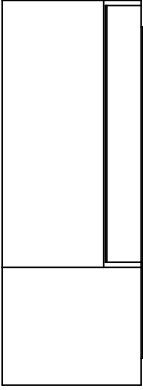
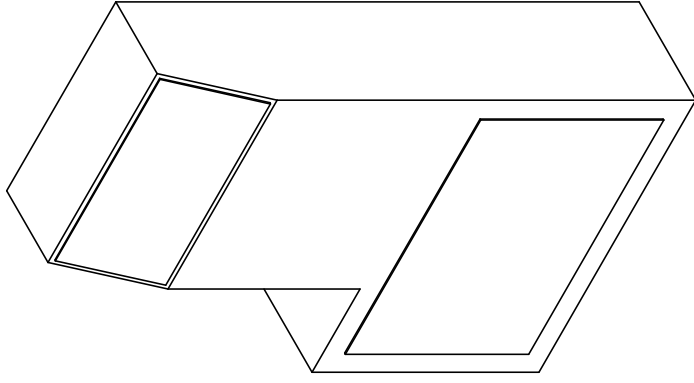

MATERIAL 14 SWG CRCA SHEET	HLL LIFECARE LTD THIRUVANANTHAPURAM-5	QTY 01 NO
DRAWN BY SARATH	TITLE PANEL BOARD ASSEMBLY	
CHECKED BY RAJIRAN		
APPROVED BY KRK		
DATE 11.03.2016	DRG NO:	
SCALE NITS	HLL-CED-F2-143-00	
ALL DIMENSIONS ARE IN MM		

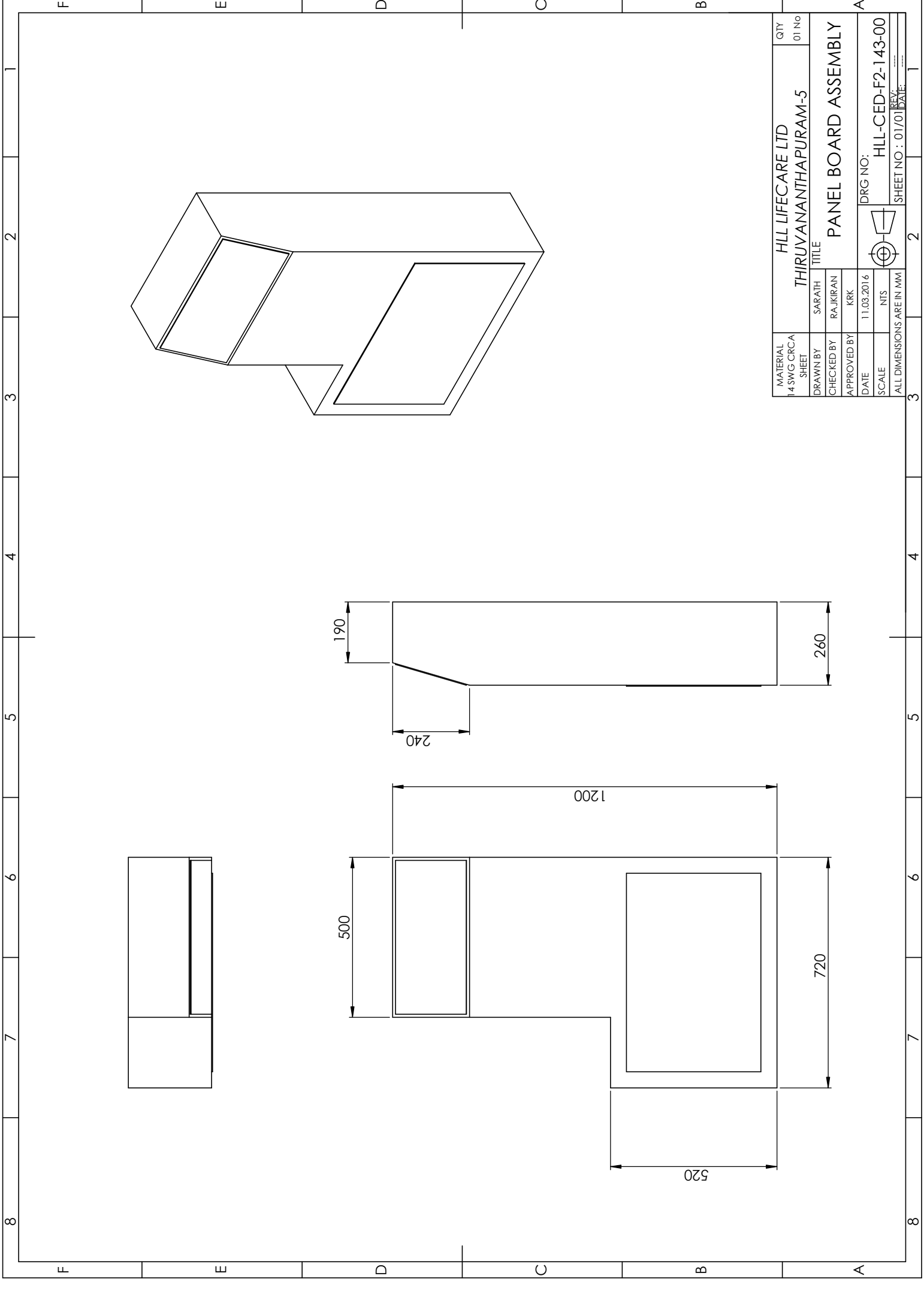
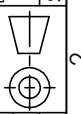

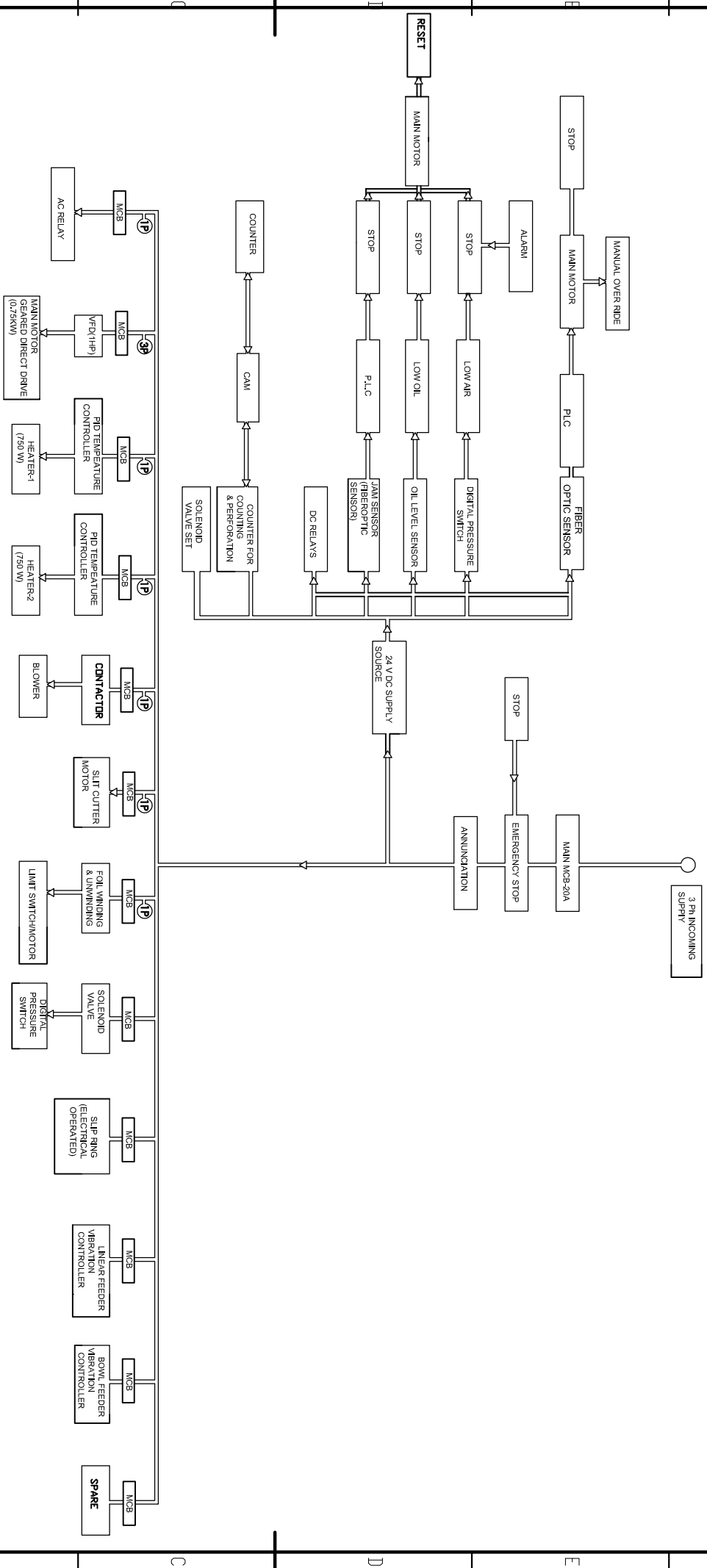

DIMENSIONS OPERATED SPECIFIED:		FINISH		FEATURE AND BREAK SHARP EDGES	
DIMENSIONS ARE IN MILLIMETERS					
TOLERANCES					
LINEAR					
ANGULAR					
NAME	SIGNATURE	DATE		TITLE:	
BRAWN	RAKIBRAUD	17-11-2015		ELECTRICAL DETAILS DF PACKING MACHINE	DO NOT SCALE DRAWING
CHK'D					REVISION
APP'VD					
WF'G					
QA					
MATERIAL:			DWG NO.	SCALE: 1:1	
WEIGHT:				SHEET 1 OF 1	

ELECTRICAL DETAILS
DF PACKING MACHINE

A3