

TENDER DOCUMENT

Construction of Smart Village Office at Nagaroor, Thiruvananthapuram

e-Tendering



PROJECTS DIVISION

HLL Lifecare Limited

(A Government of India Enterprise)

Corporate Head Office, Poojappura.P.O,
Thiruvananthapuram – 695012, Kerala, India

Phn: 0471- 2354949, 2775588

December 2018

CONTENTS

SI No	Part No.	Description	Page Nos.
1	Part I	INSTRUCTIONS TO THE BIDDERS	8
2	Part II	GENERAL CONDITIONS OF CONTRACT	22
3	Part III	SPECIAL CONDITIONS OF CONTRACT	69
4	Part IV	CONTRACT DATA	80
5	Part V	TECHNICAL SPECIFICATIONS	82
6	Part VI	FORMS AND DECLARATIONS	88
7	Part VII	DRAWINGS	97

HLL LIFECARE LIMITED
(A Government of India Enterprise)
Projects Division
Corporate Head Office, Poojappura.P.O,
Thiruvananthapuram – 695012, Kerala, India
Phn: 0471- 2354949, 2775588

NOTICE INVITING TENDER (NIT)

e- Government Procurement (e-GP)

IFB No: HLL/CHO/PROJ/EXT/SVO/NAGARROOR/2018-19

Dated: 21-12-2018

HLL Lifecare Limited (HLL), a Government of India Enterprise, on being selected as Project Management Consultant (PMC) for the construction of Smart Village Offices at various locations in Thiruvananthapuram, invites online bids from the eligible, competent and experienced Suppliers/Contractors who are capable to do the following work meeting the requirements as per our tender.

1	Name of Work	Construction of SMART village office at Nagaroor in Thiruvananthapuram
2	Location of Work	Nagaroor, Chirayankeezhu Taluk Thiruvananthapuram
3	Estimated Cost of the Work	Rs. 38 Lakhs
4	Brief description of work	Civil Construction works, Electrical Works, Workstation and other Furniture Works.
5	Bid Security	Rs 50,000/-
6	Bid submission fee (tender fee)	Rs. 2500/- + GST @ 12% = Rs 2800/-
7	Period of completion	100 days
8	Eligibility criteria for Bidders	As per Clause 1.3 ITB
9	Last date and time for online submission of bids	04-01-2019 at 15:00 hrs
10	Date and time of opening of tender	07-01-2019 at 15:00 hrs

1. Bid documents including the Bill of Quantities (BoQ) can be downloaded free of cost from the e-Government Procurement (e-GP) Website www.etenders.kerala.gov.in. All bid documents are to be submitted online only and in the designated cover(s)/ envelope(s) on the e-GP website. Tenders/ bids shall be accepted only through online mode on the e-GP website and no manual submission of the same shall be entertained. Late tenders will not be accepted. A bid submission fee shall be remitted online during the time of bid submission.

2. The bids shall be opened online on **05-01-2019** at the **Office of the Senior Manager (Projects), Project Division, HLL Lifecare Ltd, Poojappura** in the presence of the Bidders / their authorized representatives who wish to attend at the above address. If the tender opening date happens to be on a holiday or non-working day due to any other valid reason, the tender opening process will be done on the next working day at same time and place.
3. Online Tenders/ bids are to be accompanied with a preliminary agreement executed in Kerala stamp paper worth Rs.200/-. Tenders / bids received online without the details mentioned in clause 4.3 of Instructions to the Bidders (ITB) will not be considered and shall be summarily rejected.
4. More details can be had from the Office of the Senior Manager (Projects), Project Division, HLL Lifecare Ltd, Corporate Head Office, Poojappura.P.O P.O., Thiruvananthapuram – 695012, Kerala, India during working hours. The Tender Inviting Authority/Project Management Consultant (PMC) shall not be responsible for any failure, malfunction or breakdown of the electronic system while downloading or uploading the documents by the Bidder during the e-procurement process.
5. Details required for e-payment (Details of bank account having core banking facility and e-mail address of the bidder) shall be furnished along with the tender. Tenders not accompanied by these details will be rejected. All subsequent Government orders connected to tenders and any revision in the rates of taxes would also be applicable to this tender.
6. HLL reserves the right to accept or reject any or all tenders without assigning any reason thereof.
7. General Tender Terms & Conditions for e-Procurement is as given below:

This tender is an e-Tender and is being published online for the **“Construction of SMART Village Office at Nagaroor in Thiruvananthapuram”**. The tender is invited in 2 cover system from the registered and eligible firms through e-procurement portal of Government of Kerala (<https://www.etenders.kerala.gov.in>). Prospective bidders willing to participate in this tender shall necessarily register themselves with above mentioned e-procurement portal.

The tender timeline is available in the critical date section of this tender published in www.etenders.kerala.gov.in.

7.1 Online Bidder registration process:

Bidders should have a Class II or above Digital Signature Certificate (DSC) to be procured from any Registration Authorities (RA) under the Certifying Agency of India. Details of RAs will be available on www.cca.gov.in. Once, the DSC is obtained, bidders have to register on www.etenders.kerala.gov.in website for participating in this tender. Website registration is a one-time process without any registration fees. However, bidders have to procure DSC at their own cost.

Bidders may contact e-Procurement support desk of Kerala State IT Mission over telephone at 0471-2577088/188/388 or 0484-2336006, 2332262 or 0497-2764788, 2764188 or 0483-273294 or through email: etendershelp@kerala.gov.in or helpetender@gmail.com for assistance in this regard.

7.2 Online Tender Process:

The tender process shall consist of the following stages:

- i. Downloading of tender document: Tender document will be available for free download on www.etenders.kerala.gov.in, www.lifecarehll.com and Central Public Procurement Portal (www.eprocure.gov.in). However, tender document fees shall be payable at the time of bid submission as stipulated in this tender document.
- ii. Pre-bid meeting: Not Applicable for this tender
- iii. Publishing of Corrigendum: All corrigenda shall be published on www.etenders.kerala.gov.in, www.lifecarehll.com and Central Public Procurement Portal (www.eprocure.gov.in) and shall not be available elsewhere.
- iv. Bid submission: Bidders have to submit their bids along with supporting documents to support their eligibility, as required in this tender document on www.etenders.kerala.gov.in. No manual submission of bid is allowed and manual bids shall not be accepted under any circumstances.
- v. Opening of Technical Bid and Bidder short-listing: The technical bids will be opened, evaluated and shortlisted as per the eligibility and technical qualifications. All documents in support of technical qualifications shall be submitted (online). Failure to submit the documents online will attract disqualification. Bids shortlisted by this process will be taken up for opening the financial bid.
- vi. Opening of Financial Bids: Bids of the qualified bidder's shall only be considered for opening and evaluation of the financial bid on the date and time mentioned in critical date's section.

8. Documents Comprising Bid:

- i. The First Stage (Pre-Qualification or Technical Cover based on 2 cover tender system):

Pre-Qualification or Technical proposal shall contain the scanned copies of the following documents which every bidder has to upload:

1. Copy of Valid GST registration, EPF Registration Certificate and IT PAN Card details as per Clause 1.3.1.1 a of ITB
2. Work orders and Completion certificates in proof of experience as per Clause 1.3.1.2 of ITB
3. Work orders and Completion certificates in proof of experience in Government Departments works as per Clause 1.3.1.3 of ITB
4. Audited Balance sheets in proof for Average annual financial turn-over as per Clause 1.3.1.4 of ITB
5. FORM OF TENDER as per Part VI of Forms and Declarations
6. PRELIMINARY AGREEMENT FORMAT as per Part VI of Forms and Declarations
7. Integrity Pact as per the format in Part VI
8. Affidavit as per the format in Part VI
9. Requisition Form for e-Payment as per the format in Part VI
10. MSME/NSIC certificate if applicable

The department doesn't take any responsibility for any technical snag or failure that has taken place during document upload.

ii. The Second Stage (*Financial Cover or as per tender cover system*):

The Bidder shall complete the Price bid as per format given for download along with this tender.

Note: The blank price bid should be downloaded and saved on bidder's computer without changing file-name otherwise price bid will not get uploaded. The bidder should fill in the details in the same file and upload the same back to the website.

Fixed price: Prices quoted by the Bidder shall be fixed during the bidder's performance of the contract and not subject to variation on any account. A bid submitted with an adjustable/variable price quotation will be treated as non - responsive and rejected.

8 Tender Document Fees and Bid Security(EMD)

The Bidder shall pay, a tender document fees of **Rs. 2800/- (including GST @ 12%)** and Bid Security of **Rs. 50,000/-**. The Bid Security is required to protect the purchaser against risk of Bidder's conduct, which would warrant the forfeiture of security.

Online Payment modes: The tender document fees and Bid Security can be paid in the following manner through e-Payment facility provided by the e-Procurement system

State Bank of India Multi Option Payment System (SBI MOPS Gateway): Bidders are required to avail Internet Banking Facility in any of below banks for making tender remittances in e-Procurement System.

A) Internet Banking Options (Retail)			
1	Allahabad Bank	15	Karnataka Bank
2	Axis Bank	16	Karur Vysya Bank
3	Andhra Bank	17	Kotak Mahindra Bank
4	Bandan Bank	18	Lakshmi Vilas Bank
5	Bank of Bahrain and Kuwait	19	Mehsana Urban Co-op Bank
6	Bank of Baroda	20	NKGSB Co-operative Bank
7	Bank of India	21	Oriental Bank of Commerce
8	Bank of Maharashtra	22	Punjab and Maharashtra Cooperative Bank
9	Bassein Catholic Co-operative Bank	23	Punjab National Bank
10	BNP Paribas	24	Punjab and Sind Bank
11	Canara Bank	25	RBL Bank
12	Catholic Syrian Bank	26	Saraswat Cooperative Bank
13	Central Bank of India	27	ShamraoVithal Cooperative Bank
14	City Union Bank	28	South Indian Bank

29	Corporation Bank	43	Janata Sahakari Bank
30	Cosmos Bank	44	Standard Chartered Bank
31	DCB Bank	45	State Bank of India
32	Dena Bank	46	Syndicate Bank
33	Deutsche Bank	47	Tamilnad Mercantile Bank
34	Dhanalaxmi Bank	48	Tamilnadu Cooperative Bank
35	Federal Bank	49	The Kalyan Janata Sahakari Bank
36	HDFC Bank	50	TJSB Bank (Erstwhile Thane Janata Sahakari Bank)
37	ICICI Bank	51	UCO Bank
38	IDBI Bank	52	Union Bank of India
39	Indian Bank	53	United Bank of India
40	Indian Overseas Bank	54	Vijaya Bank
41	IndusInd Bank	55	YES Bank
42	Jammu & Kashmir Bank		

B) Internet Banking Options (Corporate)

1	Bank of Baroda	19	Karur Vysya Bank
2	Bank of India	20	Kotak Bank
3	Bank of Maharashtra	21	Laxmi Vilas Bank
4	BNP Paribas	22	Oriental Bank of Commerce
5	Canara Bank	23	Punjab & Maharashtra Coop Bank
6	Catholic Syrian Bank	24	Punjab & Sind Bank
7	City Union Bank	25	Punjab National Bank
8	Corporation Bank	26	RBL Bank
9	Cosmos Bank	27	Shamrao Vitthal Co-operative Bank
10	Deutsche Bank	28	South Indian Bank
11	Development Credit Bank	29	State Bank of India
12	Dhanalaxmi Bank	30	Syndicate Bank
13	Federal Bank	31	UCO Bank
14	HDFC Bank	32	Union Bank of India
15	ICICI Bank	33	UPPCL
16	Indian Overseas Bank	34	Vijaya Bank
17	JantaSahakari Bank	35	Axis Bank
18	Jammu & Kashmir Bank		

During the online bid submission process, bidder shall select *SBI MOPS* option and submit the page, to view the *Terms and Conditions* page. On further submitting the same, the e-Procurement system will re-direct the bidder to MOPS Gateway, where two options namely *SBI* and *Other Banks** will be shown.

Here, Bidder may proceed as per below:

a) *SBI Account Holders* shall click **SBI** option to with its Net Banking Facility., where bidder can enter their internet banking credentials and transfer the Tender Fee and EMD amount.

b) Other Bank Account Holders may click **Other Banks** option to view the bank selection page. Here, bidders can select from any of the 54 Banks to proceed with its Net Banking Facility, for remitting tender payments.

**Transaction Charges for Other Banks vide SBI Letter No. LHO/TVM/AC/2016-17/47 – 1% of transaction value subject to a minimum of Rs. 50/- and maximum of Rs. 150/-*

** Bidders who are using Other Banks option under SBI MOPS Payment Gateway, are advised by SBI to make online payment 72 hours in advance before tender closing time.*

Any transaction charges levied while using any of the above modes of online payment has be borne by the bidder. The supplier/contractor's bid will be evaluated only if payment status against bidder is showing "**Success**" during bid opening.

9 SUBMISSION PROCESS:

For submission of bids, all interested bidders have to register online as explained above in this document. After registration, bidders shall submit their Technical bid and Financial bid online on www.etenders.kerala.gov.in along with online payment of tender document fees and EMD.

Note:- It is necessary to click on "Freeze bid" link/ icon to complete the process of bid submission otherwise the bid will not get submitted online and the same shall not be available for viewing/ opening during bid opening process.

SENIOR MANAGER (PROJECTS)

Part I

INSTRUCTIONS TO THE BIDDERS (ITB)

1. GENERAL

1.1. Scope of the Bid:-

HLL Lifecare Limited (HLL), a Government of India Enterprise, on being selected as Project Management Consultant (PMC) for the construction of Smart Village Offices at various locations in Thiruvananthapuram, invites online bids from the eligible, competent and experienced Suppliers/Contractors who meet the eligibility criteria for the Work detailed in the Notice Inviting Tender (NIT).

1.1.1. Throughout these bidding documents:

- a. The terms 'in writing' means communicated in written form and delivered against receipt;
- b. except where the context requires otherwise, words indicating the singular also include the plural and words indicating the plural also include the singular; and any reference to masculine gender shall whenever required include feminine gender and vice versa.
- c. "day" means calendar day.
- d. The terms "bid" and "tender" and their derivatives "Bidder/tenderer, bid/tender, bidding/tendering etc.," are synonymous.
- e. "Project Management Consultant (PMC)" shall mean HLL Lifecare Limited (HLL) (Thiruvananthapuram) or its units thereof.
- f. "Client/Department" shall mean District collector, Thiruvananthapuram.
- g. Project Management Consultant (PMC) will carry out its functions and obligations for the client through Officers/Engineers who have been delegated powers for the same.
- h. Engineer-In-Charge', shall mean the Engineer appointed by the Project Management Consultant to supervise all activities of the project.
- i. The "Tender Inviting Authority", "Accepting Authority" and the "Agreement Authority" means the officer who has invited and received bids for the Work and has executed agreement for execution on behalf of the PMC. The Tender Inviting Authority, Accepting Authority and the Agreement Authority shall be one and the same person unless otherwise specified.
- j. `Contractor', shall mean the successful bidder whose tender has been accepted by the Project Management Consultant and to whom the order is placed by the Project Management Consultant and shall include his heirs, legal representatives, successors etc.
- k. "Contract Price" means price approved by the Project Management Consultant (PMC) after bidding and stated in the Letter of Acceptance and thereafter as adjusted in accordance with the provisions of the Contract.

1.1.2 The bid invited shall be of item rate contract.

1.1.3 The mode of this tender is e-tender.

1.2. Source of funds

1.2.1. The expenditure on this Work will be met from the Plan/Non plan allocation of State Government/Central Government funds/Funds allocated by National funding Agencies as mentioned in the Contract Data.

1.3. Eligible Bidders

1.3.1. A Bidder shall have the following eligibility to submit bids against this tender.

1.3.1.1. Bidder should have a valid Certificate of:

- a. GST registration
- b. EPF Registration Certificate
- c. IT PAN Card

Note: - Copy of valid certificates for the above shall be submitted in proof of the same

1.3.1.2. Bidders should have experience of having successfully completed within a period of last 5 years ending 30/11/2018 at least

- i. One similar work of value not less than Rs 30 Lakhs Or
- ii. Two similar works, each of value not less than Rs 22 Lakhs Or
- iii. Three similar works, each of value not less than Rs 15 Lakhs

Note: - Work orders and Completion certificates issued by the Client/Authority shall be submitted in proof of the same.

1.3.1.3. Bidder should have satisfactorily completed at least one work for any Central/State Government Departments or Central/State PSU's or local bodies in the last five years ending 30/11/2018.

Note: - Work orders and Completion certificates issued by the Client/Authority shall be submitted in proof of the same.

1.3.1.4 Average annual financial turnover of the bidder during the last 3 years, ending 31st March of the previous financial year, should be at least INR 20 Lakhs.

Note: - Enclose audited Balance sheets in proof for the above period

1.3.2. All Bidders are required to register in the e-procurement portal. The Bidder intending to participate in the bid is required to register in the e-tenders portal using his / her Login ID and attach his / her valid Digital Signature Certificate (DSC) to his/her unique Login ID. He / She have to submit the relevant information as asked for about the firm/contractor. The bidders, who submit their bids for this tender after digitally signing using their Digital Signature Certificate (DSC), accept that they have clearly understood and agreed the terms and conditions including all the Forms / Annexure of this tender.

1.3.3. Only those bidders having a valid and active registration, on the date of bid submission, shall submit bids online on the e-GP website.

- 1.3.4. Ineligible bidder or bidders who do not possess valid & active registration, on the date of bid submission, are strictly advised to refrain themselves from participating in this tender.
- 1.3.5. A firm/bidder shall submit only one bid in the same bidding process. A Bidder (either as a firm or as an individual or as a partner of a firm) who submits or participates in more than one bid will cause all the proposals in which the Bidder has participated to be disqualified.
- 1.3.6. Joint ventures or Consortiums of two or more registered contactors are not permitted.

1.4. Cost of Bidding

- 1.4.1. The bidder shall bear all costs associated with the preparation & submission of bids and site visits, and the Project Management Consultant (PMC) will in no case be responsible or liable for those costs, regardless of the conduct or outcome of the bidding process.
- 1.4.2. The tender document(s), may be downloaded free of cost from the e-Government Procurement (e-GP) website (www.etenders.kerala.gov.in). However a bid submission fee, as mentioned in the NIT, is required to be submitted along with the online bid.

1.5. Site Visit

- 1.5.1. The bidder is advised to visit and examine the Site of Works and its surroundings and obtain for itself on its own responsibility all information that may be necessary for preparing the bid and entering into a contract for construction of the Works. He shall examine the site condition and satisfy himself of the availability of materials at nearby places, difficulties which may arise during execution before submitting the bids. The costs of visiting the Site shall be at the bidder's own expense.
- 1.5.2. The bidder and any of his personnel or agents will be granted permission by the Project Management Consultant (PMC)/Client to enter upon its premises and lands for the purpose of such visit, but only upon the express condition that the bidder, his personnel or agents will release and indemnify the PMC/Client and its personnel and agents from and against all liability in respect thereof, and will be responsible for death or personal injury, loss of or damage to property, and any other loss, damage, costs, and expenses incurred as a result of the inspection.

1.6. Getting information from web portal

- 1.6.1. All prospective bidders are expected to see all information regarding submission of bid for the Work published in the e tender website during the period from the date of publication of NIT for the Work and up to the last date and time for submission of bid. Non observance of information published in the website shall not be entertained as a reason for any claim or dispute regarding a tender at any stage.
- 1.6.2. All bids shall be submitted online on the e-GP website only in the relevant envelope(s)/ cover(s), as per the type of tender. No manual submission of bids shall be entertained for the tenders published through e-GP system under any circumstances.

- 1.6.3. The e-GP system shall not allow submission of bids online after the stipulated date & time. The bidder is advised to submit the bids well before the stipulated date & time to avoid any kind of network issues, traffic congestion, etc. In this regard, the department shall not be responsible for any kind of such issues faced by bidder.

2. Bidding Documents

2.1. Content of Bidding Documents

- 2.1.1. The bidding documents shall consists of the following unless otherwise specified

- a. Notice Inviting Tender(NIT)
- b. Instructions to Bidders
- c. General and special Conditions of Contract
- d. Technical Specifications
- e. Form of Bid, Appendix to Bid, Preliminary agreement format
- f. Bill of Quantities
- g. Drawings

- 2.1.2. The Bidder is required to login to the e-procurement portal and download the listed documents from the website as mentioned in NIT. He shall save it in his system and undertake the necessary preparatory work off-line and upload the completed bid at his convenience before the closing date and time of submission.

- 2.1.3. The bidder is expected to examine carefully all instructions, Conditions of Contract, Contract Data, Forms, Terms, Technical Specifications, Bill of Quantities, Annexure and Drawings in the Bid Document. Failure to comply with the requirements of Bid Document shall be at the Bidder's own risk.

2.2. Clarification of Bidding Documents

- 2.2.1. A prospective bidder requiring any clarification of the bidding documents shall contact the office of the Tender Inviting Authority on any working day between 10 AM and 5 PM.

- 2.2.2. In case the clarification sought necessitates modification of the bid documents, being unavoidable, the Tender Inviting Authority may effect the required modification and publish them in the website through corrigendum in pursuance to clause 2.3 of this bid document.

2.3. Amendment to bidding documents

- 2.3.1. Before the deadline for submission of bids, the Tender Inviting Authority may modify the bidding document by issuing addenda.

- 2.3.2. Any addendum thus issued shall be a part of the bidding documents which will be published in the e-tender website. The Tender Inviting Authority will not be responsible for the prospective bidders not viewing the website in time.

- 2.3.3. If the addendum thus published does involves major changes in the scope of work, the Tender Inviting Authority may at his own discretion, extend the deadline for submission of bids for a suitable period to enable prospective bidders to take reasonable time for bid preparation taking into account the addendum published.

3. Preparation of Bids

3.1. Language of the Bid

3.1.1. All documents relating to the bid shall be in the English language.

3.2. Documents Comprising the Bid

3.2.1. The online bid submitted by the bidder shall comprise the following:

- i. Details required for e-payment (Details of bank account having core banking facility and e-mail address of the contractor) in the prescribed format.
- ii. Online payment of bid submission fee as detailed in the e-tender web site.
- iii. Bid Security payment details.
- iv. Copy of Registration Certificate duly attested.
- v. Copy of Documents in proof of eligibility criteria
- vi. Duly signed preliminary agreement.
- vii. Priced Bill of Quantities.

3.2.2. The relevant CPWD/MoRTH specifications and BIS/IS codes and the relevant sections of the National Building Code, CPWD Manual, CPWD Quality Control Manual and the CPWD Quality Control Laboratory Manual shall be considered as part of this bid documents though individual copies are not attached along with the bid documents.

3.2.3. Bidders shall not make any addition, deletion or correction in any of the bid documents. If tampering of documents is noticed during tender evaluation, the bid will be rejected and the bidder will be blacklisted.

3.3. Bid Prices

3.3.1. The Bidder shall bid for the whole work as described in the Bill of Quantities.

3.3.2. For item rate tenders, the bidder shall fill in rates in figures and should not leave any cell blank. The line item total in words and the total amount shall be calculated by the system and shall be visible to the Bidder.

3.3.3. The rates quoted by the Bidder shall include cost of all materials and conveyance, labour charges, hire charges of plant and machinery, overheads and all incidental charges for execution of the contract. The rate quoted shall also include all statutory taxes as on the date of submission of the tender and such taxes shall be paid by the contractor.

3.3.4. The quoted rates shall also include expenses towards all Quality Control tests (first tier) prescribed in the CPWD Quality Control Manual to be done at Government approved institutions.

3.3.5. GST or any other tax applicable shall be payable by the Contractor in respect of this contract and PMC/Client will not entertain any claim whatsoever in respect of the same.

3.3.6. All taxes, royalty, octroi and other levies payable by the contractor under the contract, or for any other cause as of the date 28 days prior to the deadline for submission of bids shall be included in the rates, prices and total of bid price. The bid prices shall also cater for any change in tax pattern during the tenure of work.

3.3.7. No material will be issued by the department for executing the building works under this contract.

3.3.8. The rates and prices quoted by the bidder shall remain firm during the entire period of contract. In the case of Works for which time of completion originally fixed exceeds 18 months, rates and prices quoted by the bidder are subject to price adjustment during the performance of the contract in accordance with the provisions of Clause 4.2 of the General Conditions of Contract.

3.4. Currencies of Bid and Payment

3.4.1. The currency of bid and payment shall be quoted by the bidder entirely in Indian Rupees. All payments shall be made in Indian Rupees only.

3.5. Bid Validity

3.5.1. Bids shall remain valid for the period of 180 (One Hundred and Eighty) days from the date of opening of the bid as specified in the NIT. A bid valid for a shorter period shall be rejected by the PMC as non responsive.

3.5.2. In exceptional circumstances, prior to expiry of the original bid validity period, the Tendering Authority may request the bidders to extend the period of validity for a specified additional period. The request and the responses thereto shall be made in writing or by e mail. A bidder may refuse the request without forfeiting its bid security. A bidder agreeing to the request will not be required or permitted to modify its bid, but will be required to extend the validity of its bid security for the period of the extension and in compliance with Clause 3.6 in all respects.

3.6. Bid Security

3.6.1. The Bidder shall furnish, as part of his Bid, a Bid Security for an amount as detailed in the Notice Inviting Tender (NIT). For e-tenders, Bidders shall remit the Bid Security using the online payment options of e-Procurement system only.

Bidders are advised to visit the "Downloads" section of e-Procurement website www.etenders.kerala.gov.in for State Bank of India or by using NEFT facility. Bidders opting for NEFT facility of online payment are advised to exercise this option at least 24 hours before the last date of bid submission to ensure that payment towards Bid Security is credited and a confirmation is reflected in the e-Procurement system. The online NEFT remittance form provided by e-Procurement system for making a NEFT transaction is not a payment confirmation. PMC/NIC/SBI/KSITM/Client shall not be responsible for any kind of delay in payment status confirmation.

3.6.2. Any Bid not accompanied by an acceptable Bid Security shall be rejected by the PMC as non-responsive.

3.6.3. The Bid Security of the unsuccessful Bidder shall become refundable as promptly as possible after opening of Price Bid and finalization of the tender.

3.6.4. The Bid Security of the successful Bidder will be discharged when the Bidder has furnished the required Performance Guarantee and signed the Agreement.

3.6.5. Waiving of Bid Security is allowed in respect of organizations, which are exempted by Government to that effect. In this case, the bidder shall produce

copy of Government order showing exception in remittance of bid security while participating in the tender process.

SSI/MSME units interested in availing exemption from payment of Bid Security should submit a valid copy of their registration certificate issued by the concerned DIC or NSIC/Udyog Aadhaar. But the Party has to provide Performance Security if Tender is awarded to them.

Note: If the bidder is a MSME, it shall declare in the bid document the Udyog Aadhar Memorandum Number issued to it under the MSMED Act, 2006. If a MSME bidder do not furnish the UAM Number along with bid documents, such MSME unit will not be eligible for the benefits available under Public Procurement Policy for MSEs Order 2012.

3.6.6. The Bid Security may be forfeited:

- 1) if the Bidder withdraws the Bid after Bid opening during the period of Bid validity including extended period of validity; or
- 2) if any modification is effected to the tender documents or
- 3) in the case of a successful Bidder, if the Bidder fails within the specified time limit to:
 - a) sign the Agreement; or
 - b) Furnish the required Performance Guarantee or
 - c) If the bidder fails to convince the PMC about the reasonability of his bid prices in the case of an unbalanced bid.
- 4) In such cases the work shall be rearranged at the risk and cost of the selected bidder.

3.6.7. The Bid Security deposited with the PMC will not carry any interest.

3.7. Bid submission fee

3.7.1. For e-tenders, the mode of remittance of Bid submission fee (Tender Fee) shall be the same as detailed for remitting Bid Security. For e-tenders, Bidders shall remit the Tender fee using the online payment options of e-Procurement system only. Bidders are advised to visit the "Downloads" section of e-Procurement website www.etenders.kerala.gov.in for State Bank of India or by using NEFT facility. Bidders opting for NEFT facility of online payment are advised to exercise this option at least 24 hours before the last date of bid submission to ensure that payment towards Bid Submission Fee is credited and a confirmation is reflected in the e-Procurement system. The online NEFT remittance form provided by e-Procurement system for making a NEFT transaction is not a payment confirmation. PMC/NIC/SBT/KSITM/Client department shall not be responsible for any kind of delay in payment status confirmation.

3.7.2. Any bid not accompanied by the Tender Fee as notified shall be rejected by the PMC as nonresponsive.

3.7.3. Tender Fee remitted will not be refunded.

3.8. Alterations and additions

3.8.1. The bid shall contain no alterations or additions, except those to comply with instructions issued by PMC, or as necessary to correct errors made by the bidder, in which case such corrections shall be initialed by the person or persons signing the bid.

3.8.2. The bidder shall not attach any conditions of his own to the Bid. The Bid price must be based on the tender documents. The bidder is not required to present alternative construction options and he shall use without exception the Bills of Quantities as provided, with the amendments as notified in tender notices, if any, for the calculation of his tender price. Any bidder who fails to comply with this clause will be disqualified.

4. Submission of Bids

- 4.1. All documents of the Bid as required shall be typed or written in indelible ink and shall be signed by the bidder or person duly authorised to sign on behalf of the Bidder.
- 4.2. In the event of the tender being submitted by a partnership firm, it must be signed by the lead partner holding a valid power-of attorney authorizing him to do so, such power of attorney to be produced with the tender, and it must disclose that the firm is duly registered under the Indian Partnership Act, 1952.
- 4.3. The Bidder shall submit their bid online only through the e-GP web site of Kerala (www.etenders.kerela.gov.in) as per the procedure laid down for e-submission as detailed in the web site. For e tenders, the bidders shall download the tender documents including the Bill of Quantity (BoQ) file from the e tendering portal <http://www.etenders.kerala.gov.in>. The Bidder shall fill up the documents and submit the same online using their Digital Signature Certificate. On successful submission of bids, a system generated receipt can be downloaded by the bidder for future reference. Copies of all certificates and documents shall be uploaded while submitting the tender online. The following scanned copies of documents are to be submitted online as required by the e-tenders portal.
 - 4.3.1. Copy of remittance towards bid submission fee and Bid Security.
 - 4.3.2. Self-attested Copy of GST registration certificate and experience certificate as per clause 1.3.1.a and 1.3.1.b of ITB
 - 4.3.3. Duly filled and signed copy of bid submission letter as per item no-1 Part-VI of this bid document.
 - 4.3.4. Duly filled and signed copy of preliminary agreement as per item no-2 Part-VI of this bid document.
 - 4.3.5. Duly filled and signed copy of Integrity pact certificate as per item no-3 Part-VI of this bid document.
 - 4.3.6. Duly filled and signed copy of Affidavit as per item no-4 Part-VI of this bid document.
 - 4.3.7. Duly filled and signed copy of requisition for e-payment form as per item no-5 Part-VI of this bid document.
 - 4.3.8. Any other relevant information with testimonials.
 - 4.3.9. The bidder shall digitally sign all statements, documents, certificates uploaded by him, owning sole and complete responsibility for their correctness/authenticity as per the provisions of the IT ACT 2000.

- 4.3.10. In addition to the above, the bidder shall upload a complete set of bid document with NIT and sections from 1 to VII using his digital signature as a token of acceptance of all bid conditions and the absence of complete set of bid document in the submitted bid shall be treated as non-responsive and will be rejected by the PMC.
- 4.3.11. Price bid
- 4.3.11.1. This shall contain only the duly filled BoQ-file in MS-Excel format and shall be uploaded using the digital signature of the bidder in the e-tenders portal.
- 4.4. After the submission of bid online in the e-tenders portal, the hard copies of the following are to be submitted to the Tender Inviting Authority on written demand by the tender inviting authority.
- 4.4.1.1. Copy of remittance towards bid submission fee and Bid Security.
- 4.4.1.2. Copy of confirmation of bid submission in the e-tenders portal.
- 4.4.1.3. Self attested Copy of the bidder's valid registration certificate in Kerala PWD, CPWD or other approved agencies as per clause 1.3.1.
- 4.4.1.4. Duly filled and signed copy of bid submission letter as per item no-1 Part-VI of this bid document in original.
- 4.4.1.5. Duly filled and signed copy of preliminary agreement as per item no-2 Part-VI of this bid document in original.
- 4.4.1.6. Duly filled and signed copy of Integrity pact certificate as per item no-3 Part-VI of this bid document in original.
- 4.4.1.7. Duly filled and signed copy of Affidavit as per item no-4 Part-VI of this bid document in original.
- 4.4.1.8. Duly filled and signed copy of requisition for e-payment form as per item no-5 Part-VI of this bid document in original.
- 4.5. On demand of the Tender Inviting Authority, this whole set of certificates and documents shall be send to the Tender Inviting Authority's office address (as given in the NIT) by registered post/Speed post of India Post in such a way that it shall be delivered to the Tender Inviting Authority before the deadline mentioned. The Tender Inviting Authority reserves the right to reject any bid, for which the above details are not received before the deadline.
- 4.6. The bid shall only be submitted through online. The Tender Inviting Authority shall open the price bid in the presence of bidders or their authorised representatives preferably on the last day of bid submission after the prescribed time for bid submission.
- 4.7. The Tender Inviting Authority shall not be responsible for any failure, malfunction or breakdown of the electronic system while downloading or uploading the documents by the Bidder during the e-procurement process.
- 4.8. Deadline for Submission of the Bids
- 4.8.1. Bid shall be received only online on or before the date and time as notified in NIT.

4.8.2. The Tender Inviting Authority, in exceptional circumstances and at its own discretion, may extend the last date for submission of bids, in which case all rights and obligations of the PMC and the bidders previously subject to the original date will then be subject to the new date of submission.

4.8.3. The Bidder will not be able to submit his bid after expiry of the date and time of submission of bid (server time).

4.9. Modification, Resubmission and Withdrawal of Bids

4.9.1. Resubmission or modification of bid by the bidders for any number of times before the date and time of submission is allowed. Resubmission of bid shall require uploading of all documents including price bid afresh.

4.9.2. If the bidder fails to submit his modified bids within the pre-defined time of receipt, the system shall consider only the last bid submitted.

4.9.3. The Bidder can withdraw his/her bid before the date and time of receipt of the bid. The system shall not allow any withdrawal after the date and time of submission.

5. Bid Opening and Evaluation

5.1. Bid Opening

5.1.1. Bids shall be opened on the specified date & time, by the tender inviting authority or his authorised representative in the presence of bidders or their designated representatives who choose to attend.

5.1.2. Opening of bids shall be carried out in the same order as it is occurring in invitation of bids or as in order of receipt of bids in the portal. The bidders & guest users can view the summary of opening of bids from any system. Bidders are not required to be present during the bid opening at the opening location if they so desire.

5.1.3. In the event of the specified date of bid opening being declared a holiday for the PMC, the bids will be opened at the same time on the next working day.

5.2. Confidentiality

5.2.1. Information relating to the examination, clarification, evaluation, and comparison of Bids and recommendations for the award of a contract shall not be disclosed to Bidders or any other persons not officially concerned with such process until the award has been announced in favour of the successful bidder.

5.2.2. Any effort by a Bidder to influence the PMC during processing of bids, evaluation, bid comparison or award decisions shall be treated as Corrupt & Fraudulent Practices, mentioned under Clause 9 of ITB and may result in the rejection of the Bidders' bid.

5.3. Clarification of Bids

5.3.1. To assist in the examination, evaluation, and comparison of bids, the Tender Inviting Authority may ask the bidder for required clarification on the information submitted with the bid. The request for clarification and the response shall be in

writing or by e-mail, but no change in the price or substance of the Bid shall be sought, offered, or permitted.

- 5.3.2. Subject to clause 5.3.1, no Bidder shall contact the Tender Inviting Authority on any matter relating to the submitted bid from the time of the bid opening to the time the contract is awarded. If the Bidder wishes to bring additional information to the notice of the Tender Inviting Authority, he shall do so in writing.

5.4. Examination of Bids, and Determination of Responsiveness

- 5.4.1. During the bid opening, the Tender Inviting Authority will determine for each Bid whether it meets the required eligibility as specified in the NIT; is accompanied by the required bid security, bid submission fee and the required documents and certificates.

- 5.4.2. A substantially responsive bid is one which conforms to all the terms, conditions, and requirements of the bidding documents, without material deviation or reservation. A material deviation or reservation is one

- a. which affects in any substantial way the scope, quality, or performance of the Works;
- b. which limits in any substantial way, inconsistent with the bidding documents, the PMC's rights or the Bidder's obligations under the Contract; or
- c. whose rectification would affect unfairly the competitive position of other Bidders presenting substantially responsive Bids.

- 5.4.3. If a Bid is not substantially responsive, it may be rejected by the Tender Inviting Authority, and may not subsequently be made responsive by correction or withdrawal of the nonconforming material deviation or reservation.

- 5.4.4. Non submission of legible or required documents or evidences may render the bid non-responsive.

- 5.4.5. Bidder can witness the principal activities and view the documents/summary reports for that particular work by logging on to the portal with his DSC from anywhere.

- 5.4.6. Single tender shall not be opened in the first tender call.

5.5. Negotiation on Bids

- 5.5.1. The Tender Inviting Authority reserves the right to negotiate with the lowest evaluated responsive bidder.

6. Award of Contract

- 6.1. Subject to Clause 5, the Agreement Authority will award the Contract to the Bidder whose bid has been determined to be substantially responsive and who has offered the lowest evaluated bid price.

- 6.2. In the eventuality of failure on the part of the lowest successful bidder to produce the original documents, or submit the performance security, or enter into agreement with the Agreement Authority within the specified time limit, subjected to clause 3.6.6 of this section, the Bidder shall be debarred in future from participating in Bids for three years

and will be recommended for blacklisting by the competent authority. In such cases, the work shall be re-tendered.

- 6.3. If the grand total quoted amount by a bidder is less than 75% (seventy-five percent) of the total estimated cost put to tender, then such bids will be processed based on the directions contained in Government order GO (P) No-124/2016/Fin dated 29-8-2016 or any subsequent modifications thereof. If two or more bidders quote the same lowest amount, the Tender Inviting Authority shall finalize the tender through a transparent draw of lots. The Tender Inviting Authority along with his subordinate officers and the contractors who have quoted the lowest and equal amounts in their bids (or contractor's authorised representatives) shall be present during the draw of lots.
- 6.4. The rates for the various items quoted by the Bidder shall be rounded to two decimal places. The decimal places in excess of two will be discarded during evaluation.
- 6.5. Project Management Consultant (PMC)'s Right to accept any Bid and to reject any or all Bids
 - 6.5.1. Notwithstanding Clause 6.1 to 6.4, the Tender Inviting Authority reserves the right to accept or reject any Bid and to cancel the Bidding process and reject all Bids at any time prior to the award of Contract, without thereby incurring any liability to the affected Bidder or Bidders or any obligation to inform the affected Bidder or Bidders of the grounds for the Tender Inviting Authority's action.

6.6 Notification of Award and Signing of Agreement

- 6.6.1. The Bidder, whose Bid has been accepted, shall be notified of award by the Agreement Authority prior to expiration of the Bid validity period by facsimile or e-mail confirmed by letter sent through post. This letter (hereinafter and in the Conditions of Contract called the "Letter of Acceptance") will state the sum that the Project Management Consultant (PMC)/Client Department will pay the Bidder in consideration of the execution, completion and remedying defects, if any of the Works by the Contractor as prescribed by the Contract.
- 6.6.2. The notification of award will constitute the formation of the Contract, subject only to the furnishing of a Performance Guarantee in accordance with the provisions of Clause 7, within 14(fourteen) days of issue of letter of acceptance.
- 6.6.3. If the successful bidder fails to furnish the required Performance Guarantee as detailed in clause 7 of this section and enter into contract, within the above stipulated time, further ten days time will be allowed at the request of the bidder, for which the successful bidder has to remit a fine equal to 1% of the Contract Price as per his quote amount subject to a minimum of Rs.1000 and maximum of Rs.25,000. This fine shall be remitted in the form of demand draft drawn from a nationalized bank in favor of HLL Lifecare Limited payable at Thiruvananthapuram.
- 6.6.4. Upon the furnishing by the successful Bidder of the Performance Guarantee, the Agreement Authority will promptly notify the other Bidders that their Bids have been unsuccessful and refund the Bid Security.
- 6.6.5. Solicitor's fee, if any, to be paid to the Law Officers of Government for scrutinizing or drawing up of agreements - will be paid and the same recovered from the successful bidder.

7. Performance Guarantee and Performance Security Deposit

- 7.1 The bidder whose tender is accepted shall be required to furnish the following
- 7.1.1. Performance Guarantee to be submitted before executing agreement and
 - 7.1.2. Performance Security Deposit to be recovered from running bills.
- 7.2. Performance Guarantee to be submitted at the award of contract should be 5% of Contract amount and should be submitted within 14 (fourteen) days of receipt of LOA (Letter of Acceptance) by the successful Bidder in the following form
- 7.2.1. Performance Guarantee shall be submitted in the form of demand draft drawn from a nationalized bank in favor of HLL Lifecare Limited payable at Thiruvananthapuram and shall be valid till 28(twenty-eight) days after the completion of defect liability of the Work.
- 7.3. After the submission of Performance Guarantee and its acceptance, the Bid Security will be refunded to the successful bidder.
- 7.4. Performance Security Deposit shall be deducted at 2.5% from running bills. Total of Performance Guarantee is 5% of contract amount while total of Performance Security Deposit is 2.5% of the value of work done.
- 7.5. Deleted
- 7.6. The Performance Guarantee amounts shall be payable to the Project Management Consultant (PMC) without any condition whatsoever.
- 7.7. The Performance Guarantee shall cover additionally the following guarantees to the PMC:
- 7.7.1. The successful bidder guarantees the successful and satisfactory completion of the infrastructure and other related works under the contract, as per the specifications and documents.
 - 7.7.2. The successful bidder further guarantees that the infrastructure and equipments provided and installed by him shall be free from all defects in material and workmanship and shall, upon written notice from the Agreement Authority or the Engineer-in-charge, fully remedy free of expenses to the PMC/Client, such defects as developed under the normal use of the said infrastructure within the period of defect liability specified under clause 46 of the Conditions of Contract.
- 7.8. The Performance Guarantee is intended to secure the performance of the entire Contract. However, it is not construed as limiting the damages stipulated in the other clauses in the bidding documents.
- 7.9. The Agreement Authority shall be at liberty to deduct/appropriate from the Contract Performance Guarantee/Performance Security Deposit such sums as are due and payable by the contractor to the Client/PMC as may be determined in terms of the contract, and the amount appropriated from the Performance Guarantee/Performance Security Deposit shall have to be restored by Contractor subsequently.

- 7.10. The Performance Guarantee submitted will be returned to the Contractor without any interest after 28 days after the satisfactory completion of defect liability period.
- 7.11. Performance Security Deposit shall bear no interest and this amount will be released after passing the final bill as in the case of refund of deposit.
- 7.12. Failure of the successful Bidder to comply with the requirements of sub-clause 7.2 shall constitute sufficient grounds for cancellation of the award and forfeiture of the Bid Security.

8. First tier Quality Control Tests

- 8.1. Primary responsibility of maintaining quality of all items of work as per specifications and standards prescribed in the CPWD Quality Control Manual vests with the Contractor. The Contractor shall carry out all First tier Quality Control tests prescribed by the PWD Quality Control Manual at his own expense and submit it along with the bills submitted for payment. If the estimated cost exceeds Rs. 2 Crores, the Contractor shall establish field laboratory at the site at his own expense.

9. Corrupt or Fraudulent Practices

- 9.1. It is required that the bidders observe the highest standard of ethics during the procurement and execution of such contracts. In pursuance of this policy, it is defined, for the purposes of this provision, the terms set forth below as follows:
- 9.1.1. "Corrupt practice" means the offering, giving, receiving or soliciting of anything of value to influence the action of a public official in the procurement process or in contract execution; and
- 9.1.2. "Fraudulent practice" means a misrepresentation of facts in order to influence a procurement process or the execution of a contract to the detriment of the PMC/Client Department and includes collusive practice among Bidders (prior to or after bid submission) designed to establish bid prices at artificial noncompetitive levels and to deprive the Government of the benefits of free and open competition.
- 9.1.3. "Collusive practice" is an arrangement between two or more parties designed to achieve an improper purpose, including to influence improperly the actions of another party;
- 9.1.4. "Coercive practice" is impairing or harming, or threatening to impair or harm, directly or indirectly, any party or the property of the party to influence improperly the actions of a party.
- 9.2. The PMC will reject a bid, and/or award if it determines that the Bidder recommended for award has engaged in any of the corrupt or practices in competing for the contract in question and will declare the firm ineligible, either indefinitely or for a stated period of time, to be awarded a contract, if it at any time determines that the firm has engaged in corrupt or fraudulent practices in competing for, or in executing the contract.

10. Forms and declarations

- 10.1. Various forms and formats for declarations to be submitted by the Bidder for Bid submission are included in the Part-VI- FORMS. Bidders are requested to fill in the required forms and declarations and submit the same with their bids both online and in hard copy on demand of tender inviting authority.

Part II

GENERAL CONDITIONS OF CONTRACT

1. Definitions

- 1.1. "Employer" shall mean Project Management Consultant (PMC) i.e. HLL Lifecare Limited (HLL), Thiruvananthapuram or its units thereof, on whose behalf the Work is taken up for execution.
- 1.2. Accepting Authority/Agreement Authority means the officer who has invited and received bids for the Work and has executed agreement for execution on behalf of the PMC.
- 1.3. "Client" or "Department" shall mean The District Collector, Thiruvananthapuram or his/her legal assigns.
- 1.4. "Engineer-In-Charge", shall mean the Engineer appointed by the Project Management Consultant to supervise all activities of the project.
- 1.5. "Contractor", shall mean the successful bidder whose tender has been accepted by the Project Management Consultant and to whom the order is placed by the Project Management Consultant and shall include his heirs, legal representatives, successors etc.
- 1.6. Contract is the agreement between the Agreement Authority and the selected Bidder to execute, complete and maintain the Work.
- 1.7. Contract Price is the price stated in the Letter of Acceptance and thereafter as adjusted in accordance with the provision of the contract.
- 1.8. Contract Data defines the documents and other information which comprise the contract.
- 1.9. Bid or Tender means the Contractor's priced offer to the PMC for the execution and completion of the Work and the remedying of any defects therein in accordance with the provisions of Contract.
- 1.10. Bill of Quantities means the priced and completed Bill of Quantities forming part of the bid.
- 1.11. Specification means the instructions, provisions, conditions and detailed requirements contained in the tender documents which form part of the contract and any modification or addition made or approved by the Accepting Authority.
- 1.12. Drawings means all drawings, calculations and technical information related to the Work provided by the Engineer from time to time to the Contractor under the Contract.
- 1.13. Letter of Acceptance or selection notice means intimation issued by the Accepting Authority as formal acceptance of Bid by the PMC.
- 1.14. Date of commencement means the date of handing over the site to the Contractor.

- 1.15. Time of completion means the period allowed for completing all works related to the Work including carrying out and passing the required quality control tests prescribed by the Quality Manual published by the Department.
- 1.16. Date of completion shall be the date of issue of virtual completion certificate. The virtual completion certificate shall be issued by the Engineer-in charge within 15 days of the final measurement and shall specify the work has been completed satisfactorily by the contractor and taken over by the Department. In case of defects liability period the works shall be finally taken over after completion of defects liability period.
- 1.17. Quality control tests means all relevant tests prescribed by the CPWD Quality Control Manual applicable to the Work which are to be made and passed before each part bill is presented for payment.
- 1.18. A Defect is any part of the work not completed in accordance with the contract.
- 1.19. Defects Liability Period is the period named in the contract data and calculated from the date of completion.
- 1.20. Plant is any integral part of the works which is to have a mechanical, electrical, electronic or biological function.
- 1.21. Equipment means contractor's machinery and vehicles brought temporarily to site for execution of the Work.
- 1.22. Site means the places provided by the PMC/Client where the Work is to be executed. It may also include any other place or places as forming part of the site, mentioned in the Contract.
- 1.23. Materials means all supplies, including consumables used by the contractor for incorporation in the works
- 1.24. Works are what the Contract requires the contractor to construct, install and run over to the PMC/Client as defined in Contract Data.
- 1.25. Days are calendar days, months calendar months.
- 1.26. "Codes" shall mean the following, including the latest amendments, and/or replacements, if any:
- a. Bureau of Indian Standards/Indian Roads Congress relevant to the works under the Contract and their specifications. If Indian Standards are not available British Standards or AASHTO Standards are to be followed.
 - b. Other Internationally approved Standards and/or rules and regulations touching the subject matter of the Contract.
 - c. Any other laws, rules, regulations and Acts applicable in India with respect to labour, safety, compensation, insurance etc.
- 1.27. Words importing singular only shall also include the plural and vice-versa where the context so requires.

- 1.28. Words importing "Person" shall include firms, companies, corporations, and associations or bodies of individuals, whether incorporated or not.
- 1.29. Terms and expressions, not defined herein, shall have the same meaning as are assigned to them in the Indian Contract Act, and failing that in the General Clauses Act.
- 1.30. "Government Approvals" shall mean all permits, licenses, authorisations, consents, clearances, decrees, waivers, privileges, approvals from and filing with government instrumentalities necessary for the development, construction and operation of the Work.
- 1.31. Measurement Books: The "measurement books" shall be defined as Computerized Measurement Book having pages of A-4 size as per the format of the PMC so that a complete record is obtained of all the items of works performed under the contract. It should be submitted by the contractor to the PMC after verification and certification by the Engineer-in-Charge or his authorized representative, duly bound, with its pages machine numbered, should be 100% correct, and no cutting or over-writing in the measurements would thereafter be allowed. All measurement books shall be certified by the Engineer-in-Charge before entering measurements.

2. Scope, extent, intent etc

- 2.1 Scope: The general character and the scope of the Work shall be as illustrated and defined in the Drawings, Specifications, Schedule of Rates and other Contract Documents.
- 2.2 Extent: The Contractor shall carry out and complete the Work under the Contract in every respect, and his work shall include the supply of all labour, equipment, materials, plant and machinery, tools, transportation, form work, scaffolding and everything else necessary for the proper execution and completion of the Work in accordance with the Contract Documents and to the satisfaction of the Engineer-in charge. The Contractor shall be fully responsible and liable for everything and all matters in connection with or arising out of or being a result or consequence of his carrying out or omitting to carry out any part of the Work. Where any parts of the Work may be executed by Sub-Contractors, such responsibility and liability of the Contractor shall cover and extend to the work of all such Sub-Contractors.
- 2.3 Intent: The Contract Documents are complementary and what is called for by any one shall be binding as if called for by all. Wherever it is mentioned in the Contract Documents that the Contractor shall perform certain work or provide certain facilities, it is understood that the Contractor shall do so at his own cost. Materials or work described in words which so applied have a well-known technical or trade meaning shall be held to refer to such recognized standards as are applicable.

3. SITE

- 3.1. Contractor to satisfy himself about site conditions: The Contractor ensures that before submitting bids for the Work the Contractor has visited the Site and satisfied himself about the Site conditions for construction and for logistics and smooth flow of workmen and materials as well as permission from Authorities for this purpose. The Contractor has examined the Site and taken note of character of the soil and of the excavations, the correct dimensions of the Work, and facilities for obtaining any special articles called for in the Contract Documents. The Contractor has also made its own assessment and

obtained all information on the Site constraints and on all matters that will affect the execution, continuation and progress, and completion of the Works. Any extra claims or extension of time made in consequence of any misunderstanding, incorrect information on any of these points or on the grounds of insufficient description or information shall not be entertained or allowed at any stage.

- 3.2 It will be the responsibility of the contractor to obtain necessary land for stacking the materials and establishing plants and equipments for carrying out the work, if the specified site of work is of less extents.
- 3.3. Land required for the work may not be available in full. Further land will be handed over as and when it is received from the Land Acquisition Authority. The contractor shall not be eligible for any extra or enhance claims or for compensation due to the non-availability of entire land. He shall also not be eligible for any claims or compensative for the non-completion of the work within the agreed time and for continuing the work in the agreed extended period of completion due to the above reasons.
- 3.4. In the case of any delay in shifting the utility services like Telephone posts, Electric posts, Electric over head line and underground cables, water lines etc. by the utility Department, the PMC/Client Department shall not in any way be liable to pay damages on account of this delay, instead a proportionate extension of time for completion of work will be granted in deserving cases on application by the Contractor.
- 3.5. Access to site by the contractor: The access to the Site will be shown immediately on award of the Contract to the Contractor and the Site shall be shared with other Contractors and Sub-Contractors as applicable. The Contractor shall upon being given such access commence the Work and diligently proceed with the execution of the Work in accordance with the Contract Documents. Access to the Site by the Contractor shall be merely a licence for carrying out the construction of the Work under the Contract, and the Contractor shall not by his being allowed such entry on the Site, acquire any right, lien or interest either in the Work carried out by him under the Contract or anything appurtenant or attached thereto or to any part of the Site, and his claim will only be in the nature of money found due and payable to him in accordance with the certificates issued by the Engineer-in-charge under the provisions contained herein. The Work shall be free from all liens, charges or claims of whatsoever nature from any party other than the Engineer. The Engineer shall have a lien over all work performed by the Contractor, Sub-Contractors and Vendors and also for the materials and equipment brought on Site by them.
- 3.6. The Department does not undertake to construct or make available any approach road or other means of approach to the proposed work site and the contractor shall get acquainted with the available means of approaches to the proposed site and quote for the various items. The Department shall not be liable for any claim raised later on the plea of non-availability or non-access to the site
- 3.7. Treasures, Antiquities found are property of Client/Department: All fossils, antiquities and other objects of interest or value, which may be found on the Site at the commencement or during the progress of the Work, shall be the property of the Client or Department. The Contractor shall carefully take out and preserve all such fossils, antiquities and objects and shall immediately deliver the same in their discovered state into the possession of the PMC/Client or Department.

4. Nature of contract

- 4.1. The Contract shall be an item rate Contract wherein the item rates are for the finished work as per the Contract Documents. The estimated cost is tentative based on the estimated quantities and is liable to change during execution as per the actual quantities executed and approved by the Engineer-in charge. The Contractor understands and agrees that the amount payable is assessed on a re-measurable basis in accordance with the BOQ rates. The Contract Price shall include payment for the supply of all labour (including payment to his Sub-Contractors), equipment, materials, plant and machinery, tools, transportation, formwork, scaffolding, works under this contract and all applicable taxes including the GST, Work Contract Tax (WCT), Value added tax(VAT), duties, octroi, levies, royalties, fees, insurance premiums, contributions towards employees benefits including Employee State Insurance and Provident Funds, arrangement of power and water and all services and activities constituting the Scope of Work defined in the General Conditions of Contract. The Contract Price shall also include expenses for the Contractor's site establishment, infrastructure, overheads & profits, establishing site laboratories (for works costing more than Rs. 2 Crores), first tier quality control tests, expenses for all rectifications including that necessitated as a result of bad quality and all other charges required by the Contract to be borne by the Contractor and necessary for the proper execution and completion of the Work under the Contract, in conformity with the Contract Documents and according to the best engineering and construction practices and to the satisfaction of the Engineer-in-charge.
- 4.2. No adjustment of the prices shall be allowed during the period of the contract for works which have a period of completion up to 18 (eighteen) months for any reasons whatsoever and the prices quoted by the Contractor shall be deemed to be fixed for the entire contract period. For works which have a original period of completion upto 18 (eighteen) months, and if the time of completion is extended beyond 18 (eighteen) months in accordance with clause 19 of GCC, there shall not be any escalation in the price. For works which have a time of completion more than 18 (eighteen) months, price adjustment will be permitted subjected to the provisions in clause 40 of GCC.

5. Notices, Fees, Byelaws, Regulations, etc

- 5.1. The Contractor shall comply with all applicable laws and Government Acts including the Byelaws or regulations of Central and / or Local Authorities relating to the Work in so far as labour, construction, fabrication and installation activities are concerned, and he shall obtain from the Central and / or Local Authorities all permissions and approvals required for the plying of trucks, construction machinery etc., and also for construction of temporary offices, labour camps, batching plant, hot mix plant, base camp, stores and other temporary structures in connection with the Work, and the Contractor shall give all notices and pay all fees and charges that are and that can be demanded by law there under. In the Contract Price for the Work, the Contractor shall allow for such compliance and work, and for the giving of all such notices, and shall include the payment of all such fees and charges.
- 5.2. The contractor is bound to follow relevant Government orders, circulars, CPWD Manuals etc prevailing at the time of contract connected to the execution of the work under the contract even though specific reference to these are not provided elsewhere in the contract conditions.

6. Licenses and permits

- 6.1. The Contractor shall directly obtain all licences and permits for the materials under Government control, and those required to be obtained by the Contractor for the execution of the Work. The Contract Price shall include all transportation charges and the other expenses that may be incurred in this connection.

7. Contract documents

- 7.1. The following documents shall constitute the Contract documents:

- a. Articles of Agreement
 - b. Notice Inviting Tender
 - c. Letter of Acceptance of Tender indicating deviations, if any, from the conditions of Contract incorporated in the Tender document issued to the bidder and/or the Bid submitted by the bidder,
 - d. Conditions of Contract, including general terms and conditions, instructions to bidders, additional terms and conditions, technical terms and conditions, erection terms and conditions, special conditions, if any etc. forming part of the Agreement
 - e. Specifications, where it is part of Tender Documents
 - f. Scope of works/Bills of quantities/schedule of works/quantities and
 - g. Contract Drawings and finalised work programme.
- 7.2. After acceptance of Tender the Contractor shall be deemed to have carefully examined all Contract Documents to his satisfaction. If he shall have any doubt as to the meaning of any portion of the Contract Documents, he shall before signing the Contract, set forth the particulars thereof, and submit them to the Agreement Authority in writing in order that such doubt may be removed. The Agreement Authority will provide such clarifications as may be necessary in writing to the Contractor. Any information otherwise obtained from the PMC or the Engineer shall not in any way relieve the Contractor of his responsibility to fulfill his obligations under the Contract.
- 7.3. The Contractor shall enter into a Contract Agreement with the Agreement Authority within 14 (fourteen) working days from the date of 'Acceptance of Tender' or within such extended time as may be granted by the Agreement Authority. The date of despatch of Letter of Acceptance by registered post shall be the date of Acceptance of Tender. The performance Guarantee for the proper fulfillment of the Contract shall be furnished by the contractor in the prescribed form within fourteen (14) days of 'Acceptance of Tender'. The performance Guarantee shall be as per terms prescribed in the clause 7 of "Instructions to Bidders" of this Tender.
- 7.4. The agreement, unless otherwise agreed to, shall be signed within 14(fourteen) working days from the date of Acceptance of Tender, at the office of the Agreement Authority on a date and time to be mutually agreed. The Contractor shall provide required details for signing of the contract like, performance guarantee in copies as required, appropriate power of attorney and other requisite materials. In case it is agreed mutually that the contract is to be signed beyond the stipulated time as specified in clause 6.6.3 of section Instructions to Bidders, the Bid Security or EMD submitted with the tender will have to be extended accordingly.

7.5. After the signing of the agreement with the Agreement Authority and the Contractor, two certified copies of the agreement are to be made. Original shall be kept with the Agreement authority and the Contractor shall be provided with one certified copy and the other certified copy shall be kept with the Engineer-in Charge. None of these documents shall be used for any purpose other than this Contract and the Contractor shall ensure that all persons employed for this Contract strictly adhere to this.

7.6. The laws applicable to this Contract shall be the laws in force in India.

8. Assignment and subletting of contract

8.1. The Contractor shall not assign this Contract. The Contractor shall not sub-let the Contract or any part thereof other than for supply of raw materials, for minor works or any special type of works for which makes are identified in the Contract or as approved by the Engineer-in charge. Suppliers of the equipment not identified in the Contract or any change in the identified supplier shall be subject to approval by the Engineer. The experience list of such equipment vendors under consideration by the Contractor for this Contract shall be furnished to the Engineer for approval prior to procurement of all such items/equipments. Such assignment /sub-letting shall not relieve the Contractor from any obligation, duty or responsibility under the Contract. Any assignment as above without prior written approval of Engineer-in Charge shall be void.

9. Patent rights and royalties

9.1. Royalties and fees for patent covering materials, articles, apparatus, devices, equipment or processes used in the works shall be deemed to have been included in the Contract Price. The Contractor shall satisfy all demands that may be made at any time for such royalties or fees and he alone shall be liable for any damages or claims for patent infringements and shall keep the PMC/Client Department indemnified in that regard. The Contractor shall, at his own cost and expense, defend all suits or proceedings that may be instituted for alleged infringement of any patent involved in the works, and, in case of an award of damages, the Contractor shall pay for such award. In the event of any suit or other proceedings instituted against the PMC/Client Department, the same shall be defended at the cost and expense of the Contractor who shall also satisfy/comply any decree, order or award made against the PMC/Client Department. But it shall be understood that no such machine, plant, work, material or thing for any purpose or any manner other than that for which they have been furnished and installed by the Contractor and specified under these specifications. Final payment to the Contractor by the PMC/Client Department will not be made while any such suit or claim remains unsettled. In the event any apparatus or equipment, or any matter thereof furnished by the Contractor, is in such suit or proceedings held to constitute infringement, and its use is enjoined, the Contractor shall, at his option and at his own expense, either procure for the PMC/Client department, the right to continue use of said apparatus, equipment or part thereof, replace it with non-infringing apparatus or equipment or modify it, so it becomes non-infringing.

10. Variation in quantity

10.1. The PMC/Client department/Engineer-in charge reserves the right to vary the quantities of items or groups of items to be ordered as specified in the Bill of quantities, as may be necessary, during the execution of the Contract. The Contractor is bound to execute such varied quantities of work at his quoted price up to an extent of 25% in excess of the agreed quantity or quantities. In case of variation over 25% in excess of the agreed

quantity, the department reserves the right to arrange such works through a separate contract. Negotiation shall be made with original contractor to revise the rate for the additional quantity in excess of 25% of the agreed quantity and in no case the revised rate shall be more than the market rate at the time of initiating the proposal for revision of rate as recommended by the Engineer-in charge. No increase shall be permitted within the original contract period and the rate in excess of market rate shall not be given under any circumstances. Upon rate revision shall be considered only in exceptional cases which shall be approved by the PMC for the enhanced rates based on the recommendation of the Engineer.

- 10.2. The Contractor is bound to carry out sinking of wells increase up to 10 meter (ten meter) extra depth beyond the estimated design depth and rate for which shall be paid as per schedule of rate and extra item conditions in case such items are included in the contract. In case of pile foundation, precast or cast in site, the same conditions as above shall apply.

11. Deductions from contract price

- 11.1. All costs, damages or expenses, which the PMC/Client may have paid, for which under the Contract the Contractor is liable, will be claimed by the PMC/Client. The Engineer-in charge shall deduct the amount, from any moneys due or becoming due by him to the Contractor under the Contract or may be recovered by actions of law or otherwise, if the Contractor fails to satisfy the PMC/Client of such claims.

12. Insurance

- 12.1. The Contractor shall provide, in the joint names of the PMC, Client Department and the Contractor, insurance covers in two parts, i.e. (a) from the start date to the completion date, and (b) for the Defect Liability period, in the amounts and deductibles stated in the Contract Data for the following events which are due to the Contractor's risks:
- a. loss of or damage to the Works, Plants and Materials;
 - b. loss of or damage to Equipment;
 - c. loss of or damage of property (except the Works, Plant, Materials and Equipment) in connection with the Contract;
 - d. Workman compensation policy to cover personal injury or death.
- 12.2. Policies and Certificates for insurance shall be delivered by the Contractor to the Engineer's approval before the Start Date. All such insurance shall provide for compensation to be payable in the types and proportions of currencies required to rectify the loss or damage incurred.
- 12.3. If the Contractor does not provide any of the policies and certificates required, the Engineer-in charge may effect the insurance which the Contractor should have provided and recover any such premiums which the PMC/Client Department has paid from the payments otherwise due to the Contractor or, if no payment is due, the payment of the premiums shall be a debt due.
- 12.4. Alterations to the terms of insurance shall not be made without the approval of the PMC.
- 12.5. Both parties shall comply with any conditions of the insurance policies.
- 12.6. Premium for all insurance policies shall be paid and borne by the Contractor and shall not be reimbursable. The Contractor shall provide to the Engineer-in-Charge all policies of insurance in original. These policies shall be fully executed and shall state

that the policies cannot be cancelled until completion of the Contract or completion of defects liability period and any extensions thereof. The Contractor shall obtain similar policies from all Sub-Contractors and thereby assume responsibility for any claims or losses to the PMC and Engineer-in-charge resulting from failure of any of the Sub-Contractors to obtain adequate insurance protection in connection with their work and shall indemnify and keep indemnified the PMC and Engineer-in-charge including their employees, officers, servants, agents and any other person moving in the premises, accordingly.

12.7. Unlimited liability: In addition to the liability imposed by law upon the Contractor for injury (including death) to persons or damage to property by reason of the negligence of the Contractor or his agents, which liability is not impaired or otherwise affected hereby, the Contractor hereby assumes liability for and agrees to save the PMC, Client/Department and Engineer-in-Charge including their employees, officers, servants, agents and any other person moving in the premises harmless and indemnifies them from every expense, liability or payment by reason of any injury (including death) to persons or damage to property suffered through any act or omission of the Contractor, his employees, agents, servants, workmen, suppliers or any of his Sub-Contractors, or any person directly or indirectly employed by any of them or from the conditions of the Site or any part of the Site which is in the control of the Contractor or his employees or any of his Sub-Contractors, or any one directly or indirectly employed by either of them or arising in any way from the Work.

12.8. All insurance claims, payable by the insurers, shall be paid to the PMC/Client Department which shall be released to the Contractor in installments as may be certified by the Engineer-in-charge for the purpose of rebuilding or replacement or repair of the works and/or goods destroyed or damaged for which payment was received from the insurers.

13. Liability for accidents and damages

13.1. Under the Contract, the Contractor shall be responsible for any loss or damage to the works under this contract until the works are completed and taken over in accordance with the Contract.

14. Time of Completion

14.1. Time is the essence of the contract. The time allowed for carrying out the Work as entered in the tender shall be strictly observed by the Contractor and shall be deemed to be of the essence of the Contract and shall be reckoned from the date of handing over the site to the Contractor. The Work shall proceed with due diligence until Final Completion. The Contractor shall prepare a Construction Programme with time schedule keeping in view the completion period stipulated for specific portions of the Work and also the overall completion time and submit the same for the approval of the Tendering authority after the receipt of letter of acceptance or selection notice. The approved work programme shall be made as part of the Contract agreement. The Contractor shall comply with this time schedule. In the event of the Contractor failing to comply with the overall and individual milestones contained in the time schedules, he shall be liable to pay liquidated damages as provided for in this Contract.

14.2. Completion Period: The Date of commencement will be the date of site handover or the 7th day after notification of award, whichever is later. The Completion period allowed is 100 days from the date of commencement.

The Milestone dates shall be those specified in the Contract Data or as mutually discussed and agreed. In case the Contractor fails to meet the above stipulated completion period, Contractor shall be liable to pay to the PMC/Client Department, liquidated damages as specified in Clause 15 of General Conditions of Contract. In addition to his own work in the overall time period, the Contractor shall provide for the works of other Sub-contractors and Vendors, including those employed directly by the PMC/ Engineer-in-Charge.

- 14.3. The contractor has to take over charge of the site by signing the order acceptance copy and commence the work within 7 days from the date of notification of award.
- 14.4. If the site is not taken over by the contractor by signing the order acceptance copy, Engineer will record the date of taking over as the seventh day from the date of notification of award unless otherwise decided.
- 14.5. The contractor has to resubmit the order acceptance copy duly signed within three days of above and commence the works
- 14.6. It shall be deemed that the contractor has taken over charge of the site on the seventh day from the date of notification of award irrespective of whether he has received the order or has resubmitted it with his signature as proof of acceptance. The work will be terminated at his risk and cost if the contractor does not submit the order acceptance copy and commence the work as required under 14.3.
- 14.7. Recovery towards risk and cost will be made from the performance guarantee, if the contractor does not turn up to take charge of the site within the time prescribed under 14.6, PMC/Client department reserves the right to terminate the contract and take actions including forfeit of bid security, performance security and blacklisting of the contractor.
- 14.8. The works shall be carried out in accordance with the programme submitted by the contractor and agreed to by the Agreement Authority at the time of executing agreement and updated subsequently with the approval of the Agreement Authority.

15. Liquidated damages (LD)

- 15.1. If the Contractor fails to maintain the required progress in terms of the agreed time and progress chart or to complete the work and clear the site on or before the date of completion of Contract or extended date of completion, he shall without prejudice to any other right or remedy available under the law to the PMC on account of such breach, pay as compensation, Liquidated damages @ 1(one) percent of the contract price per week of delay or part thereof. The aggregate of such compensation / compensations shall not exceed 10 (ten) percent of the contract value. This will also apply to items or group of items for which separate period of completion has been specified. The amount of compensation may be adjusted or set off against any sum payable to the contractor under this or any other contract with the PMC/Client department.
- 15.2. The Agreement Authority, if satisfied, that the work can be completed by the Contractor within a reasonable time after the specified time of completion, may allow further extension of time at its discretion as per clause-19. In the event of extension granted being with Liquidated Damages, the PMC will be entitled without prejudice to any other right or remedy available in that behalf, to recover from the Contractor as agreed damages equivalent to @ 1(one) percent of the contract price per week of delay or part thereof.

- 15.3. If the contractor achieves balance milestones, even though he has failed to achieve initial milestones, and the work has been completed in the specified/original time of completion, the PMC/Client Department may release the already levied liquidated damages at his sole discretion.
- 15.4. The Agreement Authority, if not satisfied that the works can be completed by the Contractor and in the event of failure on the part of the Contractor to complete work within further extension of time allowed as aforesaid, shall be entitled, without prejudice to any other right, or remedy available in that behalf, to terminate the contract.
- 15.5. The Agreement Authority, if not satisfied with the progress of the contract and in the event of failure of the Contractor to recoup the delays in the mutually agreed time frame, shall be entitled to terminate the contract
- 15.6. In the event of such termination of the contract as described in clauses 15.4 and 15.5 or both, the PMC, shall be entitled to recover Liquidated Damages up to ten percent (10%) of the contract value and forfeit the Performance Guarantee and Security Deposit made by the Contractor besides getting the work completed by other means at the risk and cost of the Contractor.
- 15.7. The Client/Department may waive the payment of compensation in the case of contracts where milestones are fixed, depending upon merit of the case, on request received from the Contractor with the recommendation of PMC if the entire work is completed within the date as specified in the Contract or as validly extended without stipulating any penalty.

16. Deleted

17. Contractor's default

- 17.1. If the Contractor shall neglect to execute the works with the diligence and expedition or shall refuse or neglect to comply with any reasonable orders given to him, in writing by the Engineer in connection with the works or shall contravene the provisions of the Contract, the Agreement Authority may give notice in writing to the Contractor to make good the failure, neglect or contravention complained of. Should the Contractor fail to comply with the notice within thirty (30) days from the date of service thereof, then and in such case the Agreement Authority shall be at liberty to employ other workmen and forthwith execute such part of the works as the Contractor may have neglected to do or if the Agreement Authority shall think fit, it shall be lawful for him, without prejudice to any other right he may have under the Contract, to take the works wholly or in part thereof and in that event the Agreement Authority shall have free use of all Contractor's equipment that may have been at the time on the site in connection with the works without being responsible to the Contractor for fair wear and tear thereof and to the exclusion of any right of the Contractor over the same, and the Agreement Authority shall be entitled to retain and apply any balance which may otherwise be due on the Contract by him to the Contractor, or such part thereof as may be necessary, the payment of the cost of executing the said part of the works or of completing the works as the case may be plus a fine of 20 percent of the value of work so carried out. If the cost of completing the works or executing a part thereof as aforesaid plus a fine of 20 percent of the value of work so carried out shall exceed the balance due to the Contractor, the Contractor shall pay such excess. Such payment of excess amount shall be independent of the liquidated damages for delay, which the Contractor shall have to pay if the completion of works is delayed. In addition, such action by the Agreement Authority as aforesaid shall not relieve the Contractor of his liability to pay liquidated damages for delay in completion of works as defined in clause 15. The

termination of the Contract under this clause shall not entitle the Contractor to reduce the value of the performance bank guarantee nor the time thereof. The performance guarantee shall be valid for the full value and for the full period of the Contract including Defects Liability Period.

17.2. If the Contractor fails to complete the work and the agreement is cancelled, the amount due to him on account of work executed by him, if payable, shall be paid to him only after due recoveries as per the provisions of the Contract and that too after alternative arrangements to complete the work has been made.

18. Delays by Client/Department/PMC or his authorised agent

18.1. In case the Contractor's performance is delayed due to any act of omission on the part of the PMC/Client/Department or his authorized agents, then the Contractor shall be given due extension of time for the completion of the works, to the extent such omission on the part of the Client/Department/PMC has caused delay in the Contractor's performance of his work. Regarding reasonableness or otherwise of the extension of time, the decision of the Engineer shall be final. The reasons for such delays shall be recorded in the hindrance register as per clause 19.2 and shall be certified by the Field Engineers in charge of the work.

18.2. Any delay in finalisation of mutual agreement in regard to any of the Contractor's claim against any act of omission on the part of the Client/Department/PMC or his authorised agents should not result in any work stoppage/further delay on the part of the Contractor.

19. Extension of time of completion

19.1. On happening of any events causing delay as stated hereinafter, the Contractor shall intimate immediately in writing to the Engineer-in-charge:

- a. Due to any reasons defined as Force Majeure.
- b. Non-availability of stores which are the responsibility of the Client/Department/PMC to supply.
- c. Non-availability or breakdown of tools and plant to be made available by the Client/Department/PMC.
- d. Inclement weather conditions
- e. Delay on the part of the Contractors or tradesmen engaged by the PMC/Client/Department not forming part of the Contract, holding up further progress of the work.
- f. Non-availability of design or detailed drawings or specifications time, which are to be made available by the PMC/Client/Department during progress of the work.
- g. Any other causes which, at the sole discretion of the PMC/Client/Department is beyond the control of the Contractor.

19.2. A "Hindrance Register" shall be maintained by the Engineer in Charge at site to record the various hindrances, as mentioned under item 19.1 above, encountered during the course of execution. The entries made in hindrance register are to be approved by the Engineer in charge. Contractor is permitted to sign the register and record his remarks.

- 19.3. The Contractor may request the Agreement Authority in writing for extension of time within 14 (fourteen) days of happening of such event causing delay stating also, if practicable, the period for which extension is desired. The Agreement Authority may, considering the eligibility of the request, give a fair and reasonable extension of time for completion of the work. Such extension shall be communicated to the Contractor in writing by the Agreement Authority through the Engineer-in-charge within one month of the date of receipt of such request. The Contractor shall however use his best efforts to prevent or make good the delay by putting his endeavours constantly as may be reasonably required of him to the satisfaction of the Engineer-in-charge. Related entries in the hindrance register shall also to be submitted along with the request for extension.
- 19.4. When the period fixed for the completion of the Contract is about to expire, the question of extension of the Contract may be considered at the instance of the Contractor or the PMC or the both. The extension will have to be by both party's agreement, expressed or implied.
- 19.5. In case the Contractor does not apply for grant of extension of time within 07 (Seven) days of hindrance occurring in execution of the work and the PMC wants to continue with the work beyond the stipulated date of completion for reason of the work having been hindered, the Engineer-in-charge at his sole discretion can grant provisional extension of time even in the absence of application from the Contractor. Such extension of time granted by the Engineer-in-charge is valid provided the Contractor accepts the same either expressly or implied by his actions before and subsequent to the date of completion. Such extension of time shall be without prejudice to PMC's right to levy compensation under the relevant clause of Contract.

20. Termination, suspension, cancellation & foreclosure of contract

- 20.1. The Agreement Authority shall, in addition to other remedial steps to be taken as provided in the conditions of Contract, be entitled to cancel the Contract in full or in part, if the Contractor
- a. makes default in proceeding with the works with due diligence and continues to do so even after a notice in writing from the Engineer-in charge, then on the expiry of the period as specified in the notice, or
 - b. commits default/breach in complying with any of the terms and conditions of the Contract and does not remedy it or fails to take effective steps for the remedy to the satisfaction of the Engineer-in charge, then on the expiry of the period as may be specified by the Engineer-in-charge in a notice in writing, or
 - c. fails to complete the work or items of work with individual dates of completion, on or before the date/dates of completion or as extended by the Agreement Authority, then on the expiry of the period as may be specified by the Engineer-in-charge in a notice in writing, or
 - d. shall offer or give or agree to give any person in the service of the PMC/Client Department or to any other person on his behalf any gift or consideration of any kind as an inducement or reward for act/acts of favour in relation to the obtaining or execution of this or any other Contract for the PMC, or
 - e. shall try to obtain a Contract from the PMC by way of ring Tendering or other non-bonafide method of competitive Tendering, or

- f. Transfers, sublets, assign the entire work or any portion thereof without the prior approval in writing from the Agreement Authority. The Agreement Authority may by giving a written notice, cancel such transfers or sublets or assignment.
- 20.2. The Agreement Authority shall in such an event give fifteen (15) days notice in writing to the Contractor informing his decision to do so.
- 20.3. The Contractor upon receipt of such notice shall discontinue the work on the date and to the extent specified in the notice, make all reasonable efforts to obtain cancellation of all orders and Contracts to the extent they are related to the work terminated and terms satisfactory to the PMC, stop all further sub-Contracting or purchasing activity related to the work terminated, and assist the PMC in maintenance, protection, and disposition of the works acquired under the Contract by the PMC.
- 20.4. The Contract shall stand terminated under the following circumstances unless the PMC is satisfied that the legal representatives of the individual Contractor or of the proprietor of the proprietary concern and in the case of partnership the surviving partners, are capable of carrying out and completing the Contract and the PMC shall in any way not be liable to payment of any compensation to the estate of deceased Contractor and/or to the surviving partners of the Contractor's firm on account of the termination of the Contract.:
- a. If the Contractor being an individual in the case of proprietary concern or in the case of a partnership firm any of its partners is declared insolvent under the provisions of insolvency act for the time being in force, or makes any conveyance or assignment of his effects or composition or arrangement for the benefit of his creditors amounting to proceedings for liquidation or composition under any insolvency act.
 - b. In the case of the Contractor being a employer, its affairs are under liquidation either by a resolution passed by the employer or by an order of court, not being a voluntary liquidation proceedings for the purpose of amalgamation or re-organisation, or a receiver or manager is appointed by the court on the application by the debenture holders of the employer, if any.
 - c. If the Contractor shall suffer an execution being levied on his/their goods, estates and allow it to be continued for a period of 21(twenty-one) days.
 - d. On the death of the Contractor being a proprietary concern or of any of the partners in the case of a partnership concern and the PMC/Client department is not satisfied that the legal representative of the deceased proprietor or the other surviving partners of the partnership concern are capable of carrying out and completing the Contract. The decision of the Agreement Authority in this respect shall be final and binding which is to be intimated in writing to the legal representative or to the partnership concern.
 - e. If the Contractor is an individual or a proprietary concern and the individual or the proprietor dies and if the Contractor is a partnership concern and one of the partners dies, then unless the PMC is satisfied that the legal representatives of the individual Contractor or of the proprietor of the proprietary concern and in the case of partnership the surviving partners, are capable of carrying out and completing the Contract the Agreement Authority shall be entitled to cancel the Contract as to its incomplete part without being in any way liable to payment of any compensation to the estate of deceased Contractor and/or to the surviving partners of the Contractor's firm on account of the cancellation of the Contract. The decision of the Agreement Authority that the legal representatives of the

deceased Contractor or surviving partners of the Contractor's firm cannot carry out and complete the Contract shall be final and binding on the parties. In the event of such cancellation the PMC shall not hold the estate of the deceased Contractor and/or the surviving partners of the estate of the deceased Contractor and/or the surviving partners of the Contractor's firm liable to damages for not completing the Contract.

20.5. On cancellation or on termination of the Contract, the Engineer-in-charge shall have powers

- a. to take possession of the site and any materials, constructional plant, implements, stores, etc. thereon.
- b. to carry out the incomplete work by any means at the risk of the defaulted Contractor.
- c. to determine the amount to be recovered from the Contractor for completing the remaining work or in the event the remaining work is not to be completed the loss/damage suffered, if any, by the PMC after giving credit for the value of the work executed by the Contractor up to the time of termination/cancellation less on account payments made till date and value of Contractor's materials, plant, equipment, etc., taken possession of after termination/cancellation.
- d. to recover the amount determined as above, if any, from any moneys due to the Contractor or any account or under any other Contract and in the event of any shortfall, the Contractor shall be called upon to pay the same on demand. The need for determination of the amount of recovery of any extra cost/expenditure or of any loss/damage suffered by the PMC shall not however arise in the case of termination of the Contract for death/demise of the Contractor as stated in clause.20.4 (d).
- e. The inventory of up to date work and balance stores at site, plant/machineries, equipments and any other property of contractor utilised for the work shall be taken on charge by the Department after combined survey with the Contractor or his authorised representative. If Contractor or his authorised representative is not appearing for combined survey after one week of giving notice, inventory shall be prepared by the Department in his absence and the Contractor is bound to accept the same.
- f. During the currency of execution of work, contractor shall not remove his resources without prior permission of Engineer-in charge.
- g. Additionally, the PMC will reserve the right to debar such defaulting Contractor from participating in future Tenders for a minimum period of one year

20.6. Suspension of work - The PMC shall have power to suspend the progress of the work or any part thereof and the Engineer-in-charge may direct the Contractor in writing to suspend the work, for such period and in such manner as may be specified therein, on account of any default on the part of the Contractor, or for proper execution of the work for reasons other than any default on the part of the Contractor, or on ground of safety of the work or part thereof. In the event of suspension for reason other than any default on the part of the Contractor, extension of time shall be allowed by the Agreement Authority equal to the period of such suspension plus an additional time period of 25% of the suspension period or 30 days whichever is less. The PMC/Client Department shall not be responsible for any liabilities if suspension or delay is due to some default on the part of the Contractor or his sub-Contractor. The work shall, throughout the stipulated period

of contract, be carried out with all due diligence on the part of the contractor. In the event of termination or suspension of the contract, on account of default on the part of the contractor, as narrated hereinbefore, the Performance Security Deposit and other dues of this work or any other work done under this PMC/Client Department shall be forfeited and brought under the absolute disposal of the PMC/Client Department provided, that the amount so forfeited shall not exceed 10% of the contract value.

- 20.7. Foreclosure of Contract in full or in part - If at any time after acceptance of the Bid, the PMC/Client Department decides to abandon or reduce the scope of the work for any reason whatsoever the PMC/Client Department, through its Engineer-in-charge, shall give notice in writing to that effect to the Contractor. In the event of abandonment/reduction in the scope of work,
- a. The Contractor shall, if required by the Engineer-in-charge, furnish to him books of accounts, papers, relevant documents as may be necessary to enable the Engineer-in-charge to assess the amount payable in terms of the contract, the Contractor shall not have any claim for compensation whatsoever either for abandonment or for reduction in the scope of work, other than those as specified above.
 - b. If the progress of the work or of any portion of the work is unsatisfactory, the Engineer-in-Charge, after giving the contractor 15 (fifteen) days' notice in writing, without cancelling or terminating the contract, shall be entitled to employ another agency for executing the job or to carry out the work departmentally or contractually through tendering process, either wholly or partly, debiting the contractor with cost involved in engaging another agency or with the cost of labour and the prices of materials, as the case may be. The certificate to be issued by the Engineer-in-Charge for the cost of the work so done shall be final and conclusive and the extra cost, if any, shall be borne by the contractor. However, when this clause is invoked, penalty will not be applicable.

21. No waiver of rights

- 21.1. Neither the inspection by the PMC/Client Department or the Engineer-in charge or Engineer's Representatives or any of their officials, employees or agents nor any order by the PMC/Client Department or the Engineer for payment of money or any payment for or acceptance of, the whole or any part of the works by the PMC/Client Department or the Engineer, nor any extension of time, nor any possession taken by the Engineer, inspection by PMC or his authorised representatives etc shall operate as a waiver of any provision of the Contract, or of any power herein reserved to the PMC/Client Department, or any right to damages herein provided, nor shall any waiver of any breach in the Contract be held to be a waiver of any other or subsequent breach.

22. Certificate not to affect right of PMC/Client Department and liability of contractor

- 22.1.No interim payment certificate of the Engineer, nor any sum paid on account, by the PMC/Client Department, nor any extension of time for execution of the works granted by the Engineer shall affect or prejudice the rights of the PMC/Client Department against the Contractor or relieve the Contractor of his obligations for the due performance of the Contract, or be interpreted as approval of the works done or of the equipment furnished and no certificate shall create liability for the PMC/Client Department to pay for alterations, amendments, variations or additional works not ordered, in writing, by the Engineer or discharge the liability of the Contractor for the payment of damages whether due, ascertained, or certified or not, or any sum against the payment of which he is bound to indemnify the PMC/Client Department, nor shall

any such certificate nor the acceptance by him of any sum paid on account or otherwise affect of prejudice the rights of the Contractor against the PMC/Client Department.

23. Grafts and commissions etc.

23.1. Any graft, commission, gift or advantage given, promised or offered by or on behalf of the Contractor or his partner, agent, officers, director, employee or servant or any one of his or their behalf in relation to the obtaining or to the execution of this or any other Contract with the PMC/Client Department, shall, in addition to any criminal liability which it may incur, subject the Contractor to the cancellation of this and all other Contracts and also to payment of any loss or damage to the PMC/Client Department resulting from any cancellation. The PMC/Client Department/Engineer-in charge shall then be entitled to deduct the amount so payable from any moneys otherwise due to the Contractor under the Contract.

24. Language and measures

24.1. All documents pertaining to the Contract including specifications, schedules, notices, correspondence, operating and maintenance instructions, drawings or any other writing shall be written in English language. The metric system of measurement shall be used exclusively in the Contract. Measurements, quantities, prices or rates and amounts shall have two digit precision.

25. Release of information

25.1. The Contractor shall not communicate or use in advertising, publicity, sales releases or in any other medium photographs or other reproduction of the works under this Contract, or descriptions of the site, dimensions, quantity, quality or other information, concerning the works unless prior written permission has been obtained from the PMC/Client Department.

26. Completion of contract

26.1. Unless otherwise terminated under the provisions of any other relevant clause, this Contract shall be deemed to have been completed at the expiration of the Defects Liability Period as provided for under the clause 46.

27. Enforcement of terms

27.1. The failure of either party to enforce at any time of the provisions of this Contract or any rights in respect thereto or to exercise any option herein provided, shall in no way be construed to be a waiver of such provisions, rights or options or in any way to affect the validity of the Contract. The exercise by either party of any of its rights herein shall not preclude or prejudice either party from exercising the same or any other right it may have hereunder.

28. Engineer's decision

28.1. In respect of all matters which are left to the decision of the Engineer including the granting or with holding of the certificates, the Engineer shall, if required to do so by the Contractor, give in writing a decision thereon.

28.2. If in the opinion of the Contractor, a decision made by the Engineer is not in accordance with the meaning and intent of the Contract, the Contractor may file with the Engineer within 15(fifteen) days after receipt of the decision, a written objection to the decision.

Failure to file an objection within the allotted time will be considered as acceptance of the Engineer's decision and the decision shall become final and binding.

28.3. The Engineer's decision and the filling of the written objection thereto shall be a condition precedent to the right to any legal proceedings. It is the intent of the agreement that there shall be no delay in the execution of the works and the decision of the Engineer as rendered shall be promptly observed.

29. Co-operation with other Contractors, Consultants & Engineers

29.1. The Contractor shall co-operate with the PMC/Client Department's other Contractors Consultants and consulting Engineers, if employed in the site, and freely exchange with them such technical information as is necessary for the satisfactory execution of works.

30. Variations or additions

30.1. No alterations, amendments, omissions, suspensions or variations of the works (hereinafter referred to as "Variation") under the Contract as detailed in the Contract documents, shall be made by the Contractor except as directed in writing by the Engineer, but the Engineer shall have full power subject to the provision hereinafter contained from time to time during the execution of the Contract, by notice in writing, to instruct the Contractor to make such variation without prejudice to the Contract. The Contractor shall carry out such variation and be bound by the same conditions as far as applicable as though the said variation occurred in the Contract documents. If any suggested variation would, in the opinion of the Contractor, if carried out, prevent him from fulfilling any of his obligations or guarantees under the Contract, he shall notify the Engineer thereof in writing and the Engineer shall decide forthwith, whether or not the same shall be carried out and if the Engineer confirm his instructions, Contractor's obligations and guarantees shall be modified to such an extent as may be mutually agreed. Any agreed difference in cost occasioned by any such variation shall be added to or deducted from the Contract price as the case may be.

30.2. In the event of the Engineer requiring any variation, such reasonable and proper notice shall be given to the Contractor to enable him to work his arrangements accordingly, and in cases where goods or materials are already prepared or any design, drawings of pattern made or work done requires to be altered, a reasonable and agreed sum in respect thereof shall be paid to the Contractor.

30.3. In any case in which the Contractor has received instructions from the Engineer as to the requirement of carrying out the altered or additional substituted work which either then or later on, will in the opinion of the Contractor, involve a claim for additional payments, the Contractor shall immediately and in no case later than ten (10) days, after receipt of the instructions aforesaid and before carrying out the instructions, advise the Engineer to that effect. But the Engineer shall not become liable for the payment of any charges in respect of any such variations, unless the specifications of the same shall be confirmed in writing by the Engineer.

30.4. If any variation in the works, results in reduction of Contract price, the parties shall, agree, in writing, so to the extent of any change in the price, before the Contractor proceeds with the change.

30.5. In all the above cases, in the event of a disagreement as to the reasonableness of the said sum, the decision of the Engineer shall prevail.

30.6. Notwithstanding anything stated above in this clause, the Engineer shall have the full power to instruct the Contractor, in writing, during the execution of the Contract, to vary

the quantities of the items or groups of items. The Contractor shall carry out such variations and be bound by the same conditions, as though the said variations occurred in the Contract documents. However, the Contract price shall be adjusted at the rates and the prices provided for the original quantities in the Contract.

31. Replacement of defective parts and materials

- 31.1. If during the progress of the works the Engineer shall decide and inform in writing to the Contractor, that any part of work or materials used therein is unsound or imperfect or has furnished any work is inferior than the quality specified, the Contractor on receiving details of such defects or deficiencies shall at his own expense within seven (7) days of his receiving the notice, or otherwise, within such time as may be reasonably necessary for making it good, proceed to alter, re-construct or remove such work and furnish fresh materials up to the standards of the specifications.
- 31.2. In case the Contractor fails to do so, the Engineer may on giving the Contractor seven (7) days' notice in writing of his intentions to do so, proceed to remove the portion of the works or materials so complained of and, at the cost of the Contractor, perform all such work or furnish all such equipment provided that nothing in this clause shall be deemed to deprive the PMC/Client Department of or affect any rights under the Contract which the PMC/Client Department may otherwise have in respect of such defects and deficiencies.
- 31.3. The Contractor's full and extreme liability under this clause shall be satisfied by the payments to the PMC/Client Department of the extra cost, of such replacement procured, including erection, as provided for in the Contract, such extra cost being the ascertained difference between the price paid by the PMC/Client Department for such replacements and the Contract price portion for such defective work and repayments of any sum paid by the PMC/Client Department to the Contractor in respect of such defective work. Should the PMC/Client Department not so replace the defective work or materials, the Contractor's extreme liability under this clause shall be limited to repayment of all sums paid by the PMC/Client Department under the Contract for such defective works or works using the defective materials.

32. Defence of suits

- 32.1. If any action in court is brought against the PMC/Client Department or Engineer or an officer or agent of the PMC/Client Department for the failure or neglect on the part of the Contractor to perform any acts, matters, covenants or things under the Contract, or for damage or injury caused by the alleged omission or negligence on the part of the Contractor, his agents, representatives or his sub-Contractors, workmen, suppliers or employees, the Contractor shall in all such cases indemnify and keep the PMC/Client Department, and the Engineer and/or his representative, harmless from all losses, damages, expenses or decrees arising out of such action.

33. Limitations of liabilities

- 33.1. The final payment by the PMC/Client Department in pursuance of the Contract shall mean the release of the Contractor from all his liabilities under the Contract. Such final payment shall be made only at the end of the Defect liability period as detailed in clause 46 and till such time as the Contractual liabilities and responsibilities of the Contractor, shall prevail. All other payments made under the Contract shall be treated as on account payments.

34. Taxes, Permits & Licenses

34.1. The Contractor shall be liable and pay all taxes, duties, levies, royalties etc lawfully assessed against the Contractor in pursuance of the Contract. In addition the Contractor shall be responsible for payment of all Indian duties, levies and taxes lawfully assessed against the Contractor for his personal income and property. This clause shall be read in conjunction with clause 3.3.6 of section Instruction to Bidders.

35. Payments

35.1. The payment to the Contractor for the performance of the works under the Contract will be made by the Client Department based on the advice of PMC as per the guidelines and conditions specified herein. All payment made during the Contract shall be on account payments only. The final payment will be made on completion of all the works and on fulfillment by the Contractor of all his liabilities under this contract and also after issue of Completion Certificate by the Agreement Authority.

35.1.1 The payment shall be made as under:-

The contractor can submit two running account bills during the work period and payment made as below:

- I. 80% of the bill value will be paid on each running account bill submitted by the contractor.
- II. Balance 20% will be paid along with the final bill only after issue of Work Completion certificate by Engineer In Charge/Officer In Charge of HLL Lifecare Ltd (Project Management Consultant).

35.2. All payments under the Contract shall be in Indian Rupees only.

35.3. All such interim payments shall be regarded as payment by way of advances against final payment only and shall not preclude the requiring of bad, unsound and imperfect or unskilled work to be rejected, removed, taken away and reconstructed or re-erected. Any certificate given by the Engineer-in-Charge relating to the work done or materials delivered forming part of such payment, may be modified or corrected by any subsequent such certificate(s) or by the final certificate and shall not by itself be conclusive evidence that any work or materials to which it relates is/are in accordance with the contract and specifications. Any such interim payment, or any part thereof shall not in any respect conclude, determine or affect in any way powers of the Engineer-in-Charge under the contract or any of such payments be treated as final settlement and adjustment of accounts or in any way vary or affect the contract.

35.4. Pending consideration of extension of date of completion, interim payments shall continue to be made as herein provided without prejudice to the right of the department to take action under the terms of this contract for delay in the completion of work, if the extension of date of completion is not granted by the competent authority.

35.5. The bill for a work shall be submitted only with the first tier quality control certificates and Test Result sheets for all items in the Bill as required by the relevant provisions of the PWD Quality Control Manual or as listed in the Contract Data.

35.6. The Contractor will be required to produce income-tax and sales tax clearance certificates before the final payment and release of Performance Security Deposits.

35.7 Tax Deduction: All statutory deductions like GST, Income Tax, Works Contract Tax, E.S.I., P.F. or any other government-imposed liabilities shall be borne by the Contractor (as applicable at the time of execution of job) and shall be deducted from each bill submitted by the Contractor.

36. Method of measurement and Bill Preparation:

36.1. All Works shall be measured for making payments to the Contractor. To evaluate Work under this Contract and instructed as per work order/change orders issued by the Engineer-in-Charge, the standard method of measurement in accordance with the Standards laid down by CPWD Specifications Vol-I and II or Bureau of Indian Standards (IS: 1200) shall be followed. However if definite methods of measurements are stipulated in the Schedule of Rates or Specifications, then the same shall supersede BIS methods and shall be followed. In the event of any dispute with regard to the method of measurement of any work, the decision of the Engineer-in-Charge shall be final and binding and no extra claims shall be entertained or allowed at any stage in this regard.

36.2. The bills shall be prepared by the contractor/Engineer-in-charge as per the procedure laid down in CPWD Manual and amendments thereof if any.

36.3 The measurements shall be entered in a Computerized Measurement Book having pages of A-4 size as per the format of the PMC so that a complete record is obtained of all the items of works performed under the contract. It should be submitted by the contractor to the PMC after verification and certification by the Engineer-in-Charge or his authorized representative, duly bound, with its pages machine numbered, should be 100% correct, and no cutting or over-writing in the measurements would thereafter be allowed.

- a. All such measurements and levels recorded by the contractor or his authorized representative from time to time, during the progress of the work, shall be got checked by the contractor from the Engineer-in-Charge or his authorized representative as per interval or program fixed in consultation with Engineer-in-Charge or his authorized representative. After the necessary corrections made by the Engineer-in-Charge, the measurement sheets shall be returned to the contractor for incorporating the corrections and for resubmission to the Engineer-in-Charge for the dated signatures by the Engineer-in-Charge and the contractor or their representatives in token of their acceptance.
- b. The final, fair, computerized measurement book given by the contractor, duly bound, with its pages machine numbered, should be 100% correct, and no cutting or over-writing in the measurements would thereafter be allowed. If at all any error is noticed, the contractor shall have to submit a fresh computerized MB with its pages duly machine numbered and bound, after getting the earlier MB cancelled by the PMC. Thereafter, the MB shall be taken in the PMC Office records, and allotted a number as per the Register of Computerised MBs. This should be done before the corresponding bill is submitted to the Client Office for payment. The contractor shall submit two spare copies of such computerized MB's for the purpose of reference and record by the various officers of the PMC/Client department.
- c. It is also a term of this contract that checking and/or test checking the measurements of any item of work in the measurement book and/or its payment in the interim, on account of final bill shall not be considered as conclusive evidence as to the sufficiency of any work or material to which it relates nor shall it relieve the contractor from liabilities from any over measurement or defects noticed till completion of the defects liability period.

37. Covering up:

37.1. The Contractor shall give at least 24 hours clear notice in writing to the Engineer-in-Charge before covering up any of the Work in foundations or any other such areas in order that inspection of the Work may be carried out for maintaining proper quality control. In the event of the Contractor failing to provide such notice he shall, at his own expense, uncover such Work as required to allow the inspection to be taken and thereafter shall reinstate the Work to the satisfaction of the Engineer-in-Charge. Each stage of all hidden works shall be approved by the Engineer-in charge before executing the next stage.

38. Rectification of improper work noticed

38.1. If it shall appear to the Engineer-in-Charge during the progress of the Work that any work has been executed with unsound, imperfect or unskillful workmanship or with materials of any inferior description or that any materials or articles provided by the Contractor for the execution of the Work are unsound or of a quality inferior to that contracted for or otherwise not in accordance with the Contract, the Contractor shall, on demand in writing from the Engineer-in-Charge specifying the work, materials or articles complained of, notwithstanding that the same may have been passed and certified, forthwith rectify or remove and reconstruct the work so specified in whole, or in part as the case may require or as the case may be, remove the materials or articles so specified and provide other proper and suitable materials or articles at his own proper charge and cost and in the event of his failing to do so within a period so specified by the Engineer-in-Charge in his demand aforesaid, the Engineer-in-Charge may rectify or remove and re-execute the work or remove and replace with others, the materials or articles complained of as the case may be at the risk and expense in all respects of the Contractor, and deduct the expenses from the Performance Security Deposit any sums that may be due at any time thereafter to the Contractor or from his performance guarantee.

39. Change orders (Approval for Variations)

39.1. PMC/Client Department reserves the right to alter the Scope of Work (See Clause 10 and 30) and consequently the Contract Price shall be suitably adjusted for such changes by applying the approved rates. All change orders shall be issued by the Engineer-in-Charge and the onus shall be on the Contractor to obtain such prior written consent of the Engineer-in-Charge.

39.2. There shall be an order in writing to execute the extra item of work duly signed by the Agreement Authority before its commencement.

39.3. If the contractor finds, after examining the specifications and plans that extras are involved, he should give notice to the Engineer-in charge to this effect and shall proceed with the execution of the extra item only after receiving instructions in writing from Engineer-in charge and Agreement Authority.

39.4. Extra items may be classified as new, additional, substituted or altered items, depending, on their relation or otherwise to the original item or items of work.

39.5. The rates for extra items shall be worked out as below

39.5.1. In the case of all extra items whether altered or substituted, for which similar items exist in the contract, the rates shall be derived from the original item by appropriate adjustment of cost of affected components. The percentage excess or deduction of the contract rate for the original item with reference to the estimated rate shall be

applied in deriving the rates for such items. The Engineer in charge's interpretation as to what is a similar class of work shall be final and binding on the Contractor.

39.5.2. In the case of extra items, whether altered or substituted, for which similar items do not exist in the contract, the rates shall be arrived at on the basis of provision of standard data Book and schedule of rates 2016 of CPWD after applying the contractor's quoted percentage above or below.

39.5.3. In the case of extra items, whether additional altered or substituted, for which the rates cannot be derived from similar items in the contract, and only partly from similar items in the contract, and only partly from the CPWD rates, the rates for such part of items as are not covered in the schedule of rates shall be determined by the Project Management Consultant on the basis of the prevailing market rates giving due consideration to the analysis of the rate furnished by the Contractor with supporting documents, including contractor's profit. For the other part of the items the rates can be derived from the recent schedule of rates of C.P.W.D.

39.5.4. In the case of extra item whether additional, altered, substituted, for which the rates cannot be derived either from similar item of work in the contract or from the CPWD schedule of rates, the contractor shall within 14 days of the receipt of order to carry out the said extra item of work, communicate to the Project Management Consultant the rate which he proposes to claim for the item, supported by analysis of the rate claimed and the Project Management Consultant shall within one month thereafter, determine the rate on the basis or the market rate giving due consideration to the rate claimed by the contractor.

39.5.5. In all the above cases, the approved rates for extra, additional, altered or substituted items shall not exceed the rate which is arrived on the basis of the prevailing local market rates at the time of ordering or executing the extra item whichever is earlier.

39.5.6. Deleted

39.5.7. Wherever, the term "tender excess or tender deduction" appears, it shall mean the overall percentage variation of estimated cost and agreed amount of contract.

39.6. Deleted

40. Price Adjustment

40.1. This clause is applicable for works which have original time of completion more than 18 months

40.2. Contract price shall be adjusted for increase or decrease in rates and prices beyond the base price(s) of labour, materials, plant and equipment spares, fuels and lubricants as indicated in the Contract Data in accordance with the following principles, procedures and as per formula given in the Special conditions of contract.

- a. The price adjustment shall apply for the work done from the start date up to end of the initial intended completion date or extensions granted by the Engineer-in-charge and shall not apply to the work carried out beyond the stipulated time for reasons attributions to the contractor.
- b. The price adjustment shall be determined during each month from the formula given in the Special conditions of contract.

40.3. To the extent that full compensation for any rise or fall in costs to the contractor is not covered by the provisions of this or other clauses in the contract, the unit rates and prices included in the contract shall be deemed to include amounts to cover the contingency of such other rise or fall in costs.

41. Deductions for uncorrected work:

41.1. If the Engineer-in-Charge deems it inexpedient to get corrected or rectified any work of the Contractor which is defective or damaged or of substandard quality or is generally not in accordance with the Contract Documents, then an equitable and appropriate deduction shall be made thereof from the Contract Price, and the Engineer-in-Charge's decision in this respect shall be final and binding on the Contractor.

41.2. Furthermore if, by reason of any accident, or failure, or other event occurring to, in or in connection with the Work, or any part thereof, either during the execution of the Work or during the Defects Liability Period, any remedial or other work or repair shall, in the opinion of the Engineer-in-Charge, be urgently necessary for the safety of the Work, or any part thereof, and the Contractor is unable or unwilling to immediately and at once do such work or repair, the Engineer-in-Charge may employ and pay other persons or agencies to carry out such work or repair as the Engineer-in-Charge may consider necessary. If the work or repair so done by other persons or agencies work which, in the opinion of the Engineer-in-Charge, the Contractor was liable to do at his own expense under the Contract, then all expenses incurred by the PMC/Client Department / Engineer-in-Charge in connection with such work or repair shall be recovered from the Contractor and shall be deducted by the PMC/Client Department / Engineer-in-Charge from any money that may be payable or that may become payable to the Contractor or from the Contractor's performance Guarantee/Security Deposit.

41.3. The defective or uncorrected work of the Contractor at any stage (during or after completion of work) may adversely affect or damage the work of other Vendors. Contractor shall at his own cost immediately rectify, correct or replace both his defective work as well as the work of the other Vendors so damaged, within the time period stipulated by the Engineer-in-Charge, so as not to effect the progress and quality of other Vendor's work. In case the Contractor fails to do the necessary corrections to the satisfaction of Engineer-in-Charge or unduly delays the correction work, then the Engineer-in-Charge shall be at liberty to get the correction work done and if the correction work is not possible, then any extra work necessary to cover the defect or damage, done through same / any other Vendor at Contractor's cost.

41.4. Actual costs including any incidentals thereof incurred by the Engineer-in-Charge on such corrections / extra works shall be recovered from the payments or any amounts due to the Contractor.

42. Virtual completion of works:

42.1. The Contractor shall complete the Works by the intended date of completion. In case Extension of Time has been granted, the extended date of completion shall be considered. The Works shall be considered as Virtually Complete only upon satisfactory correction of all defects notified by the Engineer-in-charge, and only after the Work has been completed in every respect in conformity with the Contract Documents and after all the systems and services have been tested and commissioned, and after the Site has been cleared and the Work cleaned in accordance with Clause 78 and when the Agreement Authority on a report by the Engineer-in-Charge have certified in writing that the Work is Virtually Complete. The virtual completion certificate shall be issued by the Engineer-in charge within 15 days of final measurement. The Defects Liability Period shall commence from the date of Virtual Completion in the virtual completion certificate issued by the Agreement Authority.

42.2. Should, before Virtual Completion, the PMC/Client Department / Engineer-in-Charge decide to occupy any portion of the Work or use any part of any equipment, the same shall not constitute an acceptance of any part of the Work or of any equipment, unless so stated in writing by the Engineer-in-Charge.

42.3. Prior to the issue of the Virtual Completion Certificate, the Contractor shall submit and hand-over to the Engineer-in-Charge the keys to all locks, all operation and maintenance manuals for systems and services, material reconciliation statements, warranties, as built drawings, any spares called for in the Contract, and everything else necessary for the proper use and maintenance of the Work complete with all systems and services.

42.4. It is clarified that all materials whether PMC/Client Department supplied or not shall be procured by the contractor at his own cost for carrying out correction work. No charges shall be paid on this account.

43. Programme chart / milestones:

43.1. The Contractor should strictly adhere to the agreed milestones, if any for the work. If the milestones are not achieved by the Contractor, the Contractor shall pay the PMC/Client Department liquidated damages as per clause 15 of GCC. However, release of interim Liquidated Damages can be considered in case the very next Milestone is achieved on time. Extension of time for any milestone if allowed has to be obtained in writing from the Agreement authority well in advance of completion dates.

44. Penalty / fine for non-compliance of safety codes & labour laws:

44.1. If the Engineer-in-Charge notifies the Contractor of non-compliance with safety codes as in Clause no. 67 and 68 and the labour laws etc. Contractor shall immediately if so directed or in any event not more than 10 (ten) hours after receipt of such notice, make all reasonable effort to correct such non-compliance and to ensure that there is no reoccurrence of such non-compliance.

44.2. Deleted

45. Guarantees:

45.1. The Contractor understands and agrees that the Engineer-in-Charge is expressly relying and will continue to rely on the skill and judgment of the Contractor in executing the Work and remedying any defects in the Work. The Contract represents and warrants that :-

- a. The Contractor shall perform the Work in a timely manner, in strict accordance with the Contract Documents, and consistent with generally accepted professional, construction and construction-supervision practices and standards provided by an experienced and competent professional contractor and construction supervisor rendered under the same or similar circumstances.
- b. The Contractor is and will be responsible to the Engineer-in-Charge for the acts and omissions of his Sub-Contractors and their respective employees, agents and invitees and all the persons performing any of the Work on behalf of the Contractor.

- c. Besides the guarantees required and specified elsewhere in the Contract Documents, the Contractor shall in general guarantee all work executed by the Contractor and his Sub-Contractors for Defects Liability Period from the date of issue of the Virtual Completion Certificate. Those parts of the Work or equipment or installations, for which extended guarantee periods are stipulated elsewhere in the Contract Documents, shall be guaranteed for such periods that are so stipulated. The duration of the Defects Liability Period, unless specified otherwise, shall be the extent of length of such guarantee periods.

45.2. The Contractor represents, warrants and guarantees to Engineer, inter alias that:

- a. The execution of the Work shall be approved and capable of use, operation, performance and maintenance for accomplishing the purpose for which it has been built and acquired.
- b. The Work shall comply with the Specifications, Drawings, and other Contract Documents and that quality standards as per the CPWD Quality Control Manual shall be maintained.
- c. The Work shall, for Defect Liability Period from the date of issue of the Virtual Completion Certificate, be free from all defects and the Work shall be of structural soundness, durability, ease of maintenance, weather tightness etc.
- d. The materials, workmanship, fabrication and construction shall be of the specified and agreed quality and all materials shall be new.
- e. The Work performed for the Engineer-in-Charge shall be free from all liens, charges, claims of whatsoever nature from any party other than the Engineer-in-Charge.

45.3. Where, during such guarantee periods as mentioned above, any material or equipment or workmanship or generally any item of work fails to comply or perform in conformity with the requirements stipulated in the Contract Documents or in accordance with the criteria and provisions of the guarantee, the Contractor shall be responsible for and shall bear and pay all costs and expenses for replacing and/or rectifying and making good such materials, equipment, workmanship, and items of work and, in addition, the Contractor shall be also responsible for and shall bear and pay all costs and expenses in connection with any damages and/or losses suffered as a consequence of such failure.

45.4. All guarantees required under the Contract shall be in the format approved by the Engineer-in-Charge and submitted to the Engineer-in-Charge by the Contractor when requesting certification of the final bill.

46. Defects liability:

46.1. The Defect Liability Period shall be as mentioned in the contract data.

46.2. Maintenance by contractor during defects liability period: All defective items of work and defects noticed and brought to the attention of the Contractor by the Engineer in writing during the Defects Liability Period shall be promptly and expeditiously attended to and replaced and/or rectified and made good by the Contractor at his own cost, to the complete satisfaction of the Engineer-in-Charge.

46.3. Replacement and/or rectification and making good by contractors of all defective materials, equipment and/or workmanship during defects liability period: The Contractor shall replace and/or rectify and make good, at his own cost, and to the satisfaction of the Engineer-in-Charge, all defective items of work and defects arising, in the opinion of the Engineer-in-Charge, from materials, equipment, and/or workmanship not performing or

being not in accordance with the Drawings or Specifications or the instructions of the Engineer-in-Charge or other Contract Documents or the best engineering and construction practices, and which may appear or come to notice within Defects Liability Period after Virtual Completion of the Work. Any item, material or matter repaired or replaced shall receive a new Defects Liability Period of like duration beginning upon the date the repaired or replaced item, material or matter is returned for use to the Engineer-in-Charge, provided that the aggregate guarantee period shall not exceed **24 months**. The Contractor shall be also liable for all costs associated with damages and/or losses which are a consequence of such defective items of work and defects, and such costs shall be recouped by Engineer-in-Charge /Agreement Authority from the Contractor and shall be recovered from the Performance Security Deposit held and/or from the Contractor's final bill (if the final bill has not been certified and paid for at the time), or the same would otherwise be recovered from the Contractor. Should the Performance Security Deposit held (and the amount in respect of the final bill if it has not been certified and paid for at the time) be insufficient to meet such costs, damages, losses and expenses, as determined by the Engineer-in-Charge, then the Contractor shall be legally bound to pay the balance amount due under the claim to the Engineer-in-Charge within one month of receiving notification to that effect from the Engineer-in-Charge. In the event of failure on the part of the Contractor to pay the balance amount due within one month as stated above, the Engineer-in-Charge shall be entitled to invoke the performance bond and the Contractor shall raise no objection in this regard. In respect of those parts of the Work for which longer guarantee periods are stipulated elsewhere in the Contract Documents, the Defects Liability Period for such parts of the Works shall be until the end of the respective guarantee period that is stipulated for each such part. No payment shall be made to the contractor on this account.

46.4. All the material whether PMC/Client Department supplied or not shall be supplied by the Contractor at his own cost for undertaking any correction/rectification/replacement of defective/damaged or uncorrected works.

47. Final completion of the work :

47.1. The Work shall be considered as finally complete at the end of the Defects Liability Period subject to the Contractor having replaced and/or rectified and made good all the defective items of work and defects and hand over the Work in accordance with clause above, to the satisfaction of the Engineer-in-Charge, and provided that the Contractor has performed all his obligations and fulfilled all his liabilities under the Contract, and when the Agreement Authority has certified in writing that the Work are finally complete. Such Final Completion in respect of those parts of the Work, for which extended guarantee periods are stipulated elsewhere in the Contract Documents, shall be achieved at the end of such stipulated guarantee periods.

48. Taking over of the works

48.1. The Contractor shall be responsible to maintain all his works till completion of the Defects Liability Period and to handover the work to the PMC/Client. In this regard the works would be jointly inspected by a team comprising of representatives of Contractor and the Engineer-in-Charge, for noting any discrepancy, defect, shortcomings. Within the time period specified by the Engineer-in-Charge the Contractor shall rectify, correct or replace the defective works so noted during the joint inspection, at his own cost to the satisfaction of the Engineer-in-Charge. On acceptance of the Contractor's work, the contractor shall prepare the inventory of his works, and hand over the Work & the inventory to the PMC/Client Department.

- 48.2. During carrying out the rectification, correction or replacement works as mentioned above the Contractor shall take all necessary precautions to safeguard the existing finishing and works of other Vendors against any damage. In case the works of other Vendors are damaged by the Contractor while undertaking the rectification / replacement work, the Contractor shall rectify / replace the works so damaged at his own cost to the satisfaction of the Engineer-in-Charge.
- 48.3. On failure of the contractor to rectify, correct or replace the defective works or on undue delay on part of the contractor for the same, the Engineer-in-Charge shall be at liberty to undertake the correction works by itself or through any Vendor at the Contractor's cost. All such costs including any incidentals thereof incurred by the Engineer-in-Charge shall be recovered from the Contractor's payments or from any amounts due to the Contractor.
- 48.4. Subject to clause 42 of this section, upon the issue of virtual completion certificate, the Client/Department may take over the completed work for intended use. Such taking over of the works prior to completion of the Defects Liability Period by the PMC/Client Department shall not discharge the contractor of his responsibilities for the balance Defects Liability Period and the Defects Liability Period shall remain in force till completion of Defects Liability Period.
- 48.5. On removal of all the defects and handing over to the PMC/Client Department upon successful completion of the Defects Liability Period by the Contractor, the Engineer-in-Charge shall issue the Final Completion Certificate to the contractor and the Defects Liability Period shall deemed to be complete.

49. Force majeure

- 49.1. Force Majeure is herein defined as any cause which is beyond the control of the Contractor or the PMC/Client Department as the case may be which they could not foresee or with a reasonable amount of diligence could not have foreseen and which substantially affect the performance of the Contract, such as:
- a. Natural phenomena, including but not limited to floods, draughts, earthquakes and epidemics:
 - b. Acts of any government, including but not limited to war, declared or undeclared, priorities, quarantines, embargoes,
- 49.2. Provided either party shall within fifteen (15) days from the occurrence of such a cause notify the other in writing of such causes.
- a. The contractor will advise, in the event of his having resort to this clause by a registered letter duly certified by the local chamber of commerce or statutory authorities, the beginning and end of the clause of delay, within fifteen days of the occurrence and cessation of such force majeure condition.
 - b. For delays arising out of Force Majeure, the contractor will not claim extension in completion date for a period exceeding the period of delay attributable to causes of Force Majeure and neither PMC/Client Department nor the Contractor shall be liable to pay extra costs (like increase in rates, remobilization advance, idle charges for labour and machinery etc.) provided it is mutually established that the Force Majeure conditions did actually exist.

- c. If any of the Force Majeure conditions exists in the place of operation of the bidder even at the time of submission of the bid he will categorically specify them in the bid and state whether they have been taken into consideration in their bids.

49.3. The Contractor or the PMC/Client Department shall not be liable for delays in performing his obligations resulting from any force Majeure cause as referred to and/or defined above. The date of completion will, subject to hereinafter provided, be extended by a reasonable time even though such cause may occur after Contractor's performance of his obligations has been delayed for other causes.

50. Intellectual property rights:

50.1. All communications, whether written or oral, including but not limited to this Contract, its Annexure, Drawings, data sheets, Specifications, bills of material, sketches, calculations, designs and all other materials shall be treated as confidential and shall be the exclusive property of the Client Department unless otherwise agreed in writing and must be given to the Client Department upon request, but in any event all such materials shall be delivered to the Engineer-in-Charge upon termination/expiry of this Contract.

50.2. The Contractor agrees that it and its employees, agents, Sub-Contractors and consultants shall not (without the prior written consent of the PMC/Client Department) during the term of this Contract or thereafter, disclose, make commercial or other use of, give or sell to any person, firm or corporation, any information received directly or indirectly from the Engineer-in-Charge or acquired or developed in the course of the Work or this Contract, including by way of example only, ideas, inventions, methods, designs, formulae, systems, improvements, prices, discounts, business affairs, trade secrets, products, product specifications, manufacturing processes, data and know-how and technical information of any kind whatsoever unless such information has been publicly disclosed by authorised officials of the PMC/Client Department. The Contractor agrees that prior to assigning any employee or agent or hiring any Sub - Contractor or consultant to work on this Work, such employee, agent, Sub-Contractor or consultant shall be required to execute a document containing in substance and form, a confidentiality provision similar to this provision.

50.3. The Contractor shall not, without the Engineer-in-Charge's prior consent:

- a. Take any photographs or videos of the Work (or any part thereof) for use otherwise than in connection with carrying out and completion of the Work;
- b. Write for publication, or cause, information or comment or pictures about the Work;
- c. Supply to any third person such as actual and prospective clients, contractors, publishers, other interested parties and the like, the designs and any articles or information relating to the Work; and
- d. Give interviews to the press including television, radio print and the like regarding the Work or the Contractor's involvement in the Work.

50.4. Notwithstanding the foregoing, this provision shall not limit the obligation of the Contractor to take photographs and/or videos on a regular basis for the purpose of providing the progress reports and other communications to the Engineer/PMC.

50.5. The Contractor, Sub-Contractors and their respective employees, representatives, agents, servants, workmen and suppliers shall not, during or after the termination/expiry of this Contract, disclose any information pertaining to this Contract or the Work to any person without the prior written consent of the Engineer-in-Charge except when called upon to do so by a valid and lawful direction or order of a statutory or Government

authority or an order of a court of law or where any of the parties require production of this document and related information for establishing their respective legal rights.

51. Governing law:

51.1. The governing Law of the Contract shall be Indian law.

52. Standards of conduct:

52.1. The Contractor, in performing its obligations under this Contract, shall establish and maintain appropriate business standards, procedures and control, including those necessary to avoid any real or apparent impropriety or adverse impact on the interests of the PMC/Engineer-in-Charge. The PMC / Engineer-in-Charge will in no event reimburse the Contractor for any costs incurred for purposes inconsistent with such policies.

52.2. Compliance with Laws, Rules and Regulations: Contractor represents, warrants, certificates and covenants that in connection with performance under this contract that:

- a. It shall, and the Work to be provided hereunder shall, comply with all applicable Local, National, and Central Laws, rules and regulations, including but not limited to those governing building/road constructions, environmental, safety of persons and property, Employee State Insurance, workmen compensation, Provident Fund and applicable industrial/labour laws, and land development laws, rules and regulations.
- b. No services provided hereunder will be produced using forced, indentured or convict labour or using the labour of persons in violation of the minimum working age law in the country where the Work are rendered;
- c. It shall comply with all laws regarding improper or illegal payments, gifts or gratuities; and Contractor agrees not to pay, promise to pay or authorize the payment of any money or anything of value, directly or indirectly, to any person or entity for the purpose of illegally or improperly inducing a decision or obtaining or retaining business or any advantage in connection with this Contract;
- d. It has not paid or provided and shall not pay, any gratuity for the benefit of any agent, representative or employee of the PMC other than in accordance with the PMC's applicable policies; and
- e. It has not, and shall not, engage in any sharing or exchange of prices, costs or other competitive information or take any other collusive conduct with any third party supplier or bidder in connection with the preparation or submission of any bid or proposal to the Engineer-in-Charge or the negotiation of this Contract.
- f. It will also comply with all rules and regulations of the PMC which may be in effect at the Facility site regarding employment, passes, badges, smoking, fire prevention, safety and conduct or property. On behalf of the Engineer-in-Charge, Contractor shall request and monitor that such is observed by any Contractor, subcontractors, vendors and each of their employees.

52.3. Salient Features of Some Major Labour Laws (Applicable to the establishments engaged in construction work)

52.3.1. Workmen Compensation Act 1923: The Act provides for compensation in case of injury by accident arising out of and during the course of employment.

- 52.3.2. Payment of Gratuity Act 1972: Gratuity is payable to an employee under the Act on satisfaction of certain conditions on separation if an employee has completed 5 years' service or more or on death the rate of 15 days wages for every completed year of service. The Act is applicable to all establishments employing 10 or more employees.
- 52.3.3. Employees P.F. and Miscellaneous Provision Act 1952: The Act Provides for monthly contributions by the PMC plus workers @ 10% or 8.33%. The benefits payable under the Act are:
- a. Pension or family pension on retirement or death, as the case may be.
 - b. Deposit linked insurance on the death in harness of the worker.
 - c. Payment of P.F. accumulation on retirement/death etc.
- 52.3.4. Maternity Benefit Act 1951: The Act provides for leave and some other benefits to women employees in case of confinement or miscarriage etc.
- 52.3.5. Contract Labour (Regulation & Abolition) Act 1970: The Act provides for certain welfare measures to be provided by the Contractor to contract labour and in case the Contractor fails to provide, the same are required to be provided, by the PMC by Law. The Contractor is required to take license from the designated Officer. The Act is applicable to the establishments of the Contractor for the PMC/Client Department if they employ 20 or more contract labour.
- 52.3.6. Minimum Wages Act 1948: The PMC/Client Department is supposed to pay not less than the Minimum Wages fixed by appropriate Government as per provisions of the Act if the employment is a scheduled employment. Construction of Buildings, Roads, Bridges, Runways etc are scheduled employments.
- 52.3.7. Payment of Wages Act 1936: It lays down as to by what date the wages are to be paid, when it will be paid and what deductions can be made from the wages of the workers.
- 52.3.8. Equal Remuneration Act 1979: The Act provides for payment of equal wages for work of equal nature to Male and Female workers and for not making discrimination against Female employees in the matters of transfers, training and promotions etc.
- 52.3.9. Payment of Bonus: Minimum bonus shall be paid as per the State Government rules prevailing during the time of work.
- 52.3.10. Industrial Disputes Act 1947: The Act lays down the machinery and procedure for resolution of Industrial disputes, in what situations a strike or lock-out becomes illegal and what are the requirements for laying off or retrenching the employees or closing down the establishment.
- 52.3.11. Industrial Employment (Standing Orders) Act 1946: It is applicable to all establishments employing 100 or more workmen (employment size reduced by some of the States and Central Government to 50). The Act provides for laying down rules governing the conditions of employment by the PMC/Client Department on matters provided in the Act and get the same certified by the designated Authority.
- 52.3.12. Trade Unions Act 1926: The Act lays down the procedure for registration of trade unions of workmen and PMC/Client Department. The Trade Unions

registered under the Act have been given certain immunities from civil and criminal liabilities.

52.3.13. Child Labour (Prohibition & Regulation) Act 1986: The Act prohibits employment of children below 14 years of age in certain occupations and processes and provides for regulation of employment of children in all other occupations and processes. Employment of Child Labour is prohibited in Building and Construction Industry.

52.3.14. Inter-State Migrant workmen's (Regulation of Employment & Conditions of Service) Act 1979: The Act is applicable to an establishment which employs 5 or more interstate migrant workmen through an intermediary (who has recruited workmen in one state for employment in the establishment situated in another state). The Inter-State migrant workmen, in an establishment to which this Act becomes applicable, are required to be provided certain facilities such as housing, medical aid, travelling expenses from home upto the establishment and back, etc.

52.3.15. The Building and Other Construction workers (Regulation of Employment and Conditions of Service) Act 1996 and the Cess Act of 1996: All the establishments who carry on any building or other construction work and employs 10 or more workers are covered under this Act. All such establishments are required to pay cess at the rate not exceeding 1% of the cost of construction as may be modified by the Government. The PMC/Client Department of the establishment is required to provide safety measures at the Building or construction work and other welfare measures, such as Canteens, First-Aid facilities, Ambulance, Housing accommodations for workers near the work place etc. The PMC/Client Department to whom the Act applies has to obtain a registration certificate from the Registering Officer appointed by the Government.

52.3.16. Factories Act 1948: The Act lays down the procedure for approval at plans before setting up a factory, health and safety provisions, welfare provisions, working hours, annual earned leave and rendering information regarding accidents or dangerous occurrences to designated authorities. It is applicable to premises employing 10 persons or more with aid of power or 20 or more persons without the aid of power engaged in manufacturing process.

53. Warranty as to documents submitted to PMC audit:

53.1. The Contractor represents that all documents, including invoice, vouchers, financials to settlements, billings and other reports submitted or to be submitted by the Contractor to the Engineer-in-Charge in support of an application payment are true, correct, complete and accurate in all respects. Upon request of the Engineer-in-Charge, the Contractor agrees to cooperate fully with the Engineer-in-Charge and the field Engineers in the conduct of a Technical Audit for the Work by an independent agency entrusted by the Agreement Authority. The Contractor accepts that the contract / work shall be subject to the technical audit by an independent technical auditor appointed by the Agreement Authority to audit the quality and quantities of the works done by the contractor, and agrees to render all necessary assistance to such agencies / professionals, whose reports / assessments shall be final and binding. Contractor shall fulfil the requirements as per the auditors assessments at his own cost within the time stipulated by the Engineer-in-Charge.

54. Changes in Contractor's constitution:

54.1. Where the contractor is a Partnership, prior approval in writing shall be obtained from the Engineer-in-Charge before any change is made in the Constitution of the partnership.

54.2. Where the Contractor is an individual or a Hindu Undivided Family business, such written approval from the Agreement authority shall likewise be obtained before Contractor enters into any partnership agreement in which the partnership would have the right to carry out the work previously to be undertaken by the Contractor.

54.3. If such written prior approval is not obtained by the Contractor, appropriate action shall be taken by the Agreement authority as per the contract terms and conditions.

55. Grounds for withholding payments:

55.1. The Engineer-in-Charge may withhold the whole or part of any compensation due to the Contractor to the extent necessary to protect the PMC from any loss on account of any breach of Contractor's obligations under the Contract. When the cause for withholding is rectified, such amounts then due and owing shall be paid or credited to the Contractor.

CONTRACTOR'S SITE ORGANIZATION AND RESOURCES

56. Contractor's representative and supervisory staff

56.1. The Contractor shall at his cost provide and ensure continued effective supervision of the Work with the help of the Contractor's Representative, assisted by team of qualified, experienced and competent engineers, supervisors and adequate staff, to the satisfaction of the Engineer-in-Charge for the entire duration of the Work. The Contractor shall submit his proposed site organization chart for the approval of the Engineer-in-Charge. The Contractor's Representative shall be on the Site at all times as the Work and the Work progresses and shall be responsible for carrying out the Work to the true meaning of the Drawings, Specifications, Conditions of Contract, Schedule of Rates, the other Contract Documents, and instructions and directions of the Field Engineers. The instructions and directions given in writing to the Contractor's Representative or to any of his assistants at the Site by the Engineer-in-Charge shall be deemed to have been given to the Contractor officially. Attention is called to the importance of the Contractor requesting written instruction from the Engineer-in-Charge before undertaking any Work where the Engineer-in-Charge's and/or PMC's direction or instructions are required. Any such Work done in advance of such instructions will be liable to be removed at the Contractor's expense and will not be paid for unless specifically approved in writing by the Engineer-in-Charge, as the case may be. All key staff employed at the Site by the Contractor shall be considered essential to the performance of the Work and the Work Co-ordination Services, and all key staff shall be subject to the approval of the Engineer-in-Charge. However such approval shall not relieve the Contractor of any of his Contractual obligations. No staff including the resident engineer and other technical supervisory staff shall be removed or transferred from the Work without the prior written permission of the Engineer-in-Charge. The Engineer-in-Charge shall, however, have the authority to order the removal from Site of any undesirable personnel. If key staff becomes unavailable for assignment to the Work or the Work Co-ordination Services for reasons beyond the Contractor's control, the Contractor shall immediately notify the Engineer-in-Charge to evaluate the impact on the Work. Prior to substitution or addition of any key staff, the Contractor shall obtain the Engineer-in-Charge's written consent as to the acceptability of replacements or additions to such personnel. The Contractor shall at all times be fully responsible for the acts, omissions, defaults and neglect of all of his representatives, agents, servants, workmen and suppliers and those of his Sub-Contractors.

57. Man -power and plant and machinery

57.1. The Contractor shall at his own cost provide and install all equipment, materials, plant/machines. Provision of Passenger Lift, Batching Plant, Concrete Pumps, Cranes, and Material Hoists each of adequate capacity, will be required in case of bulk concreting and fast construction. Other equipments like concrete mixers (weigh batchers in case of design mixes), ladders, and scaffolding etc, necessary for the execution of the Work in conformity with the Contract Documents and to the satisfaction of the Engineer-in-Charge will also be provided by the contractor at his own cost in adequate quantity. All machines, tools, trucks, formwork material, man-power and everything else necessary for the proper and satisfactory execution and completion of the Work in accordance with the Contract Documents shall be provided by the Contractor at his own cost. The pre-qualification approval of the list of equipments however shall not relieve the Contractor of any of his responsibilities, obligations and liabilities under the Contract. The Contractor shall augment his manpower, plant and machinery without extra cost to the PMC/Client Department whenever required or so directed by the Engineer-in-Charge in order to conform to the approved construction programme for the achievement of milestones and Virtual Completion. The batching plant, hot mix plant WMM plant and Concrete batch mix plant shall be computerised (Microprocessor based) with printing facility so as to keep the printed out-put for each batch of concrete mix and for each component (stone aggregates, sand, cement, fly ash, water, plasticiser & any other concrete admixture) for each batch of design mix concrete for record purpose. The plants shall also be equipped with antipollution device and mechanisms.

58. Contractor store, site offices and other facilities

58.1. It is agreed that the Contractor has inspected the site and has made his own assessment towards the availability of space at site for his stores, yards, offices, placement of batching plant, steel & shuttering yards, cranes, material hoists and other facilities. A mutually determined area within the constraints of the Site will be allowed to the Contractor free of cost for the purpose of storing his tools, plant, materials, Site office, cement godown, canteen, plant & machinery etc. In case contractor is not able to accommodate his facilities within the site, or in the opinion of the Engineer-in-Charge contractor's facilities are to be removed or relocated in the interest of the progress of work (contractors and / or any other agencies / vendors) the contractor shall make his own arrangements elsewhere outside the site at his own cost for the same. Water tank for the purpose of construction, Site offices, toilets, workshops and storage sheds etc. shall be built by the Contractor at the Contractor's cost. Water tank/s constructed for the purpose of construction should be of such dimensions as to provide storage for at least two days consumption. Site offices shall be of such dimensions to accommodate the Contractor's own office. A separate sanitary facility shall be provided and maintained for, Engineers and workers. The same shall be cleared or removed after construction period. The Contractor shall remove all the temporary construction constructed by him at the Site for the purpose of completing the Work after the Work is completed. Costs of all such facilities including construction & removal shall be borne by the Contractor. Construction of labour hutments will not be allowed inside the Site. The Contractor shall at his own cost make all arrangements for space, lodging, transportation etc. for the labour.

59. Security

59.1. The Contractor shall at his cost provide at all times adequate number of watchmen to guard the Site, materials and equipment, to the satisfaction of the Engineer-in-Charge. The Contractor shall at all times be fully responsible for the security of all materials and equipment on the Site, whether owned by the PMC/Client Department, Contractor's own or those of any Sub-Contractor. PMC/Client Department/ Engineer shall not be responsible for any loss due to theft, fire, accident or any other reasons, whatsoever.

60. Telephone / Communication/Other services

60.1. The contractor shall make his own arrangement for the telephones and communication at site with information to the Engineer-in-Charge.

61. Sanitary Convenience:

61.1. The Contractor shall at his expense provide and erect with prior permission and details to the Engineer-in-Charge all necessary sanitary conveniences including septic tank and soak pits at the Site for the staff and all workmen of his own, his Sub-Contractors, the Engineer and Engineer's Representatives. The sanitary conveniences shall be strategically located around the Site to provide ready access to all site operatives and employees. The Contractor shall maintain such convenience in a clean, hygienic, orderly condition and shall clean, disinfect and deodorize the ground after their removal, and meet all statutory requirements.

62. Scaffolding, staging, guard rails, barricades:

The Contractor shall at his cost provide steel scaffolding, staging, guard rails, barricades and safety barriers around all excavations, openings and at all edges, temporary stairs and other temporary measures required during construction. The supports for the scaffolding, staging guard rails, barricades and safety barriers and temporary stairs shall be strong, adequate for the particular situations, tied together with horizontal pieces and braced properly. The temporary access to the various parts of the building under construction shall be rigid and strong enough to avoid any chance of mishaps. The entire scaffolding arrangement together with the staging, guard rails, barricades and safety barriers, and temporary stairs shall be to the approval of the Engineer-in-Charge which approval however shall not relieve the Contractor of any of his responsibilities, obligations and liabilities for safety and for timely completion of the Work. The use of wooden scaffolding on the Site is strictly forbidden.

63. Temporary Roads:

The Contractor shall at his cost construct and maintain temporary roads/access ways to suit Site requirements at locations mutually agreed with the Engineer. Such roads/access ways will also be used by other Contractors/vendors/Officials working at the Site.

64. Safety Equipment & Personnel:

64.1. The Contractor shall provide sufficient helmets, safety boots/shoes, nets and protective clothing for use by the Work Management Team, Engineer, Engineer's Representative, contractor's own staff and staff of his sub-contractors. The Contractor shall make available at all times when work is being undertaken, a vehicle suitable for the emergency evacuation of personnel from the site to a hospital staffed and equipped to receive injured personnel.

65. Temporary Lighting:

65.1. The Contractor shall make his own arrangement in respect of the provision of adequate lighting at all places where adequate visibility is not there or at night works and also provide general lighting of site as a whole in a proper safe and satisfactory manner.

66. Protection of Environment:

66.1. The Contractor understands that the Site is free from pollutants at the time of access to the Site and commencement of the Work. The Contractor shall comply with all applicable environmental laws and regulations and shall ensure that the Site is and remains free from pollutants at the end of the Work. The Contractor shall ensure inter-alia, that neither the soil nor the ground water is polluted or contaminated by fuels or lubricants emitted by machinery operated on the Site or by other dangerous or poisonous substances which are or are deemed to be hazardous to the environment. Notwithstanding the above, the Contractor shall comply with all the directions and decisions of the Engineer in this regard.

67. First Aid Facilities:

67.1. The Contractor shall provide adequate first aid facilities at site.

68. Labour regulations:

68.1. The Contractor shall be wholly and solely responsible for full compliance with the provisions under all labour laws and /or regulations such as Payment of Wages Act 1948, Employees Liability Act 1938, Workmen's Compensation Act-1923, Employees State Insurance Act-1948, Employees Provident Fund Act-1952, Industrial Disputes Act-1947, the Maternity Benefit Act-1961, the Contract Labour (Regulation and Abolition) Act-1970 and the Factories Act-1948 or any modifications thereof or any other law relating thereto and rules there under introduced from time to time. The Contractor shall assume liability and shall indemnify the PMC/Client Department and Engineer-in-Charge from every expense, liability or payment by reason of the application of any labour law, act, rules or regulations existing or to be introduced at a future date during the term of the Contract. Insurance cover towards the above shall be effected by the Contractor as called for in Clause 12. In general, in respect of all labour directly or indirectly employed in the Work for the performance of Contractor's part of the Contract, the Contractor shall comply with all the rules framed by the Government authorities concerned from time to time for protection of the health and welfare of the workers. The Contractor shall at his own cost obtain a valid licence for himself and the PMC/Client Department under the Contract Labour (R & A) Act 1970 and the Contract labour (Regulation and Abolition) Central Rules 1971 and under any other applicable rules before the commencement of the Work and continue to have a valid licences until the completion of the Work.

68.2. Payment of wages: The Contractor shall pay to labour employed by him either directly or through Sub-Contractors wages not less than fair wages as defined in the relevant Central / Local Labour Regulations or as per the provisions of the Contract Labour (Regulation and Abolition) Act 1970 and the Contract Labour Regulation and Abolition of Central Rules 1971, wherever applicable. He shall also abide by the minimum wages and other regulations applicable to the labour engaged in the Work, as laid down by the concerned Central / local authorities (State, District or other local Authorities). In case the contractor fails to pay fare wages as required by the authorities then the PMC/Client Department/ Engineer-in-Charge shall be entitled to do so and receives such amounts including associated cost incurred by them in doing so from the contractor.

68.3. Model Rules: The Contractor shall at his own expense comply with or cause to be complied with, Model Rules for labour welfare framed by Government or other local bodies from time to time for the protection of health and for making sanitary arrangements, Malaria control, etc. for workers employed directly or indirectly on the Work and in the workers hutment area. In case the Contractor fails to make arrangements as aforesaid, the PMC/Client Department shall be entitled to do so and recover the cost thereof from the Contractor.

- 68.4. Safety Codes: In respect of all labour, directly or indirectly employed on the Work for the performance and execution of the Contractor's Work under the Contract, the Contractor shall at his own expense arrange for all the safety provisions as listed in (i) Safety codes of Central Public Works Department and Bureau of Indian Standards.(ii) The Electricity Act, (iii) The Mines Act, and Regulations, (iv) Regulations of employment & conditions of service Act 1996, Rules and Orders made there under and such other acts as applicable. Precautions as stated in the safety clauses are of minimum necessity and shall not preclude the Contractor taking additional safety precautions as may be warranted for the particular type of work or situations. Also mere observance of these precautions shall not absolve the Contractor of his liability in case of loss or damage to property or injury to any person including but not limited to the Contractor's labour, the Employer's Consultants, Employer's Representatives, Client's representatives and Engineer-in-Charge's representatives or any member of the public or resulting in the death of any of these. Protective gear such as safety helmets, boots, belts, gloves, spectacles, nets, fire extinguishers etc. shall be provided by the Contractor at his own cost to all his manpower at the Site. The Contractor shall impose such requirements on all Sub-Contractors and Vendors also. It shall be the responsibility of the Contractor to ensure that such protective gear is worn at all times by all personnel working at the Site during the term of the Work. The Employer, Engineer, and Engineer's Representative shall each have the right to stop any person not wearing such protective gear from working on the Site.
- 68.5. In case the Contractor fails to make arrangements and provide necessary facilities as aforesaid, the Engineer-in-Charge shall be entitled (but not obliged) to do so and recover the costs thereof from the Contractor. The decision of the Engineer-in-Charge in this regard shall be final and binding on the Contractor.

69. Safety/Site Conditions:

- 69.1. The Contractor shall take full responsibility for the adequacy, stability and safety of all Site operations and ensure that the methods of carrying out the Work and the Work by the Contractor including his workmen, employees, Sub-Contractors and Vendors meet all the necessary safety standards and requirements. In order to fulfil this obligation the Contractor shall appoint a permanent, full time and suitably qualified safety officer for the Site, who shall be responsible for incorporation, implementation and enforcement of all safety measures and requirements for maintaining safe working conditions, safety of manpower and equipment, general safety and security of Site as per the various safety codes and stipulations mentioned in contract documents. The Contractor shall provide Id-Cards (Identity Cards) to each of his worker with designated number & colour only of the card as directed by the Engineer-in-Charge.
- 69.2. The Contractor has full responsibility for maintaining the Site in good and clean condition and removing all trash and debris on a daily basis to the satisfaction of the Engineer. The Contractor is responsible for providing adequate sanitary facilities and maintaining them in a clean and healthy condition. If the Contractor fails to comply with the above the Engineer-in-Charge will have the authority to get the same cleaned by an external agency and debit the expenses incurred on the same to the Contractor's account; but without being under any legal obligation to do so.
- 69.3. If, by reason of any accident, or failure, or other event occurring to, in, or in connection with the Work, or any part thereof, either during the execution of the Work, or during the Defects Liability Period, any remedial or other work is, in the opinion of Client Departments Representative or the Engineer-in-Charge urgently necessary for the implementation of the safety programme of the Work by the Contractor and the Contractor is unable or unwilling at once to do such work, the Engineer-in-Charge shall be entitled to employ and pay other persons to carry out such work as the Engineer-in-

Charge may consider necessary. If the work or repair so done by the Engineer-in-Charge is work which, in the opinion of the Engineer-in-Charge, the Contractor is liable to do at its own cost, then all costs consequent thereon or incidental thereto shall be recoverable from the Contractor and may be deducted by the Engineer-in-Charge from any of the Performance Security Deposit and any moneys due or to become due to the Contractor and the Engineer-in-Charge shall notify the Contractor accordingly, provided that the Engineer-in-Charge shall, as soon after the occurrence of any such emergency as may be reasonably practicable, notify the Contractor thereof. The Contractor shall ensure that all operations by the Contractor, his workmen, employees, Sub-Contractors to complete the Work and the remedying of any defects therein shall, so far as compliance with the requirements of this Agreement permit, be carried on so as not to interfere unnecessarily or improperly with:

- a. The convenience of the public, or
- b. The access to, use and occupation of public or private roads, railways and footpaths to or of properties whether in the possession of Client Department/Engineer-in-Charge or of any other person.
- c. The Employers /Engineer-in-Charge's operation and utilization of the facility at the Site; and
- d. The Work of Vendors/other contractors.

69.4. If any hazardous or obnoxious materials (as defined by Indian law) are specified for use or are being used by Sub-Contractors or Vendors, the Contractor shall take necessary clearances from concerned departments and keep record of such material and forthwith give written notice to the Engineer-in-Charge and shall ensure that the Sub-Contractors and Vendors, as applicable, use, store and dispose of such hazardous or obnoxious materials strictly in accordance with all applicable laws.

69.5. Additional Safety Regulations: The Contractor shall continuously maintain adequate protection for the Work against fire and other hazards and shall protect the Department/Client /Engineer's property from damage or loss during the performance of this Contract. The Contractor also shall adequately protect property adjacent to the Work. The Contractor shall take all necessary precautions for the safety of its employees, Subcontractors and the Vendors performing the Work and later phases of the Work and shall comply with all applicable safety laws and regulations to prevent accidents or injury to persons on, about, or adjacent to the Site. The Contractor shall be responsible for co-ordinating a safe working programme with the Field Engineers. Such a programme shall include, and the Contractor shall be responsible for maintaining, the following safe working conditions and practices:

- a. All combustible material, food matter, garbage, scrap, and other debris generated during the performance of the Work shall be collected and removed from the Site on daily basis. Arrangements for scrap disposal should be discussed with Field Engineers.
- b. An adequate number and type of fire extinguishers and sand buckets shall be provided at the Site for fire control and shall be kept/maintained in satisfactory and effective working condition, at all times.
- c. The Contractor and its employees, labourers and subcontractors shall strictly obey all "No Smoking" restrictions.
- d. The Contractor shall not operate or use or manipulate utilities already established at the Site without the Engineer-in-Charge's prior written approval.

69.6. Safety with regard to site and housekeeping:- The contractor shall depute a dedicated team of adequate number of worker under the responsibility of the Safety In-charge for carrying out the safety and housekeeping work at site on daily basis. Following shall be ensured by the Contractor and his safety & housekeeping team:

- a. The use of intoxicants or unlawful drugs at the Site, in any degree, shall be strictly prohibited. The Contractor shall rigorously enforce this regulation.
- b. When overhead work is in progress in or around an occupied area, signs to denote such work prominently displaying "Overhead Work" shall be used and a barricade shall protect the area. Safety nets and appropriate catchments provisions shall be provided at suitable levels so as not to allow any material to fall on the ground.
- c. Dusty work, such as concrete breaking or demolition, in or near occupied areas, shall proceed only after wetting down the area and taking steps necessary to prevent dust from penetrating occupied areas and creating a nuisance.
- d. Care shall be taken not to block any door, passageway, and safety exit, fire fighting equipment, or safety equipment with materials or equipment.
- e. Materials must be piled, stacked, or stored in a neat and orderly manner. All stacking in the site, whether inside or outside a building, shall be parallel to or at right angles to the building line or fence. The stacking of materials shall be organised on daily basis.
- f. When noisy operations of a prolonged nature are necessary in or near an occupied area, arrangements must be made with the Engineer-in-Charge for scheduling to minimize any nuisance in the occupied area.
- g. All critical and dangerous locations / areas at site shall be marked with caution signs, indications and directions in the form of well designed and uniform signage, the design of signage shall be approved by the Engineer-in-Charge.

69.7. If the Field Engineer notifies the Contractor of non-compliance with all or any of the foregoing regulations, the Contractor shall immediately, if so directed, or in any event not more than eighteen (18) hours after receipt of such notice, make all reasonable efforts to correct such non-compliance. If the Contractor fails to do so, the Engineer-in-Charge may suspend all or any part of the Work. When the Contractor has undertaken satisfactory corrective action, Engineer-in-Charge shall lift the suspension of the Work. The Contractor shall not claim any extension of time to complete the Work or additional fees due to any such work suspension.

70. Child Labour:

70.1. The Contractor shall not employ any labour less than 18 (eighteen) years of age on the job. If female labour is engaged, the Contractor shall make necessary provisions at his own expense for safeguarding and care of their children and keeping them clear of the Site. No children shall be permitted at the Site.

71. Contribution towards workers/employee benefits, funds etc

71.1. The Contractor shall include in the Contract Price all expenses necessary to meet his obligations for making contributions toward employee benefits funds (Such as provident fund, Employees State Insurance benefits, ESI, old age pension and/or any other benefits/compensation legally payable) in compliance with all the statutory regulations and requirements. All records in this connection shall be properly maintained by the Contractor and produced for scrutiny by the concerned authorities and the Engineer-in-Charge and the Employer whenever called for.

71.2. Employees State Insurance Scheme (ESI): The Contractor shall be liable to pay his contribution and Employees contribution to the State Insurance Scheme in respect of all labour employed by him or for the execution of the contract in accordance with the provision of "The Employees State Insurance Act, 1948" as amended from time to time.

71.3. Employees Provident Fund (EPF): The Contractor shall obtain prescribed recommendations from the Regional Provident Funds Commissioner under the Employees Provident Fund and Miscellaneous Provisions Act, 1952 and shall cause

provident fund contribution from all eligible employees and Contractor's contribution to be deposited regularly with the prescribed authority and in token of which shall submit every month necessary receipts/ documentary evidence as may be required by the Engineer-in-Charge. The contractor shall also provide its Provident Fund registration number/ certificate to Engineer-in-Charge. In case the contractor fails to comply with above provisions as required by the authorities then the Engineer-in-Charge shall be entitled to do so and recover such amounts including the associated costs incurred by them in doing so, from the contractor. The Contractor must fully satisfy himself as to these points and allow coverage for the same in the rates while giving his tender. Nothing extra shall be paid on these accounts.

72. Setting out and site surveys

- 72.1. The Contractor shall establish, maintain and assume responsibility for all bench marks and grid lines, and all other levels, lines, dimensions and grades that are necessary for the execution of the Work, in conformity with the Contract Documents. The Contractor shall establish his relation to the permanent benchmarks and boundary lines established at the Site. The Contractor shall verify and co-relate all the survey data available at the Site before commencing the Work and shall immediately report in writing any errors or inconsistencies to the Field Engineer. Commencement of Work by the Contractor shall be regarded as his acceptance of the correctness of all survey and setting out data available at the Site and no claims shall be entertained or allowed in respect of any errors or discrepancies found at a later date. If at any time error in this regard appears during his progress of the Work, the Contractor shall at his own expense rectify such error to the satisfaction of the Engineer. The approval by the Engineer of the setting out by the Contractor shall not relieve the Contractor from any of his responsibilities, obligations, and liabilities under the Contract.
- 72.2. The Contractor shall be entirely and exclusively responsible for the horizontal, vertical and other alignment for all levels and dimensions and for the correctness of every part of the Work, and he shall rectify effectively any errors or imperfections therein. All such rectifications shall be carried out by the Contractor at his own cost and to the instructions and satisfaction of the Engineer-in-Charge
- 72.3. The Contractor shall employ qualified surveyors to carry out all the surveys and setting out works.

73. Drawings, specifications, interpretations etc

- 73.1. The drawings included/available with the tender are to be used for general guidance only. These drawings are broadly indicative of the work to be carried out. These drawings are not the "Construction Drawings and details indicated there in are for guidance only and are liable to be modified by the Engineer-in-Charge during course of actual construction. No claim what so ever shall be admissible on account of changes that may be introduced later by the Engineer-in-Charge.
- 73.2. In general, the Drawings shall indicate the dimensions, positions and type of construction, the Specifications shall stipulate the quality and the methods and performance criteria, and the Schedule of Rates shall indicate the rates for each item of work for evaluating change orders. However, the above Contract Documents being complementary, what is called for by any one shall be binding as if called for by all. Wherever there is a discrepancy between drawings and specifications, the drawings shall be followed. In interpreting the specifications, the following order of decreasing importance shall be followed:

- i. Bill of Quantities
- ii. Technical Specifications
- iii. Drawing
- iv. CPWD /MoRTH/IRC Specifications
- v. Indian Standard Specification of BIS

- 73.3. Matters not contained in the specifications and in case of any ambiguities in written specifications of the contract, the works shall be executed as per relevant Bureau of Indian Standards codes, Central Public Works Department specifications, MoRTH specifications and IRC specifications in the above order of preference. If such codes have not been framed, the decision of the Engineer-in-charge shall be final. Any work indicated on the Drawings and not mentioned in the Specifications or vice versa, shall be deemed as though fully set forth in each. Work not specifically detailed, called for, marked or specified shall be the same as similar parts that are detailed, marked or specified. From time to time during the progress of the Work, the Contractor will be issued with revisions of Drawings and written instructions by the Engineer-in-Charge in connection with and necessary for the proper execution and completion of the Work. All such revisions of Drawings and written instructions shall be part of the Contract Documents and the Contractor shall be bound to carry out the work that is shown and detailed on all such Drawings and shall be bound to follow and comply with all such instructions.
- 73.4. It shall be the responsibility of the Contractor to ascertain and ensure that all the Work is carried out in accordance with the latest revisions of the Drawings issued to him. Should the Contractor fail to do this, all the rectifications and remedial work that may be required to conform to the latest revisions of the Drawings shall be at the Contractor's expense.
- 73.5. Wherever it is mentioned in the Conditions of Contract, Specifications, and other Contract Documents that the Contractor shall perform certain work or provide certain facilities, it is understood that the Contractor shall do so at his own cost, unless otherwise provided in the Documents.
- 73.6. No deviations shall be made by the Contractor, in the execution of the Work from the Drawings, Specifications, and other Contract Documents. Only the Engineer-in-Charge shall issue interpretations and clarifications.
- 73.7. The Contractor shall immediately in writing bring any errors or inconsistencies in the Drawings and Specifications to the attention of the Field Engineer for interpretation or correction before proceeding with the affected portion of the Work, and no claims or losses alleged to have been caused by such discrepancies shall be entertained or allowed at any stage. Local conditions, which may affect the Work, shall likewise be brought to the Field Engineer's attention at once. If at any time it is discovered that work, which has been done or is being done is not in accordance with the approved Drawings and Specifications, the Contractor shall correct the work immediately. Correction of such work shall be at the expense of the Contractor and shall not form a basis for any claims for payment or extension of time. The Contractor shall carry out all the rectification work only after obtaining approval for the same from the Engineer-in-Charge.
- 73.8. No scaling of any Drawing shall be done to obtain the dimensions. Figured dimensions on the Drawings shall be used for carrying out the Work. Drawings with large-scale details shall take precedence over small scale Drawings. Where any Drawings and details have not been provided but are necessary for the execution of the Work, it shall be the responsibility of the Contractor to seek these drawings and details in writing from the Engineer-in-Charge at least four weeks prior to the latest date by which the Contractor needs these drawings and details to suit the programmed execution of the

Work. No extension of time shall be allowed for any delays caused due to the Contractor's failure to seek such details.

73.9. Drawings, Schedule of Rates, Specifications, and other Contract Documents, and all copies thereof furnished by the Engineer-in-Charge shall become the Employer's property. They shall not be used on any other work and shall be returned to the Employer at his request or at the completion of the Contract.

74. Overtime work

74.1. If it is necessary for the Contractor or any Sub-Contractor to work on other than working days or outside the normal working hours in order to keep up to the time schedule and meet the Construction Programme, the Contractor shall obtain the prior approval of the Engineer-in-Charge in writing, which approval shall not be unreasonably withheld. The additional cost of wages and any other costs incurred as a result of overtime or any shift work (except supervision expenses incurred by the Employer) shall be borne by the Contractor.

74.2. Where work is being carried out in or around an operating plant / office or occupied building /premises and is liable to cause disturbance or interruption in working of the Plant / Office or inconvenience to the occupants of the premises, the Contractor shall work only at specified places and times as mutually arranged between the Contractor and the Field Engineer so as not to cause any disturbance. Due to this the Contractor may be required to work during off-hours, Sundays and holidays. The Contractor shall not be entitled for any extra payment for doing work in the manner described above.

75. Materials, workmanship, storage, inspections etc

75.1. Employer Supplied Material

- a. The Employer will not supply any material unless otherwise specified in the contract. Sole responsibility rests with the contractor for procurement of all other materials required for completion of work within the stipulated time.
- b. Materials specified as to be issued by the PMC/Client Department , if any, will be supplied to the Contractor by the PMC/Client Department from his stores or the dealer or the dealer's warehouse or railway siding or from any other specified place.
- c. It shall be the responsibility of the contractor to take delivery of the materials and arrange for its loading, transport and unloading at the site of work and to keep the materials under safe custody at the site at his own cost. The materials shall be issued during working hours only.
- d. The Contractor shall bear all incidental charges for the storage and safe custody of materials as directed by the Engineer-in-Charge, at site after these have been issued to him.
- e. The materials shall be issued in standard sizes as obtained from the manufacturers.
- f. It shall be the duty of the contractor to inspect the materials supplied to him at the time of taking delivery and satisfy himself that they are in good condition. After the materials have been delivered, it shall be the responsibility of the Contractor to keep them in good condition and if the materials are damaged or lost, at any time, they shall be repaired and/or replaced by the contractor at his own cost, according to the directions of the Engineer-in-Charge.

- g. The PMC/Client shall not be liable for delay in supply or non-supply of any materials, if any, which he has undertaken to supply where such failure or delay is due to natural calamities, transport and procurement difficulties and any circumstances beyond the control of the Employer. In no case, shall the Contractor be entitled to claim any compensation or loss suffered by him on this account.
- h. It shall be the responsibility of the Contractor to arrange in time all the materials required for the works. If, however, in the opinion of the Engineer-in-Charge / Employer, the execution of the work is likely to be delayed due to the Contractor's inability to make arrangements for supply of materials which normally he has to arrange for, the Engineer-in-Charge / Employer shall have the right, at his own discretion to arrange for issue of such materials from the market or elsewhere and the Contractor will be bound to take such materials at the rate decided by the Employer. This however, does not in any way absolve the Contractor from responsibility of making arrangements for the supply of such material in part or full, should such a situation occur nor shall this constitute a reason for the delay in the execution of the work.
- i. The Contractor shall, if desired by the Engineer-in-Charge / Employer, be required to execute an indemnity bond in the prescribed form for safe custody and accounting of all materials issued by the Employer.
- j. A day to day account of the materials issued by the Employer shall be maintained by the Contractor, indicating the daily receipt, consumption and balance in hand, in a manner prescribed by the Engineer-in-Charge.
- k. The Contractor shall see that only the required quantities of materials are issued. The contractor shall not be entitled to cartage and incidental charges for returning the surplus materials, if any, to a place as directed by the Engineer in charge.
- l. Materials supplied by the Employer, if any, shall not be used for any other purpose or work other than that issued for.

75.2. Contractor Supplied material

- a. All the materials including reinforcement steel, cement, bitumen, aggregate etc shall be procured by the contractor. Quoted rate to include labour, basic cost of material, cost of accessories, taxes, payment to suppliers, transportation, handling, storage, safety, wastage, accounting and reconciliation and to provide Form -C & 38 and any other documents/formalities for purchase of materials, cost of electricity, water, WCT, VAT and Contractor's overheads and profits etc.
- b. In case the Contractor fails / refuses to procure and provide any material, the Engineer-in-Charge in the interest of the work may resort to procure and provide such materials at the risk and cost of the Contractor. Under such circumstances an extra procurement charge @ 15% of the respective item rates shall be imposed on the Contractor and recovered from his bills / any outstanding payments.
- c. The materials shall be fully accounted for by the Contractor as required hereinafter. In accounting for the materials with allowances to cover all wastages and losses that may have been incurred in the process of handling, storing, cutting, fabrication, fixing and installing. The contractor shall submit statement of account and reconciliation of material lying in Contractor's stores along with each Running Account Bill and consolidated statement of reconciliation along with Final Bill.

- d. The Contractor shall, at all times when requested, satisfy the Engineer-in-Charge by the production of records or books or submissions of returns that the materials are being used for the purpose for which they are procured and the Contractor shall at all times keep the records updated to enable the Engineer-in-Charge to apply such checks as he may desire to impose. The Contractor shall, at all times, permit the Engineer-in-Charge to inspect his godown. The Contractor shall not, without prior written permission of the Engineer-in-Charge, utilise or dispose of the materials for any purpose other than intended in the Contract.

75.3. Materials and workmanship:

- a. The Contractor shall be responsible for the establishment of a full and comprehensive quality control system for the Work. The system shall include, but not be limited to, the means of controlling the testing and receipt of materials, the inspection of the Work, the filing and ordering of drawings and correspondence and the duties and responsibilities of staff members.
- b. All materials and equipment to be incorporated in the Work shall be new unless there is specific provision in the contract for reusing old good quality material. The materials, equipment, and workmanship shall be of the best quality of the specified type, in conformity with Contract Documents and the best engineering and construction practices, and to the complete satisfaction of the Engineer-in-Charge. This requirement shall be strictly enforced at all times and stages of the Work and no request for change whatsoever shall be entertained on the grounds of anything to the contrary being the prevailing practice. The Contractor shall immediately remove from the Work any materials, equipment and/or workmanship which, in the opinion of the Engineer-in-Charge, are defective or unsuitable or not in conformity with the Contract Documents and best engineering and construction practices, and the Contractor shall replace such rejected materials, equipment and/or workmanship with proper, specified, required and approved materials, equipment and/or workmanship, all at his own cost within a period of seven (7) days from the date of issuance of such notice.
- c. The Contractor shall, whenever required to do so by the Engineer-in-Charge, immediately submit satisfactory evidence and necessary test results as to the kind and quality of the materials and equipment.

75.4. Special makes or brands:

- a. Where special makes or brands are called for, they are mentioned as a standard. Others of equivalent quality may be used provided that Engineer-in-Charge considers the substituted materials as being equivalent to the brand specified, and prior approval for the use of such substituted materials is obtained in writing from the Engineer-in-Charge.
- b. Unless substitutions are approved by the Engineer-in-Charge in writing in advance, no deviations from the Specifications and other Contract Documents shall be permitted, the Contractor shall indicate and submit written evidence of those materials or equipment called for in the Specifications and other Contract Documents that are not obtainable for incorporation in the Work within the time limit of the Contract. Failure to indicate this in writing will be deemed sufficient cause for denial of any request for an extension of time and /or additional cost because of such circumstances.
- c. Alternative equivalent brands if suggested by the Contractor during construction may be considered if approved brand is not available in market, provided the

suggested brand fully meets the requirements and is acceptable to the Engineer-in-Charge.

- 75.5. Contractor shall be responsible for providing, at his own cost, proper and adequate security for all the materials and equipment stored at the Site so as to prevent any theft, pilferage etc., and the Contractor shall be responsible and liable for all the matters in connection with such security or the lack thereof. Where, after permission has been sought and obtained from the Engineer-in-Charge, any material or equipment is kept on any portion of the structure, this shall be done in such a manner as to prevent any overloading whatsoever of the structure, to the complete satisfaction of the Engineer-in-Charge. The cost associated with any damage to any portion of the structure in this respect shall be to the account of the Contractor and shall be borne by him. Should delays be caused on account of removal and replacement of any materials or equipment or on account of any lack of security, the Contractor shall not be entitled to any extension of time or increase in the Contract Price. Wherever applicable the storage of materials shall be in accordance with the relevant Indian Standard Specifications. Reinforcement bars shall be stored diameter-wise over raised sleepers and protected from rain in suitable manner as approved by the Engineer-in-Charge. Similarly, structural steel sections shall also be stored in the yard in a proper orderly manner.
- 75.6. Certificates: The Contractor shall furnish, at his own cost, test certificates, calibration certificates for the various materials and equipment as called for by the Engineer-in-Charge. Such test certificates should be for the particular consignment/lot/piece as decided by the Engineer-in-Charge. The details in respect of the test and calibration certificates shall be as decided by the Engineer-in-Charge for the relevant items.

76. Construction programme and Site order book

76.1. Construction Programme:

- 76.1.1. The contractor should furnish an overall construction programme for the approval of the Engineer-in charge before the start of the works. The construction programme shall clearly show all the sequential activities of work required to be carried out from the commencement of the Work up to the Virtual Completion.
- 76.1.2. The construction programme shall be based on the mutually agreed milestones.
- 76.1.3. Every month, or sooner if required by the Engineer-in-Charge, the approved programme charts shall be reviewed in relation to the actual progress of the Work, and shall be updated as necessary. If at any time it appears to the Engineer-in-Charge that the actual progress of the Work does not conform to the approved programme, the Contractor shall produce, at its expense and without reimbursement therefore, a revised programme showing the modifications to the approved programme and the additional input of resources by the Contractor necessary to ensure completion of the Work within the time stipulated for completion.
- 76.1.4. The submission to and approval by the Engineer-in-Charge of such programmes or the furnishing of such particulars shall not relieve the Contractor of any of his responsibilities, obligations and liabilities under the Contract.

76.2. Site Order Book/Work spot Order Book –shall be maintained at the Site as per the provisions contained in the Revised Kerala PWD Manual-2012.

76.3. Site Register:

76.3.1. The Contractor shall maintain a site register that records the name and time of arrival and departure, at Site, of any visitors.

77. Protections of works:

77.1. The Contractor shall take full responsibility for the proper care and protection of the Work from commencement of work until completion and handing over of the Work to the Assistant Engineer at no additional cost. The Contractor shall protect and preserve the Work in every way from any damage, fire or accident, including by providing temporary roofs, boxing or other construction as required by the Engineer. This protection shall be provided for all property on the Site as well as adjacent to the Site. The Contractor shall adequately protect, to the satisfaction of the Engineer-in-Charge, all the items of finishing work to prevent any chipping, cracking, breaking of edges or any damage of any kind whatsoever and to prevent such work from getting marked or stained or dirty. Should the Contractor fail to protect the Work or any part thereof and should any damage be caused to the same, the Contractor shall be responsible for all replacement and rectification, as directed by the Engineer, and all costs and expenses in connection with such replacement and rectification shall be to the account of the Contractor and shall be borne by him.

77.2. The Contractor shall in connection with the Work provide and maintain at his own cost all lights, security guards, fencing and anything else necessary for the protection of the Work and for the safety of the public and everyone associated with the Work, all to the approval and satisfaction of the Engineer-in-Charge.

77.3. All operations necessary for the execution of the Work shall be carried out so as not to interfere with the convenience of the public, or with the traffic, or the access to, use and occupation of public or private roads and footpaths or of properties whether in the possession of the Employer or of any other person. The Contractor shall save harmless and indemnify the Employer & Engineer in respect of all claims, proceedings, damages, costs, charges, and expenses whatsoever arising out of or in relation to any such matters.

78. Cleaning of works and clearing of site:

78.1. The Contractor shall maintain the Site, adjoining areas within 20 meters all around site and all Work thereon in neat, clean and tidy-conditions at all times. The Contractor shall remove all rubbish and debris from the Site and adjoining areas on daily basis and as directed by the Field Engineer. Suitable steel skips shall be provided at strategic locations around the Site to receive waste and packaging materials.

78.2. Just prior to the Virtual Completion of the Work, or whenever so directed by the Engineer, the Contractor shall carry out all the work necessary to ensure that the Site & 20 meter area all around site is clear and the Work are clean in every respect, the surplus materials, debris, sheds and all other temporary structures are removed from the Site, all plant and machinery of the Contractor are removed from site, the areas under floors are cleared of rubbish, the gutters and drains are cleared, the doors and sashes are eased, the locks and fastenings are oiled, all electrical, plumbing and other services are tested and commissioned, the keys are clearly labelled and handed to the Assistant Engineer, so that at the time of Virtual Completion the whole Site and the Work are left fit for immediate occupation and use, to the approval and satisfaction of the Engineer-in-Charge.

78.3. Should the Contractor fail to comply with the cleaning requirements, whether progressively or before completion, or fail to clear the Site and 20 meter area all around

site as directed and required, then the Engineer-in-Charge, after giving due notice in writing to the Contractor, shall have the right to employ other persons or agencies to carry out the cleaning and/or clearing work and all costs incurred on such work shall be recovered from the Contractor and shall be deducted by the Employer / Engineer-in-Charge from any money that may be payable or that may become payable to the Contractor

79. Settlement of disputes

- 79.1. Arbitration shall not be a means of settlement of any dispute or claim out of this contract. All disputes and differences arising out of the contract may be resolved through discussions between the PMC and the Contractor within the purview of the contract agreement. If such discussions are not fruitful, the disputes shall be settled only by the Civil Court in whose jurisdiction the work covered by the contract is situated, or in whose jurisdiction the contract was entered into in case the work extended to the jurisdiction of more than one court.

Part III

SPECIAL CONDITIONS OF CONTRACT

1. General

1.1 The Special Conditions of Contract are an extension of and are to be read in conjunction with the General Conditions of Contract. Should there be any contradictory requirements in the two, the requirement as per the Special Conditions of Contract shall prevail.

2. Reference drawings

2.1 The Contractor shall maintain on site one set of all Drawings issued to him for reference.

3. Completion drawings (As Built) & Measurement books

3.1. On completion of the Work, the Contractor shall submit three (3) complete sets of drawings and marked up prints of "AS BUILT" drawings verified and approved by the Engineer-in-Charge. These drawings shall include and show all the changes / deviations made from the working drawings during the course of construction and also the other details as called for by the Engineer-in-Charge. During the execution of the Works a set of drawings prepared initially shall be retained in the Contractors Site Offices for the exclusive purpose of recording changes made to the Work as the construction proceeds. The drawings shall be prepared on computer through CAD Software and provided to the Engineer-in-Charge as hard and soft copy.

4. Testing of installations:

4.1. All water retaining structures and the basement shall be tested as specified for the waterproof qualities, in the presence of the Engineer-in-Charge or his authorised representative. The Contractor shall also perform all such tests as may be necessary and required by the Engineer-in-Charge to ensure quality of the executed works. The Contractor shall provide all labour, equipment, and materials etc., required for the performance of the tests.

5. Quality assurance and Quality Control

5.1. The Contractor shall establish an effective quality control system at the Site and implement the same through an independent team consisting of qualified and experienced Engineers and technical personnel to enforce quality control on all items of the Work at all stages. Generally the following are to be noted regarding the quality control of the works in this contract.

5.2. Quality control of various items in this Work shall be governed by the provisions of Kerala PWD Quality Control (QC) Manual approved vide GO(Rt) No-1339/2015/PWD dated 10-9-2015 and Kerala PWD Quality Control laboratory Manual approved vide GO(Rt) No-1346/2015/PWD dated 11-9-2015 and subsequent modifications if any.

5.3. The intending bidders are expected to familiarize with the contents of QC manual before participating in the bid.

5.4. Technical audit as envisaged in clause 2406 of the revised PWD Manual-2012 shall be carried out for this Work. The contractor shall extend full cooperation to the agency entrusted with the technical audit.

- 5.5. The contractor shall extend full cooperation to the departmental officers of quality control wing for taking samples, curing and keeping them in safe custody whenever required. The contractor shall issue proper acknowledgement for samples so kept in his safe custody.
- 5.6. The contractor is to mobilise technical personnel who are well versed with quality control tests and other guidelines stipulated in the QC manual.
- 5.7. For Works or works costing more than Rs.200 lakhs, the selected Contractor shall establish site laboratories with required facilities as specified in PWD Laboratory Manual.
- 5.8. The contractor is responsible for ensuring quality of each item of work in this contract.
- 5.9. Being the agency entrusted with execution of the Contract, the primary responsibility for ensuring quality of each item of work in this Contract is vested with the Contractor. Engineer or his Representative shall issue guidelines as and when required for ensuring Quality Control, which the Contractor has to follow.
- 5.10. The Engineer and his Representative shall have the right to direct Contractor to remove materials supplied which do not conform to standards specified.
- 5.11. For works costing more than Rs.200 lakhs, the contractor shall conduct first tier quality control tests for all items of work at the site laboratory as per the procedure stipulated in the PWD Quality Control Manual at his own expense.
- 5.12. The Contractor is bound to carry out rectification works at his own cost, if results obtained during quality control tests either in the first-tier or second-tier do not comply with the standards. He shall also carry out rectification works, if any pointed out during technical audit done after completion of work.
- 5.13. The decision of the Engineer-in-charge regarding compliance of test results and rectification works to be done shall be final and binding on the contractor.
- 5.14. Payment for works which are to be re-done or rectified will be made only after the Engineer-in charge, after inspection, certifies in writing that the rectifications have been done satisfactorily and the results of the tests conducted after the rectification comply with the specified values.
- 5.15. Third party testing shall be done in an independent approved laboratory, if there is dispute due to difference in the test results of first-tier and second-tier testing or if any manipulated results are suspected. In case, certain specific tests cannot be carried out with the facilities available in the Contractor's site laboratory or the Department laboratories, third party testing shall be resorted to.
- 5.16. Engineer in charge shall decide whether third party testing is required to settle a dispute. His decision will be final and binding on the Contractor.
- 5.17. Third party tests, if approved by the Engineer-in charge shall be arranged by the Contractor in an approved laboratory as directed by the Engineer-in-charge. It is desirable that the test shall be done in the presence of the representatives of the Engineer-in charge and the Contractor to eliminate any further disputes. The expenses shall be met by the Contractor. The result obtained in the test shall be final and binding on both the Contractor and the PMC.

- 5.18. Wherever specified, the contractor shall also obtain manufacture's test certificate from the manufacturer/dealer and submit the same before executing the items listed in such certificates. Contractor shall be responsible for the genuineness of the Manufacturer's Test Certificate obtained and submitted by him. He shall record a statement in the Manufacturer's Certificate that "This Certificate for supply of (Name of material with item no in BoQ) has been obtained by me from(Name and address of Manufacturer/Dealer) on (date of receipt of certificate) for the actual materials supplied at site.
- 5.19. The rate quoted by the bidder shall include all expenses for carrying out the first tier quality control tests. Expenses for third party tests as detailed in clause 7.4 of the introduction to QC Manual, if required, shall also be borne by the Contractor.

6. Drilling, cutting etc.

- 6.1. All cutting and drilling of walls or other elements of the building or structure for the proper entry/installation of inserts, boxes, equipment, etc. shall be carried out using electrically operated tools only. Manual drilling, cutting, chiselling, etc. shall be permitted with the written approval of Agreement authority. No structural member shall be cut or chased without the written permission of the Engineer-in-Charge. Cutting and drilling of structural members shall be carried out using vibration free diamond wire sawing and diamond drilling only with prior permission from the Engineer-in-Charge. The costs for procurement and using such equipment are deemed to be included in the Contract and no extra costs will be paid.
- 6.2. Horizontal cutting of walls or other supporting structural elements for laying pipe conduits, water supply lines etc., shall be avoided as far as possible. Conduits shall be laid through lintels or slabs or similar elements without affecting the structural safety. The conduits shall be connected to the required locations though vertical cuts in the walls or the supporting elements.

7. Approval by statutory bodies:

The Client Department shall obtain Building Permit and Occupation Certificate after completion of work from the concerned Local self-Government Institution, if applicable under this Contract. The Contractor shall be responsible for providing required notices to authorities and to obtain and retain with him at his own cost all other approvals from the statutory bodies pertaining to works under this tender and temporary structures to be constructed at site or equipments to be erected, labour, Employee Insurance, Provident Funds, Tax Departments. etc and any other approval required to facilitate performance of Contractor's work under the Contract till completion. Refusal by statutory authorities to issue any certificate or any other approvals due to the Contractor's failure to observe the relevant rules and regulations in connection with the construction in accordance with the sanctioned plans and/or specifications shall render the Contractor liable for damages and in addition, render him liable to obtain such certificates at his cost.

8. Name board and publicity

- 8.1 The contractor is not entitled to do any publicity on account of the Work. Contractor shall not put any hoarding, publish any advertisement, put any banner or circulate any pamphlet or adopt any other publicity methods except with prior written approval of the Engineer-in-Charge. A name board may be made and displayed by the Contractor at his own cost at the Site at some approved place. The drawing of the Name Board shall be got approved from the Engineer-in-Charge.

The contents of the board shall be as follows:-

- c. Name of the Work.
- d. Name of the Client/Department.
- e. Name of Agreement Authority with address
- f. Engineer-in-Charge and Field Engineers with contact details.
- g. Contracting Agency with contact details.
- h. Contract Price, Date of Start and Expected date of Completion

9. Water and Electricity

- 9.1. Contractor shall make his own arrangement for electricity and water for construction purposes. The water used for construction purpose shall be potable and tested once in every 6 (six) months. The source of water shall be approved by the Engineer-in-charge.
- 9.2. The contractor shall arrange the water good for construction and personal use at his own cost and shall be responsible for all further connections, pumps, pipes, storage facilities and all other things necessary to distribute and use services from this distribution point.
- 9.3. The electricity required for Construction Work shall be arranged by the Contractor from the authorities and/ or generators provided at site at his own cost. Contractor shall be responsible for all distribution points as may be required for the Work. The Contractor shall also make arrangement for alternative standby services at his own cost in the form of additional Generators of adequate capacity (day and night) so that there is no delay in progress of Work as per construction schedule submitted by him and approved by the Engineer-in-Charge. Contractor shall ensure adequate capacity of generators to support such load sharing with other vendors.
- 9.4. The Contractor shall prepare schematic distribution diagrams of distribution of electricity and water for construction purposes incorporating all safeties and get them approved by the Engineer-in-Charge; the distribution at site shall be in accordance to the approved schematic. The contractor shall ensure incorporation and strict implementation of all safety parameters, equipments, instruments and directions given by the Engineer from time to time in this regard.
- 9.5. The contractor shall install the temporary distribution lines for water and electricity ensuring that work of other agencies / vendors is not interrupted or hampered. In case during the course of construction these lines foul or interrupt or hamper the work of other agencies / vendors, the contractor shall remove and relocate the service lines and relocate the same at his own cost within the time stipulated by the Engineer-in-Charge.
- 9.6. All statutory Fees, & miscellaneous expenses and costs for electric power and Water connection for construction purposes shall be borne by the Contractor.

10. Price Adjustment (applicable only for works having TOC greater than 18 months)

- 10.1. The formula (e) for adjustment of prices are:

R = Total value of work done during the month. It would include the amount of secured advance granted, if any, during the month, less the amount of secured advance recovered, if any during the month. It will exclude value for works executed under

variations for which price adjustment will be worked separately based on the terms mutually agreed.

10.2. Adjustment for labour component

Price adjustment for increase or decrease in the cost due to labour shall be paid in accordance with the following formula:

$$VL = 0.85 \times PI/100 \times R \times (Li - Lo)/Lo, \text{ where}$$

VL = increase or decrease in the cost of work during the quarter under consideration due to changes in rates for local labour.

Lo = the consumer price index for industrial workers for the State on 28 days preceding the date of opening of Bids as published by Labour Bureau, Ministry of Labour, Government of India.

Li = The consumer price index for industrial workers for the State for the period under consideration as published by Labour Bureau, Ministry of Labour, Government of India.

PI = Percentage of labour component of the work.

10.3. Adjustment for cement component

Price adjustment for increase or decrease in the cost of cement procured by the contractor shall be paid in accordance with the following formula.

$$Vc = 0.85 \times Pc/100 \times R \times (Ci - Co)/Co, \text{ where}$$

Vc = Increase or decrease in the cost of work during the quarter under consideration due to changes in the rates for cement

Co = The all India average wholesale price index for Grey cement for on 28 days preceding the date of opening of Bids as published by the Ministry of Industrial Development, Government of India, New Delhi

Ci = The all India average wholesale price index for Grey cement for the month under consideration as published by Ministry of Industrial Development, Government of India, New Delhi

Pc = Percentage of cement component of the work

10.4. Adjustment of Bitumen component

Price adjustment for increase or decrease in the cost of bitumen shall be paid in accordance with the following formula:

$$Vb = 0.85 \times Pb/100 \times R \times (Bi - Bo)/Bo, \text{ where}$$

Vb = Increase or decrease in the cost of work during the quarter under consideration due to changes in the rate for bitumen.

Bo = The official retail price of bitumen at the IOC depot at nearest centre on the day 28 days prior to date of opening of Bids.

Bi = The average official retail price of bitumen at IOC depot at nearest centre for the 15th day of calendar month under consideration.

Pb = Percentage of bitumen component of the work.

10.5. Adjustment for steel component

Price adjustment for increase or decrease in the cost of steel procured by the Contractor shall be paid in accordance with the following formula:

$V_s = 0.85 \times P_s/100 \times R \times (S_i - S_o)/S_o$, where

V_s = Increase or decrease in the cost of work during the quarter under consideration due to changes in the rates for steel

S_o = The all India wholesale price index for reinforcement steel (Bars and Rods) on 28 days preceding the date of opening of Bids as published by the Ministry of Industrial Development, Government of India, New Delhi

S_i = The all India average wholesale price index for reinforcement steel (Bars and Rods) for the month under consideration as published by Ministry of Industrial Development, New Delhi

P_s = Percentage of steel component of the work

Note: For the application of this clause, index of Bars and Rods has been chosen to represent steel group.

10.6. Adjustment of POL(fuel and lubricant)component

Price adjustment for increase or decrease in cost fuel and lubricant shall be paid in accordance with the following formula:

$V_f = 0.85 \times P_f/100 \times R \times (F_i - F_o)/F_o$, where

V_f = Increase or decrease in the cost of work during the quarter under consideration due to changes in rates for fuel and lubricants.

F_o = The official retail price of High Speed Diesel (HSD) at the existing consumer pumps of IOC at the nearest centre on the day 28 days prior to the date of opening of Bids.

F_i = The official retail price of HSD at the existing consumer pumps of IOC at nearest centre for the 15th day of the calendar month under consideration.

P_f = Percentage of fuel and lubricants component of the work.

Note: For the application of this clause, the price of High Speed Diesel oil has been chosen to represent fuel and lubricants group.

10.7. Adjustment for Plant and Machinery Spares component

Price adjustment for increase or decrease in the cost of plant and machinery spares procured by the Contractor shall be paid in accordance with the following formula:

$V_p = 0.85 \times P_p/100 \times R \times (P_i - P_o)/P_o$, where

V_p = Increase or decrease in the cost of work during the month under consideration due to changes in the rates for plant and machinery spares

Po = The all India wholesale price index for heavy machinery and parts on 28 days preceding the date of opening of Bids as published by the Ministry of Industrial Development, Government of India, New Delhi.

Pi = The all India average wholesale price index for heavy machinery and parts for the month under consideration as published by Ministry of Industrial Development, New Delhi

Pp = Percentage of plant and machinery spares component of the work

Note: For the application of this clause, index of Heavy Machinery and Parts has been chosen to represent the Plant and Machinery Spares group.

10.8. Adjustment of Other materials component

Price adjustment for increase or decrease in cost of local materials other than cement, steel, bitumen and POL procured by the contractor shall be paid in accordance with the following formula:

$V_m = 0.85 \times P_m / 100 \times R \times (M_i - M_o) / M_o$, where

Vm = Increase or decrease in the cost of work during the quarter under consideration due to changes in rates for local materials other than cement, steel, bitumen and POL.

Mo = The all India wholesale price index (all commodities) on 28 days preceding the date of opening of Bids, as published by the Ministry of Industrial Development, Government of India, New Delhi.

Mi = The all India wholesale price index (all commodities) for the month under consideration as published by Ministry of Industrial Development, Government of India, New Delhi.

Pm = Percentage of local material component (other than cement, steel, bitumen and POL) of the work.

The percentages given in the Contract Data will govern the price adjustment for the entire contract.

*[The Tender inviting authority shall fill up the percentages as per the requirement in the Works which are to be decided based on the Work components and type]

11. Protection / preservation of trees:

11.1. Contractor shall take all measures necessary to ensure the protection and preservation of existing trees within / outside the boundary of the site. Contractor shall be responsible of any damage / casualty to the trees happening as a result of his working at site and for any action, claim, penalty or expenses imposed by the forest / any other department. No claim / payment shall be payable to the contractor on this account.

12. Sub-Contracting

- 12.1. No subcontracting shall be done without prior written approval of Agreement Authority. Maximum value of works to be sub-contracted is limited to 25% of Contract value. The value of a sub-contract and Provisional Sums items as and when awarded, should be intimated by the Contractor to the Engineer-in charge and it should also be certified that the cumulative value of the sub-contracts awarded so far is within the aforesaid limit of 25%. A copy of the contract between the Contractor and Sub-Contractor shall be given to the Engineer within 15 days of signing and in any case 7 days before the Sub Contractor starts the Work and thereafter the Contractor shall not carry any modification without the consent in writing of the Engineer. The terms and conditions of sub-contracts and the payments that have to be made to the sub-contractors shall be the sole responsibility of the Contractor. Payments to be made to such sub-contractors will be deemed to have been included in the Contract price. However, for major sub-contracts (each costing over Rs 50 lakhs), it will be obligatory on the part of the Contractor to obtain consent of the Engineer. The Engineer will give his consent after assessing and satisfying himself of the capability, experience and equipment resources of the sub-contractor. In case the Employer intends to withhold his consent, he should inform the Contractor within 15 days to enable him to make alternative arrangements to fulfil his programme.
- 12.2. The Contractor shall provide sufficient superintendence, whether on the site or elsewhere, to ensure that the work to be carried out by a sub-contractor complies with the requirements of the Contract.
- 12.3. The proposed sub-contract terms and conditions shall impose on the sub-contractor such terms of the Contract as are applicable and appropriate to the part of the Works to be sub-contracted, to enable the Contractor to comply with his obligations under the Contract.
- 12.4. Notwithstanding any consent to sub-contract given by the Engineer, if in his opinion it is considered necessary, the Engineer-in-charge shall have full authority to order the removal of any sub-contractor from the Site or off-Site place of manufacture or storage.

13. Specialised Works to be carried out by licensed persons/firms:

- 13.2 Technically competent persons or firms holding valid licenses obtained from competent local authority/ proven experience record shall only carry out any special works and service installations included in the scope of the Work. The list of such special works are available in the Government order No-GO(Ms) No-65/2015//PWD dated 24-7-2015.

14. Contractor's temporary works design

- 14.1. The Contractor shall, prior to commencing the construction of any temporary Works like earth protection works for deep excavations, temporary platforms/formworks for heavy concreting etc , submit a certificate to the Engineer signed by him certifying that the temporary Works have been properly and safely designed and checked to carry the intended load without failure and that the Contractor has checked the effect of the Temporary Works on the Permanent Works and has found this to be satisfactory. The PMC and the Engineer shall not be responsible for any failure of such temporary structures and the Contractor is bound to take care of all expenses related to such failures, its rectification and subsequent remedial measures if any at no extra cost.

15. Deduction towards the cost of Bitumen if supplied by the PMC/Client Department

15.1. The cost of bitumen will be recovered at the rate specified in contract data which is excluding cost of empty drum and empty drum of bitumen used on the work should be returned in good condition. If empty drum is not returned in good condition, the value of empty tar drum will be recovered at the rates specified in contract data as per rules. Also the rate for recovery of excess Bitumen used if any shall be double the issue rate or market rate whichever is more.

16. Contractors Technical Personnel at site

16.1. The contractor shall employ engineering personnel in addition to other supporting staff as detailed below for tenure of the contract for works supervision depending upon the cost of work.

- a) a diploma holder (Civil Engineering) with sufficient practical experience for the proper execution and supervision of works costing from Rs. 5 lakhs to 75 lakhs
- b) one Engineering Graduate(Civil Engineering) and one diploma holder (Civil Engineering) for works costing Rs.75 lakhs up to 150 lakhs and
- c) For works from Rs.150 lakhs to Rs.250 lakhs-
 - i. Works Manager- 1no(Civil Engineering Graduate with minimum 3 yrs experience)
 - ii. Site Engineers- 2 nos(one Civil Engineering graduate and one civil diploma holder with minimum 1 year experience)
- d) For works from Rs.250 lakhs to Rs.500 lakhs-
 - I. Works Manager- 1no(Civil Engineering Graduate with minimum 5 yrs experience)
 - II. Site Engineers- 3 nos (one Civil Engineering graduate and two civil diploma holder with minimum 2 year experience)

16.2. If the Contractor fails to employ the required engineering personnel at site as per the above, the Engineer-in charge shall impose a penalty for non-engaging the required personnel at site at the appropriate daily wages rates published by the Government (Finance Department - Enhancement of remuneration of daily wage personnel and persons on contract appointment) prevailing at the time of such non engagement on a per day basis. This amount shall be deducted from any moneys due to the contractor by way of this contract.

17. Contractors Equipments at site

17.1. The contractor shall own/hire/deploy the required tools and plants as specified in the Contract data for the satisfactory execution of the work.

18. Special Conditions for KVAT as per the Kerala Finance Act 2008

18.1. In case of Civil works awarded by Government of Kerala deduction towards KVAT at the prevailing rates(as provided in the Contract Data) will be done on the gross amount of bill payable for the bidders every time. The VAT amount will be retained by the Engineer-in charge when the bill for the work is passed for payment and the amount so retained shall be credited to the sales Tax Department. Necessary certificates in this regard shall be issued to the Contractor in due course.

19. Special condition towards contribution of Kerala Construction Workers Welfare Fund Board.

19.1. Deduction towards the Kerala Construction Workers Welfare Fund

Board contribution will be made at the prevailing rate(as provided in the Contract Data) from any bill amount which includes cost of departmental materials and hire charges of departmental tools and plants . This amount shall be remitted to K.C.W.W.F. by the Engineer-in charge within 15 days of the payment to the Bidder. Necessary certificates in this regard shall be issued to the Contractor in due course.

20. Advance Payments

20.1. Mobilisation Advance

20.1.1. This clause shall be applicable only when so provided in 'Contract Data'.

20.1.2. Mobilization advance, shall not exceed 10% of the Contract Price may be given, if applicable and requested by the contractor in writing within one month of the order to commence the work. Such advance shall be in two or more installments as provided in the contract data. The first installment of such advance shall be released by the Engineer-in-charge to the contractor on a request made by the contractor to the Engineer in- Charge in this behalf. The second and subsequent installments shall be released by the Engineer- in-Charge only after the contractor furnishes a proof of the satisfactory utilization of the earlier installment to the entire satisfaction of the Engineer-in-Charge.

20.1.3. Before any installment of advance is released, the contractor shall produce an unconditional Bank Guarantee from a Nationalised or Scheduled Bank for the amount equal to the amount of advance and valid for the contract period. This Bank Guarantee shall be kept renewed from time to time to cover the balance amount and likely period of complete recovery.

20.1.4. Mobilisation advance, if paid, shall be deducted from the next immediate interim payment at the rate of 25% of the amounts of all Interim Payment Certificates until such time as the advance has been repaid, always provided that the advance shall be completely repaid before 80% completion of work.

20.2. Secured Advance for non-perishable materials

20.2.1. This clause shall be applicable only for the items so provided in 'Contract Data'.

20.2.2. The contractor, on signing an indenture in the form to be specified by the Engineer-in- Charge, shall be entitled to be paid during the progress of the execution of the work up to 75% of the assessed value of any materials which are

in the opinion of the Engineer-in- Charge non-perishable, non-fragile and non-combustible and are in accordance with the contract conditions and which have been brought on the site in connection therewith and are adequately stored and/or protected against damage by weather or other causes but which have not at the time of advance been incorporated in the works. When materials on account of which an advance has been made under this sub-clause are incorporated in the work, the amount of such advance shall be recovered/ deducted from the next payment made under any of the clause or clauses of this contract.

20.2.3. Such Secured Advance shall also be payable on other items of perishable nature, fragile and combustible with the approval of the Engineer-in-Charge provided the contractor provides a comprehensive insurance cover for the full cost of such materials. The decision of the Engineer- in-Charge shall be final and binding on the contractor in this matter. No secured advance, shall however, be paid on high-risk materials such as ordinary glass, sand, petrol, diesel etc.

20.2.4. Secured advance, if paid, shall be recovered from each succeeding interim payment to the extent materials have been incorporated into the Works.

20.3. All advance payments shall be completely recovered before completion of 80% cost of work.

21. Electrical works : The work shall be carried out by a contractor holding valid licence issued by the State Government/Competent Authority for carrying out installation work of all voltage classes involved, under direct supervision of the persons holding valid certificates issued or recognized by the state government/competent authority.

22. The work should be carried out in truly professional manner, neatly finished with proper line, level and plumb. Cleanliness and finishing of the job is of utmost importance. Hence the job should be done most carefully with best workmanship. For all finishing jobs samples should be approved from the Purchaser/Project Management Consultant before completely executing the work.

Part IV

CONTRACT DATA

Sl. No	Item	Clause reference	Data
1	Identification No. of the Contract	NIT	HLL/CHO/PROJ/EXT/SVO/NAGAROR/2018-19 Dated: 21-12-2018
2	Name of Work	NIT	Construction of SMART village office at Nagaroor in Thiruvananthapuram
3	Employer	GCC - 1.1	HLL Lifecare Ltd. (Project Management Consultant)
4	Tender Inviting Authority	GCC - 1.2	HLL Lifecare Ltd. (Project Management Consultant)
5	Name of Client/Department	GCC - 1.3	The District Collector, Thiruvananthapuram
7	Estimated Probable Amount of contract		Rs.38 Lakhs
8	Source of Fund	ITB - 1.2	As per A.S No.A.14E 123827/2018 dated 21.08.2018 from District Collectorate, Thiruvananthapuram
9	Location of Work	NIT	Nagaroor, Thiruvananthapuram
10	Type of Work(brief description about the nature of work)	NIT	Civil Construction works, Electrical Works, Workstation and other Furniture Works.
11	Time of completion of work (in Days)	GCC - 1.15, 14	100 Days
12	Work Milestones	GCC - 15, 43, 76	As per clause/s
13	Eligibility criteria for Pre-Qualification	ITB -1.3.1	As per clause/s
15	Bid submission start date	NIT	04-01-2019
16	Last date and time for bid submission	NIT	07-01-2019
17	Bid submission fee	ITB - 3.7	Rs. 2500/- + GST @ 12% = Rs 2800/-
18	Bid Security	ITB - 3.6	Rs 50,000/-
19	Performance Guarantee	ITB - 7	5% of Contract amount
20	Performance Security Deposit	ITB - 7	at 2.5% from running bills

Sl. No	Item	Clause reference	Data
21	Insurance requirements are	GCC - 12	<p>a. The Contractor shall obtain insurance cover for a minimum of Rs.* per occurrence.</p> <p>b. The insurance cover shall be taken initially for a minimum of four occurrences, which shall be revised whenever an event involving Contractor's liability and Plant and Materials for payment arises, and additional insurances shall be taken so as to cover minimum four occurrences always.</p> <p>c: 0.2% of the Contract Amount shall be deducted in the event of failure to obtain the insurance by the contractor within 15 days of Start Date [* The value shall be generally 0.5% of the Contract Value subject to a minimum of Rs. 2.00 lakh and maximum of Rs. 5.00 lakh]</p>
22.	First Tier Quality control test/ Minimum tests to be conducted	GCC - 35.5	As per clause/s
23.	Defects Liability Period	GCC - 46	24 months from the date of completion of work as certified by the Engineer in charge
24	Price adjustment is applicable/not, if applicable give the percentages for calculation	GCC - 40	As per clause/s
25	Liquidated damages	GCC - 15	@ 1(one) percent of the contract price per week of delay or part thereof.
26.	Work items for which Guaranties required	GCC - 45	As per clause/s
27	Limit of subcontracting	SCC - 12	25% of Contract Value
28.	Maximum extent of change in quantity	GCC - 10	25% of BoQ quantity
29	Contractors Equipments and Tools and Plants	SCC - 17	As per clause/s
30	Whether mobilization advance applicable	SCC - 20.1	Not Applicable
31	Whether secured advance applicable	SCC - 20.2	Not Applicable
32	Deduction towards KVAT	SCC - 18	As per clause/s
33.	Deduction towards KCWWF	SCC - 19	At the rate of 1 % on the Gross bill amount
34	Recovery rate for excess bitumen	SCC - 15	Not Applicable
35	Recovery rate for not returning empty drum in good condition	SCC - 15	Not Applicable

Part V

TECHNICAL SPECIFICATIONS

1. General

- 1.1 The specifications and mode of measurements for Building works shall be in accordance with Central Public Works Department (CPWD) Specifications 2009 Volumes I and II and Kerala PWD Manual and that for Road and Bridge works shall be in accordance with MoRTH/IRC specifications with up to date correction slips unless otherwise specified in the nomenclature of individual item or in the individual item specification in the Bill of Quantities. The entire work shall be carried out as per the above specifications in force with up to date correction slips issued up to the date of opening of tender.
- 1.2. For the item not covered under CPWD Specifications mentioned above, the work shall be executed as per latest relevant standards/codes published by B.I.S. (formerly ISI) inclusive of all amendments issued thereto or revision thereof, if any, up to the date of opening of tenders.
- 1.3. In case of B.I.S. (formerly I.S.I) codes/specifications are not available, the decision of the Engineer based on standards prescribed by ASTM, BS, DIN, AASHTO and similar organisations or acceptable sound engineering practice and local usage shall be final and binding on the contractor. However, in the event of any discrepancy in the description of any item as given in the bill of quantities or specifications appended with the tender and the specifications relating to the relevant item as per CPWD/MoRTH or other specifications mentioned above, or in drawings the former shall prevail.
- 1.4. The work shall be carried out in accordance with the design and drawings furnished by the Department. The drawings shall have to be properly co-related before executing the work. In case of any discrepancy noticed between the drawings, final decision, in writing of the Engineer shall be obtained by the contractor. For items, where so required, by the relevant clause in PWD Quality Control Manual, samples shall be prepared before starting the particular items of work for prior approval of the Engineer and nothing extra shall be payable on this account.
- 1.5. All materials to be used on works shall bear I.S. certification mark unless specifically permitted otherwise in writing. In case I.S. Code or CPWD/MoRTH specifications, as applicable in this contract.
- 1.6. In such cases the Engineer shall satisfy himself about the quality of such materials and give his approval in writing. Only articles classified as "Premium/First Quality" by the manufacturers shall be used unless otherwise specified. First tier Quality Control tests for all materials and work shall be done as per the procedure and frequency detailed in PWD Quality Control Manual. Proper proof of procurement of materials from authentic manufacturers shall be provided by the contractor to the satisfaction of Engineer. Manufacturer's test certificate shall also be produced by Contractor as required in the relevant provisions of the PWD Quality Control Manual. The contractor shall carryout Mix Design for all RCC works done by the labs approved by the Government. Reinforcement steel and Cement shall be as per the Finance Department circular No-8/2016/Fin dated 4-2-2016.

- 1.7. In respect of the work of other-agencies deployed in the same site through a separate contract by the Employer for doing work like electrification, air-conditioning, external services, other building work, horticulture work, etc. and any other agencies simultaneously executing other works, the contractor shall afford necessary coordination and facilities for the same. The contractor shall leave such necessary holes, openings, etc. for laying / burying in the work pipes, cables, conduits, clamps, boxes and hooks for fan clamps, etc. as may be required for the electric, sanitary air-conditioning, fire fighting, PA system, telephone system, C.C.T.V. system, etc. and nothing extra over the agreement rates shall be paid for the same.
- 1.8. Unless otherwise specified in the bill of quantities, the rates for all items of work shall be considered as inclusive of pumping out or bailing out water if required for which no extra payment will be made. This will include water encountered from any source such as rains, floods, or due to any other cause whatsoever.
- 1.9. Any cement slurry added over base surface (or) for continuation of concreting for bond is added its cost is deemed to have in built in the item unless otherwise/explicitly stated and nothing extra shall be payable or extra cement considered with consumption on this account.
- 1.10. The rate for all items in which the use of cement is involved is inclusive of charges for curing.
- 1.11. The contractor shall clear the site thoroughly of all scaffolding materials and rubbish etc. left out of his work and dress the site around the building to the satisfaction of the Engineer before the work is considered as complete.
- 1.12. Rates for plastering work, if any (excluding washed grit finish on external wall surfaces) shall include for making grooves, bands, chicken wire mesh over joints etc. wherever required and nothing extra shall be paid for the same.
- 1.13. The rates quoted for all brick/concrete work shall be deemed to include making openings and making good these with the same specifications as shown in drawings and/or as directed. No extra payment shall be made to the contractor on this account.
- 1.14. Rates for all concrete/plaster work shall include for making drip course moulding, grooves etc. wherever required and no extra shall be paid for the same.
- 1.15. Rates for flooring work shall include for laying the flooring in strips/as per sample or as shown in drawings wherever required and nothing extra shall be paid for the same.
- 1.16. The drawing(s) attached with the tender documents are for the purpose of tender only, giving the tenderer a general idea of the nature and the extent of works to be executed. The rates quoted by the tenderer shall be deemed to be for the execution of works taking into account the "Design Aspect" of the items and in accordance with the "Construction Drawings" to be supplied to the Contractor during execution of the works.
- 1.17. The quoted rate shall be for finished items and shall be complete in all respects including the cost of all materials, labour, tools & plants, machinery etc., all taxes, duties, levies, octroi, royalty charges, statutory levies etc. applicable from time to time and any

other item required but not mentioned here involved in the operations described above. The Employer shall not be supplying any material, labour, plant etc. unless explicitly mentioned so.

- 1.18. There could be some restrictions on the working hours, movement of vehicles for transportation of materials and location of labour camp. The contractor shall be bound to follow all such restrictions and adjust the programme for execution of work accordingly.
- 1.19. The contractor shall also ensure that all work sites within the site are properly cordoned off by means of barricades and screens up to a height of 3.0 m above ground level at his own cost. The contractor shall use pre-coated GI sheets which are in good condition mounted on steel props.
- 1.20. Stacking of materials and excavated earth including its disposal shall be done as per the directions of the Engineer-in-Charge. Double handling of materials or excavated earth if required shall have to be done by the contractor at his own cost.
- 1.21. The Contractor will have to take prior approval of the Engineer-in charge for the Make of materials before procurement of the same. It may also be noted that if any of the makes does not comply with Standards, it will not be allowed for use. No claim what so ever shall be entertained on this account.
- 1.22. The contractor shall clear the site of all rubbish, remove all grass and low vegetation and remove all bush wood, trees, stumps of trees, and other vegetation only after consultation with the Field Engineer as to which bushes and trees shall be saved.
- 1.23. The contractor shall carry out the survey of the site and shall establish sufficient number of grids and level marks to the satisfaction of the Engineer-in-charge, who shall decide on the basis of this information, the general levels of the construction works.
- 1.24. Prior to commencement of construction, the contractor shall in consultation with the Engineer-in-charge, establish several site datum bench-marks, their number depending on the extent of the site. The bench-marks shall be sited and constructed so as to be undisturbed throughout the period of construction.
- 1.25. The Engineer-in charge might have got the soil investigation done and if so, copy of the report will be handed over to the contractor for their scrutiny upon specific request by the Contractor. The Contractor shall however inspect the site and study the findings from the trial pits or bores in order to assess the problems involved in and methods to be adopted for excavation and earthwork. The contractor shall ascertain for himself all information concerning the sub-soil conditions, ground water table levels and intensity of rainfall, flooding of the site and all data concerning excavation and earthwork. The Employer shall not be responsible for any later claims of the contractor for any extra work required to be done on account of this and shall not pay any extra amount in this regard.
- 1.26. The Contractor shall set out the works using Total Station and during the progress of the building shall amend at his own cost any errors arising from inaccurate setting out. During the execution of the work contractor must cross check his work with the drawings. The contractor shall be responsible for all the errors in this connection and

shall have to rectify all defects and/or errors at his own cost, failing which the Engineer-in charge serves the right to get the same rectified at the risk and cost of the contractor.

1.27. Cleaning up and handing over: Upon completion of the work all the areas should be cleaned. All floors, doors, windows, surface, etc. shall be cleaned down in a manner which will render the work acceptable to the Engineer-in-charge. All rubbish due to any reason, shall be removed daily from the site and an area of up to ten metres on the outer boundaries of the premises will be cleaned by the contractor as a part of the contract. Upon completion of the Work, the contractor shall hand over to the Assistant Engineer the following:

- a. Written guarantee and certificates
- b. Maintenance manuals, if any, and
- c. Keys.

1.28. Samples: The contractor shall submit to the Engineer-in charge samples of all materials for approval and no work shall commence before such samples are duly approved. Samples of materials for concrete works, masonry units, building insulation, finished hardware, door and windows, flooring materials etc. and every other work requiring samples as detailed in the PWD Quality Control Manual or as required by the Engineer-in charge shall be supplied to them and these samples will be retained as standards of materials and workmanship. The cost of procuring the samples shall be borne by the contractor. Throughout this specification, types of material may be specified by manufacturer's name in order to establish standard of quality, price and performance and not for the purpose of limiting competition. Unless specifically stated otherwise, the Bidder may assume the price of 'approved equivalent' except that the burden is upon the contractor to prove such equality, in writing.

1.29. Tests: All materials and methods of tests shall conform to the latest rules, regulation and/or specifications as per the provisions laid out in the PWD Quality Control Manual and PWD Quality Control Laboratory Manual. The Engineer-in charge will have the option to have any of the materials tested and if the test results show that the materials do not conform to the specifications, such materials shall be rejected. The expenses to carry out tests as per frequency and procedure detailed in the PWD Quality Control Manual and PWD Quality Control Laboratory Manual will be deemed to be included in the Rates quoted.

1.30. Mode of Measurements: All measurements will be taken in accordance with CPWD manual.

1.31. The rates tendered by a Bidder for the work shall include the cost of:

- a. All labour and supervision thereof, all materials, tools, implements and plant of every description, ladders, cordage tackle, etc. as well as the provision of safe and substantial scaffolding required for the proper execution of the work in conformity with the various items of work;
- b. Supplying the requisite agency with necessary equipments, to set out the work as well as to afford facilities for such examination of the work as the Departmental Officers may at any time consider desirable, as also to count, weigh and assist in the measurement or check measurement of the work or materials;

- c. Providing and maintaining all temporary fences, shelters, lights , watchmen and danger signals and such other precautions as are necessary for the protection of the work or materials, as well as to protect the public and those connected with the work from accidents at the site of, or on account of the work;
 - d. All sheds, mortar mills and mixing platform of every kind required for the proper execution of the work according to the specifications;
 - e. All fees and royalties of materials and
 - f. Finally clearing away of all rubbish, surplus materials, plant etc. on completion of the work and dressing and leveling of and restoring the site to a tidy condition, prior to **handing over the work to the Engineer in charge and also its maintenance until so** taken over.
- 1.32. In the case of supplies of materials such as rubble, broken stones, gravel, sand etc. which may have to be measured prior to being used on the work, the Bidder must always stack or arrange them neatly on level ground or on ground cleared and levelled by him for the purpose in such manner as may be ordered by the Engineer so that they may be easily susceptible for inspection and measurement, the cost of such clearing, levelling and stacking or arranging being included in the rates for work. Each stack must be straight and of uniform section throughout and of the dimensions specified by the Field Engineer. Materials not stacked or arranged in accordance with instructions issued will not be measured and paid for.
- 1.33. The Bidder should state whether he has all the plant necessary for execution of the work. If the opinion of the Engineer-in charge, Bidder's own plant is neither sufficient nor suitable for the proper execution of the work, the department may supply other available plant and recover hire charges for the same. The decision of the Engineer-in charge in the matter shall be final and binding on the Contractor.
- 1.34. The Contractor shall bear the running expenses inclusive of pay of the departmental staff attached to such plant and cost of repairs of all Government plant while in his possession on hire as also the cost of restoring the same in good condition at the time of return, due allowance being made for fair wear and tear.
- 1.35. All materials and plant that are to be made over to the Bidder by the Department shall be handed over to him at the Section Office Store/yard and the charges for their handling, loading and unloading and conveyance to and from for the respective work as also for stacking the materials neatly and in regular heaps on the ground or sheds to which they are brought shall be deemed to be included in the rates for the work.
- 1.36. Unless otherwise specifically provide for in the Contract, the Contractor shall at his own cost keep all portions of the work free from water whether due to springs, or inclement weather and neat and sanitary condition and shall also see that drainage and sewage are prevented from entering the site of work or accumulating therein.
- 1.37. The Bidder shall be responsible for the proper use and bear the cost of protection of materials made over to him by the Department for use on the work and bear any loss form deterioration of from faulty workmanship or any other cause. The cost of materials thus allowed to deteriorate amounting as it does to and excess issue over sanctioned

quantities, will be recovered at rates 20 percent over the actual cost. The orders of the Engineer-in charge in the matter shall be final binding on the Contractor.

- 1.38. The Contractor shall be responsible to see that the level or the other pegs, profiles, bench, marks masonry pillars or other marks set up by the Department for guidance in the execution of the work are not disturbed, removed or destroyed. If the same is disturbed, it will be replaced by the Engineer at the cost of the Contractor.
- 1.39. Any materials brought to the site of work, or any work done by the Contractor but rejected by the Engineer-in-charge as being not up to the specifications shall in the case of materials supplied be then and there removed from or broken up at the site of work, and in the case of work done, be dismantled or rectified at the expense of the Contractor, as may be ordered by the Engineer-in-charge.
- 1.40. In all cases whether so specified in the contract or not, the work shall be executed in strict accordance with the Contractor's accepted bid and these specifications and with such further drawings and specifications and orders as may from time to time be issued by the Engineer-in charge.

Part VI

FORMS AND DECLARATIONS

1. FORM OF TENDER

Name of Work: **Construction of SMART village office at Nagaroor in Thiruvananthapuram**

To

Senior Manager (Projects),
Projects Division,
HLL Lifecare Limited (A Government of India Enterprise)
Corporate Head Office, Poojappura.P.O,
Thiruvananthapuram – 695012,
Kerala, India
Phn: 0471- 2354949, 2775588

Sir,

I/We do hereby tender to execute the works enumerated in the Schedule accompanying in accordance with the terms in your tender Notification _____ date.....and specifications and conditions of contract in the bidding document.

1. Copy of the electronically signed specifications signed is also enclosed.
2. I/We further agree to complete the whole work in..... Days/weeks/months from date of receipt of order to start work, and / or in the case of piece-works, maintain the minimum rate or progress specified in the Tender Schedule.
3. I/We do/do not agree to accept and carry out such portion of the work included in my/our tender as may be allotted to me /us if the whole work be not given to me/us.
4. In consideration I/We being invited to tender, I/We agree to keep the tender open for acceptance.....days from the date of submission thereof and not to make any modifications in its terms and conditions which are not acceptable.
5. I/We agree that Arbitration shall not be a means of settlement of any disputes or claims arising out of the contract relating to the work.

A sum of Rs..... is hereby remitted online on the e-GP website as Bid security/Earnest Money. If I/We fail to keep the tender open as aforesaid or make any modifications in that terms and conditions of the tender which are not acceptable.

OR

If after tender is accepted, I/We fail to execute the agreement as provided in clause ___ of tender notifications or to commence the execution of the work as provided in the conditions. I/We agree that the tender inviting authority shall, without prejudice to any other right or remedy be at liberty to forfeit the said earnest money/ Bid security absolutely and also recover from me/us the entire loss that may be caused to the PMC/Client Department by the retender or rearrangement of the work or otherwise under the provision of the Revenue Recovery Act or otherwise.

Acc:

- I. Tender Schedule (submitted with Financial Bid) :
- II. Earnest Money Rs.....
- III. Signed copy of full tender/bid documents:
- IV. Signed copy of drawings :

Nationality:

Signature

Full Name of Bidder:

Place of Residence:

2. PRELIMINARY AGREEMENT FORMAT

PRELIMINARY AGREEMENT

(To be executed on stamp per Rs.200/-)

Preliminary Agreement entered into on this day of.....
Two thousand and.....between HLL Lifecare Limited (HLL),
Thiruvananthapuram (hereinafter referred as Project Management Consultant (PMC)) for and
on behalf of The District Collector, Thiruvananthapuram (hereinafter called for
Client/Department) of the one part and

Sri.....(here enter full name and address
of the Bidder) hereinafter called the Bidder of the other part for the execution of the agreement
as well as for the execution of the work

.....
WHEREAS the PMC invited tenders for the work of
..... (here enter
name of the work) by Tender reference No.....
Dated.....In the.....

I/We undersigned hereby offer to construct the proposed work in strict accordance with the
contract/bid document for the consideration to be calculated in terms of the priced schedule of
quantities.

I/We undertake to complete the whole of the works as per the attached schedule from the date
of issue of intimation by you that our tender has been accepted and upon being permitted to
enter site. I/We further undertake that on failure, subject to the conditions of the contract relating
to extension of time, I/We shall pay agreed 'Liquidated Damages' for the period during which
the work shall remain incomplete.

I/We hereby deposit with you as Earnest money/Bid security Rs.-/- (Rupees
.....)
[carrying no interest] by means of online payment in the e-GP web site of Kerala in favour of
HLL Lifecare Limited (HLL), Thiruvananthapuram and I/We agree that this sum shall be forfeited
in the event of the Employer accepting my/our tender and I/We fail to take up the contract when
called upon to do so as per clause 3.6.6 and 7 of ITB of the bid document.

I/We further agree for the deduction of 2.5% from the 'Interim Payment/RA Bill' and up to a
maximum of 2.5% of the contract value towards the 'Performance Security Deposit', which will
be returned as per the relevant clauses in the agreement.

I/We will furnish the Performance Guarantee if our bid is accepted. Bid Security deposited shall be treated as security for the proper fulfilment of the same and shall execute an agreement for the work in the prescribed form. If I/We fails to do this or maintain a specified rate of progress (as specified in the Milestone details of contract data in the bid document), the performance guarantee and Performance Security Deposit if any deducted from the RA Bills shall be forfeited to PMC/Client Department and fresh tenders shall be called for or the matter otherwise disposed off. If as a result of such measures due to the default of the Bidder to pay the requisite deposit, sign contract or take possession of the work any loss to PMC/Client Department due to the same will be recovered from me/us as arrears of revenue, but should it be a saving to PMC/Client Department. I/We shall have no claim whatever to the difference. Recoveries on this or any other account will be made from the sum that may be due to us on this or any or other subsisting contracts or otherwise the PMC/Client department may decide.

I/We further agrees that, in the case of becoming the lowest bidder in this tender and in the event of failure on part of me/us to produce any of the original documents, or submit the performance guarantee, or enter into agreement with the first party within the specified time limit, the first party may take appropriate action as provided in the bid document. Recoveries on this or any other account will be made from the sum that may be due to us on this or any or other subsisting contracts or otherwise the PMC/Client department may decide.

NOW THEREFORE IN THE PRESENCE OF WITNESS it is mutually agreed as follows.

- a.1) The terms and conditions for the said contract having been stipulated in the said tender document and forms to which the I/We have agreed and a copy of which is here to be appended which forms the part of this agreement, it is agreed that the terms and conditions stipulated therein shall bind the parties to this agreement except to the extend to which they are abrogated or altered by express terms and conditions herein agreed to and in which respect the express provisions herein shall supersede those of said tender form.
- a.2) The I/We hereby agreed and undertake to perform and fulfill all the operations and obligations connected with the execution of the said contract work
..... (herein after the name of the work if awarded in favour of the me/us.)
- a.3) If the Bidder does not come forward and to execute the original agreement after the said work is awarded and selection notice issued in his favour or commits breach of any of the conditions of the contract as stipulated in clause of the notice inviting tenders as quoted above, within the period stipulated then the Government may rearrange the work otherwise or get it done departmentally at the risk and the cost of the Bidder and the loss so sustained by the PMC/Client Department can be realized from the Bidder.
- a.4) The Bidder further agrees that any amount found due to the PMC/Client Department under or by virtue of this agreement shall be recoverable from the Bidder from his Bid security (EMD) or in any other manner as the PMC/Client Department may deem fit in this regard.

- a.5) The Bidder further assures that it is clearly understood that the settlement of claims either by part bills or by final bills will be made only according to the availability of budget provision and allotment of funds made with the Client Department under the respective heads of account in which the work is sanctioned and arranged and also subject to the seniority of such bills. No claims for interest or for damages whatsoever shall be made for the related settlement of claims of bills.

IN WITNESS WHEREOF the parties hereto have caused these presents to be signed by their respective offices and to affix the common seal in the presence of the following witnesses on the day and year first above written.

Signed and delivered by

Signed and delivered for and on behalf of:
(Name and Address of Bidder)

HLL Lifecare Ltd
(Project Management Consultant),
HLL Bhavan, Poojappura
Thiruvananthapuram

In the presence of
Witnesses

1.

2.

In the presence of
Witnesses

1.

2.

3. Format for Integrity Pact

(Certificate to be furnished by the bidder with the tender document downloaded from e-GP Website)

CERTIFICATE

I/We..... undertake that the tender submitted by us is downloaded from e-GP Website (www.etenders.kerala.gov.in) and is same in content and form (verbatim), and any deviation, if detected, at any stage, would entitle the Employer to reject our bidding/offer without assigning any reason or recourse to any penal action and would be legally binding on us.

Signature..... (of tenderer)

Seal.....

4. Format for Affidavit

Non-Judicial Stamp Paper

AFFIDAVIT

I/We,, bidder/Partner/Legal Attorney/Accredited Representative of M/s solemnly declare that:

- 1) I/We are submitting Tender for the Work against Tender Notice No..... dated
- 2) None of the Partners of our firm is relative of employee of (Name of the Employer) who is involved with the arrangement and execution of this work.
- 3) All information furnished by us in respect of fulfilment of eligibility criteria and qualification information of this Tender is complete, correct and true.
- 4) All documents/credentials submitted along with this Tender are genuine, authentic, true and valid.
- 5) I/we undertake to deploy all plant and machinery, tools and tackles, man and materials etc. as required for execution of the work.
- 6) I/We hereby declare that I/We have perused in detail and examined closely the Central Public Works Department Specifications, Revised Kerala PWD Manual-2012, Kerala PWD Quality Manual and Laboratory Manual, before I/We submit the tender/ bid and I/We agree to be bound by and comply with all such specifications and requirements.
- 7) If any information and document submitted is found to be false/incorrect at any time, department may cancel my/our Tender and action as deemed fit may be taken against us, including termination of contract, forfeiture of all dues including Bid security (Earnest Money), Forfeiture of Performance guarantee and banning/delisting of our firm and all partners of the firm etc.

Signature of the Tenderer,

Seal of Notary

Dated

Note: Only signed and sealed document in Non-Judicial Stamp Paper by the bidder to be submitted online. Original with Seal of Notary shall be submitted in the PMC office after notification of award of work and before the issue of work order.

5. Requisition Form for e-Payment

Requisition for e-Payment

Certified that I am having a Savings / Current Account in <Name of Bank> at <Name of Branch> with IFSC Code _____

The Account Number is: _____

I wish to receive all payments in this account through NEFT and RTGS systems, as the case may be, for all payments relating to this work.

Name of Bidder

Place: _____

Date: _____

6. SAMPLE GUARANTEE BOND for termite-proof/water and leak-proof work.

This AGREEMENT made this..... day of Two thousand Between M/s (hereinafter called the guarantor/ Contractor of the one part) andon behalf of HLL Lifecare Limited (PMC) of the other part

WHEREAS this agreement is supplementary to the contract (hereinafter called the Contract) dated made between the Guarantor of the one part and the Employer of the other part, whereby the Contractor, inter alia, undertook to render the buildings and structures in the said Contract recited, completely termite-proof/water and leak-proof.

AND WHEREAS the Guarantor agreed to give a guarantee to the effect that the said structure will remain termite-proof for ten years to be reckoned from the date after the maintenance period prescribed in the contract expires.

During this period of guarantee the Guarantor shall make good all defects and for that matter, shall replace at his risk and cost such wooden members as may be damaged by termites, and in case of any other defect being found he shall render the building waterproof/termite-proof at his cost to the satisfaction of the Engineer-in-charge, and shall commence the works of such rectification within seven days from date of issuing notice from the Engineer-in-charge/Competent authority calling upon him to rectify the defects, failing which the work shall be got done by the Department by some other Contractor at the Guarantor's cost and risk, and in the later case the decision of the Engineer-in-charge as to the cost recoverable form the Guarantor shall be final and binding.

That if the Guarantor fails to execute the waterproofing/anti-termite treatment or commits breaches hereunder then the Guarantor will indemnify principal and his successors against all loss, damage, cost, expense or otherwise which may be incurred by him by reason of any default on the part of the Guarantor in performance and observance of this supplemental agreement. As to the amount of loss and/or damage and/or cost incurred by the PMC/Client Department, the decision of the Engineer-in-charge will be final and binding on the parties.

IN WITNESS WHEREOF these presents have been executed by the Obligor and by for and on behalf of HLL Lifecare Limited on the day, month and year first above written.

Signed, sealed and delivered by OBLIGOR in the presence of witnesses

- 1.
- 2.

Signed for and on behalf of HLL Lifecare Limited by in the presence of witnesses

- 1.
- 2.

Part VII

DRAWINGS

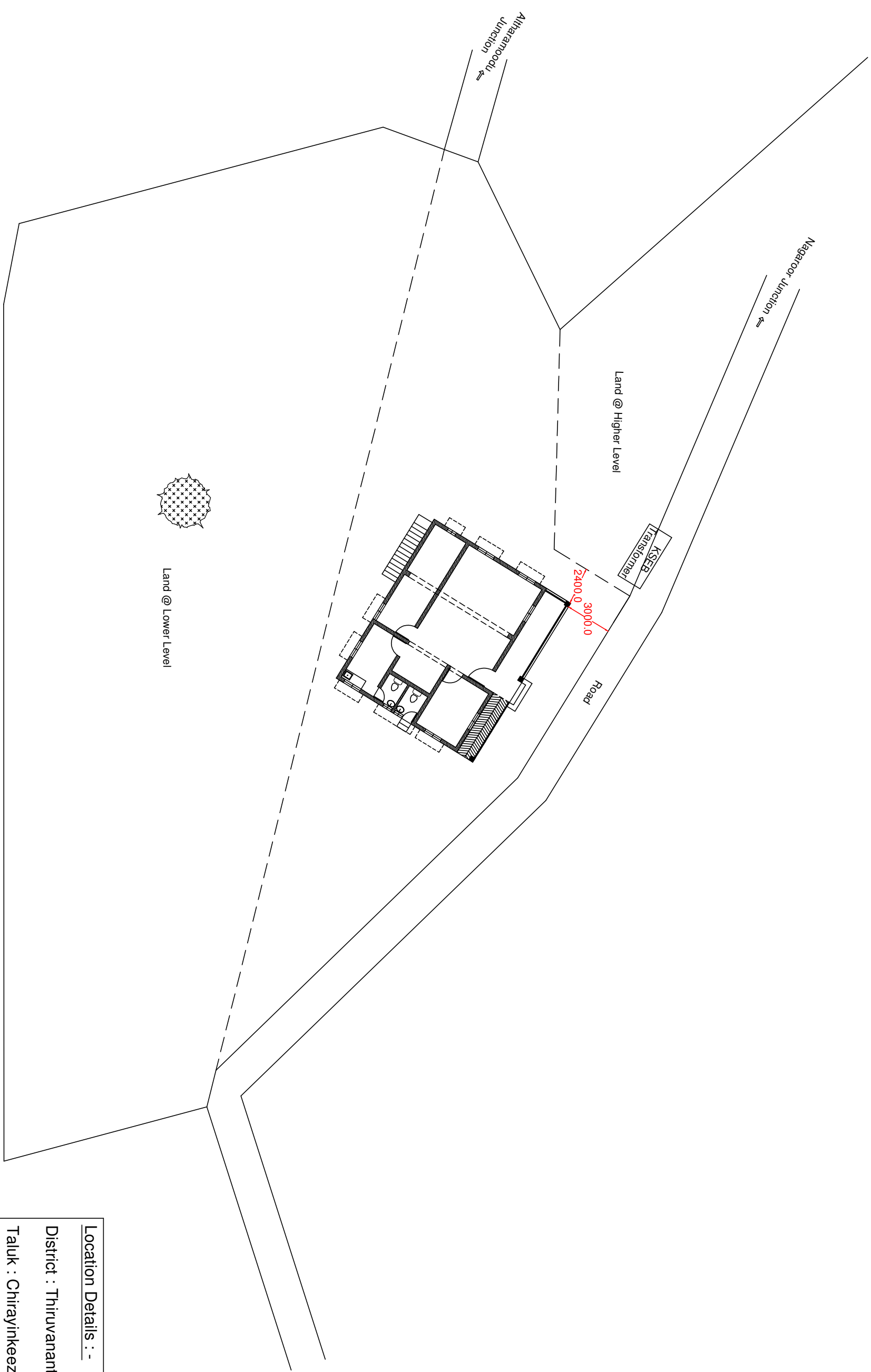
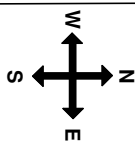

Tree



Land @ Lower Level

Location Details :-
District : Thiruvananthapuram
Taluk : Chirayinkeezhu
Village : Nagaroor
Re Survey No : 471/9

**HLL Lifecare Limited**
(A Government of India Enterprise)
PROJECTS DIVISION
CORPORATE & REGD. OFFICE
HLL BHAVANI, POOJA PURAM
THIRUVANANTHAPURAM
KERALA - 695 012

TITLE:-
SMART VILLAGE OFFICE, NAGARROOR -
PROPOSED SITE LAYOUT

DRAWN BY:	SARATH KRISHNA	DRG NO:	HLL-PROJ-EXT-SVO-001	REVISION:	00
CHECKED BY:	AJITH KUMAR S	SITE:	NAGARROOR, CHIRYINKEEZHU TALUK, THIRUVANANTHAPURAM DISTRICT	DATE :	15.10.18
APPROVED BY:	HARIKRISHNAN K P	ISSUED FOR:	TENDERING	SHEET NO:	01/05
DATE:	15.10.2018	This drawing is the Sole Property of M/s:HLL Lifecare Ltd. The contents of this drawing shall not be reproduced in any manner or used for other purposes than the intended one.			
SCALE:	NOT TO SCALE				
ALL DIMENSIONS ARE IN MILLIMETER					

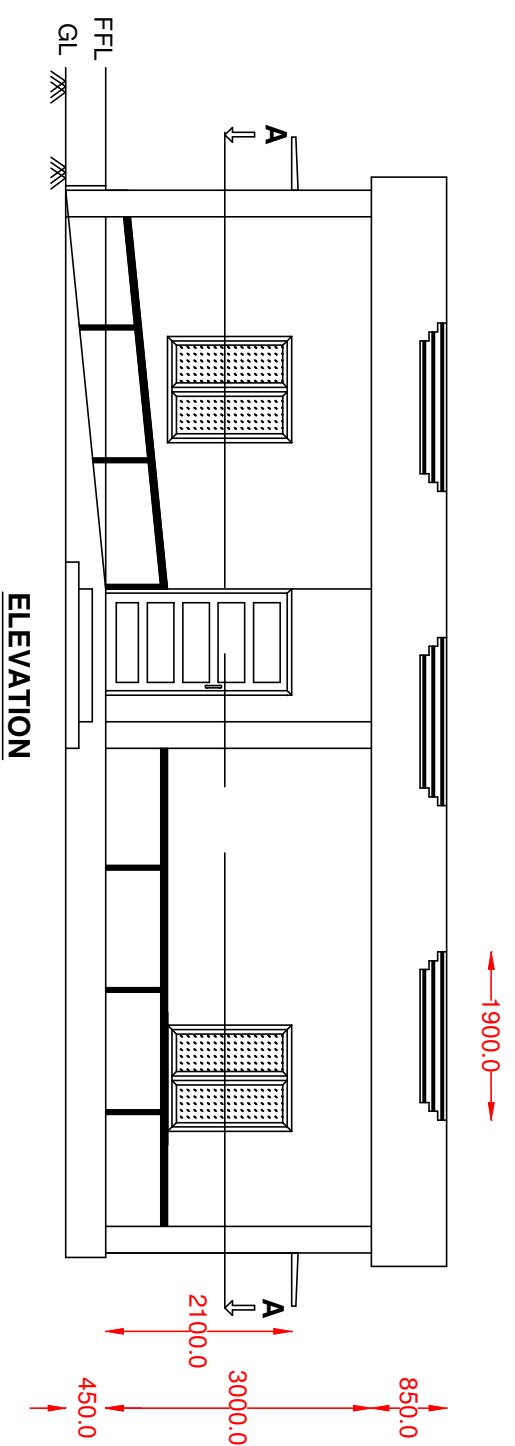

ELEVATION

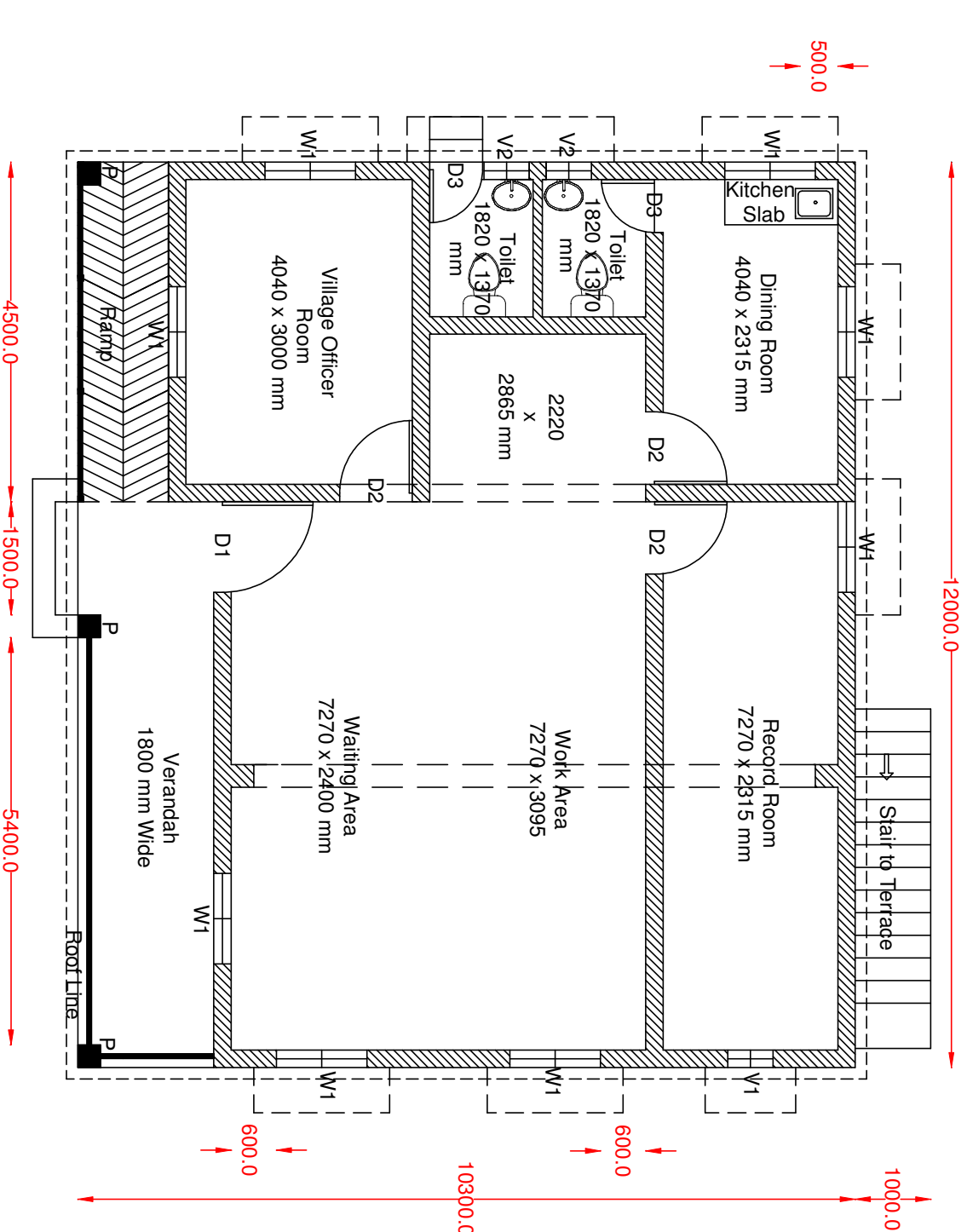

PLAN (Section A-A)

Carpet Area Details in Sq.M		Details	
Village Officer Room	12.12	D1	Single Door W 1200 x H 2100 mm
Waiting Area	17.45	D2	Single Door W 1000 x H 2100 mm
Work Area	28.86	D3	Single Door W 800 x H 2100 mm
Record Room	16.83	W1	Window W 1200 x H 1400 mm
Dining Room	9.35	V1	Ventilation W 600 x H 300 mm
Staff Toilet	2.50	V2	Ventilation W 600 x H 450 mm
Public Toilet	2.50	GL	Ground Level
Verandah	13.50	FFL	Finished Floor Level
Ramp	5.40	P	Pillar 300 x 300 mm
Total	108.51 Sq. M		

Note :-

- Flooring :-
Room : Vitrified Floor Tile
Ramp : Vitrified Anti Skid Tile
Toilet : Ceramic Floor Tile
- Wall :-
All Walls shown are Brick Wall.
- Stair :-
Metallic Stairs open to Terrace from Ground Level
- Ramp :-
Ramp for Wheel Chairs with Standard Slope 1:10.
- Hand Rail :-
Stainless Steel Hand Rail.
- Ceiling :-
False Ceiling @ 2700 mm Height FFL in Work Area, Waiting Area & Village Officer Room only (58.43 Sq. M).
- Plinth Protection
PCC Plinth Protection @ 600 mm Width through out.
- Kitchen Slab
Granite Top Kitchen Slab W 600 x L 1500 x H 700 mm
- Window
Window Sill Level : 700 mm FFL
- Lintel
Lintel Bottom Height : 2100 mm FFL
- Roofing
RCC Roofing

Plinth Area : 123.6 Sq. M

 HLL Lifecare Limited <small>(A Government of India Enterprise)</small> <small>CHIRAYINKEEZHU TALUK, THIRUVANANTHAPURAM DISTRICT, KERALA - 686 012</small>		<small>PROJECTS DIVISION</small> <small>CORPORATE & REGD. OFFICE</small> <small>THIRUVANANTHAPURAM</small> <small>KERALA - 686 012</small>	
TITLE:-	SMART VILLAGE OFFICE, NAGARROOR - PROPOSED CIVIL LAYOUT		
DRAWN BY:	SARATH KRISHNA	DRG NO:	HLL-PROJ-EXT-SVO-001
CHECKED BY:	AJITH KUMAR S	DATE:	15.10.18
APPROVED BY:	HARIKRISHNAN K P	ISSUED FOR:	TENDERING
SCALE:	NOT TO SCALE	SHEET NO:	02/05
<small>ALL DIMENSIONS ARE IN MILLIMETER</small>			

This drawing is for Tendering Purpose Only. Subjected to change as per site conditions.

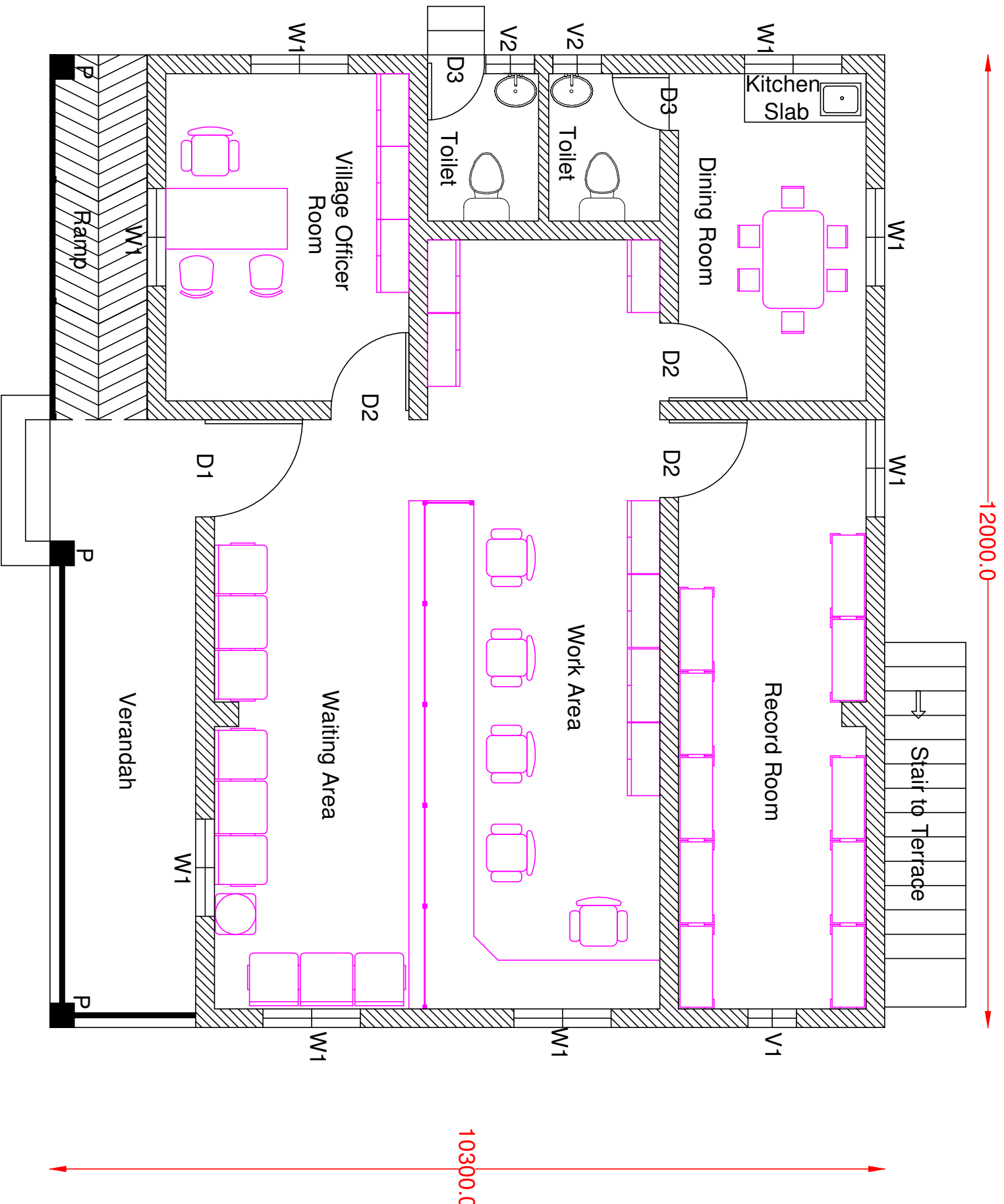

Details

	Officer Table with Side Table L 1500 x W 750 mm
	Dining Table L 1200 x W 750 mm
	Computer Chair
	Armed Chair
	Visitors Chair (3 Seater)
	Dining Chair
	Cupboard W 900 x H 2100 mm
	File Storage Rack
	Drinking Water Dispenser
	Work Station

For Details of Workstation, Refer Drawing No :
HLL-PROJ-EXT-SVO-001 Sheet No. 04/05

This drawing is for Tendering Purpose Only.
Subjected to change as per site conditions.

<p>HLL Lifecare Limited (A Government of India Enterprise) CORPORATE & REGD. OFFICE THIRUVANANTHAPURAM KERALA - 595 012</p>		<p>PROJECTS DIVISION CORPORATE & REGD. OFFICE THIRUVANANTHAPURAM KERALA - 595 012</p>	
DRAWN BY:	SARATH KRISHNA	DRG NO:	HLL-PROJ-EXT-SVO-001
CHECKED BY:	AJITH KUMAR S	DATE:	15.10.2018
APPROVED BY:	HARIKRISHNAN K P	SITE:	NAGARCOOR, CHIRAYINKEEZHU TALUK, THIRUVANANTHAPURAM DISTRICT
SCALE:	NOT TO SCALE	ISSUED FOR:	TENDERING
ALL DIMENSIONS ARE IN MILLIMETER		SHEET NO:	03/05

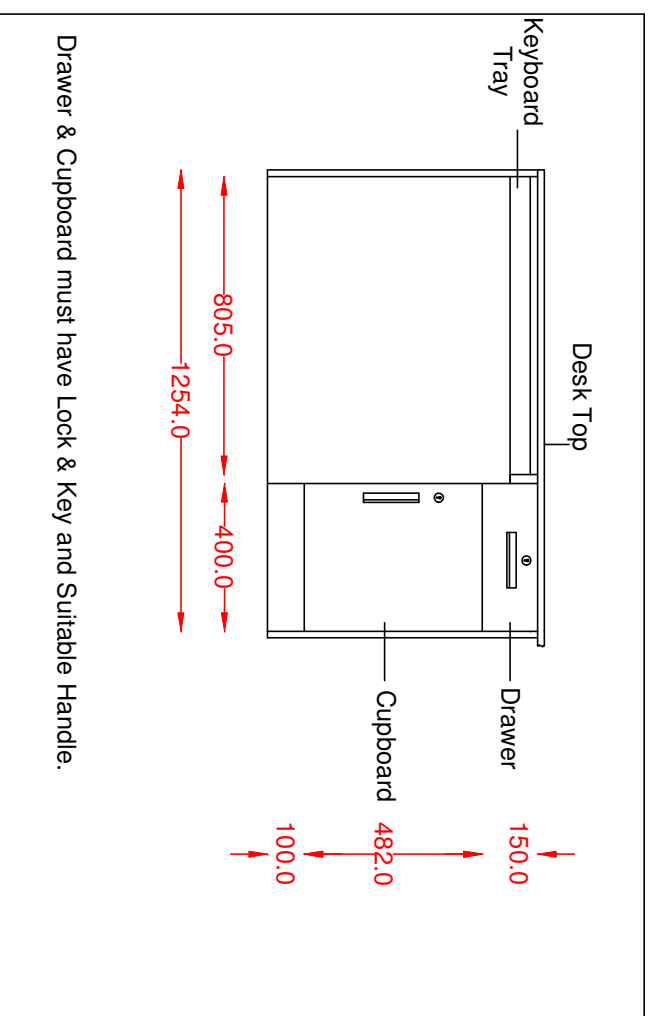
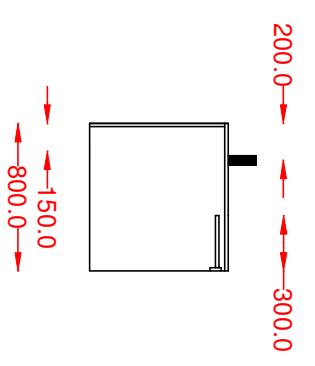
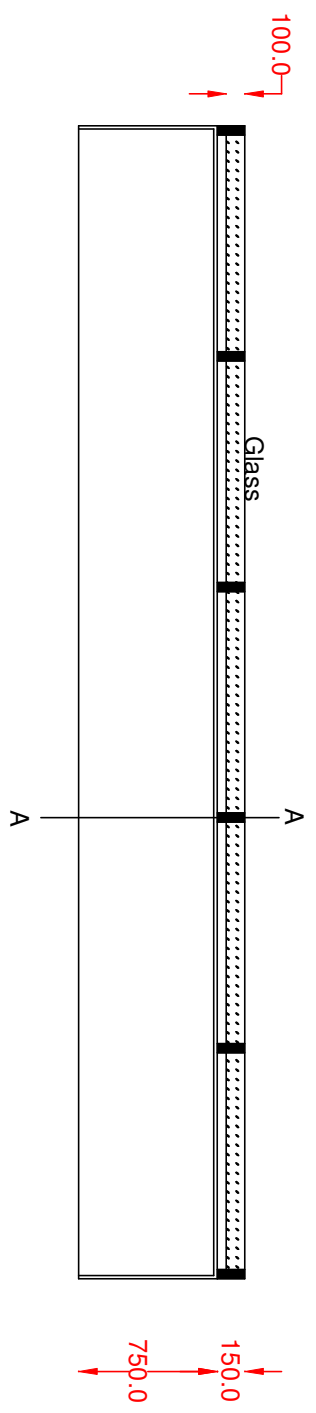
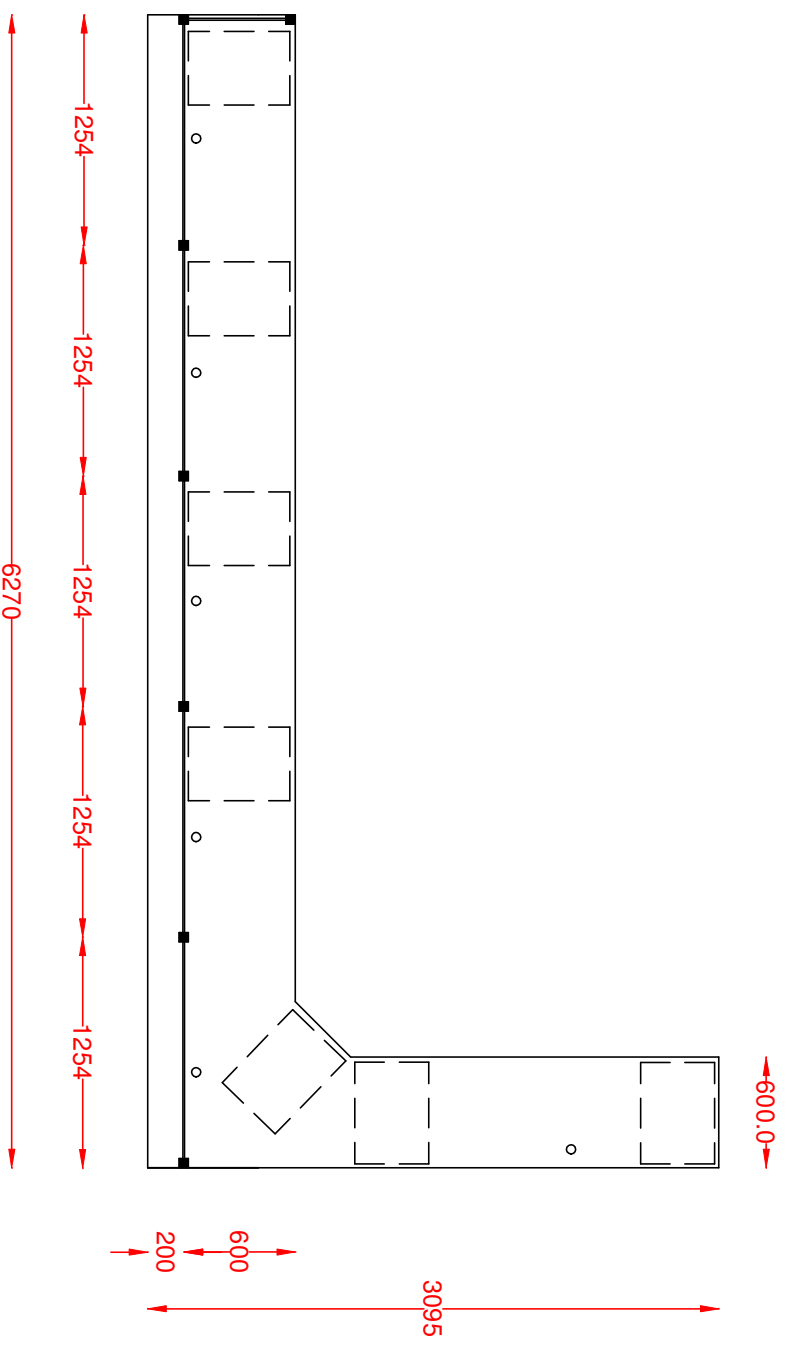

Material : As specified in Schedule

 HLL Lifecare Limited <small>(A Government of India Enterprise)</small>		<small>PROJECTS DIVISION CORPORATE & REGD. OFFICE CHIRAYINKKEEZHU TALUK, THIRUVANANTHAPURAM DISTRICT KERALA - 696 012</small>	
DRAWN BY:	SARATH KRISHNA	DRG NO:	HLL-PROJ-EXT-SVO-001
CHECKED BY:	AJITH KUMAR S	REVISION:	00
APPROVED BY:	HARIKRISHNAN K P	DATE:	15.10.18
DATE:	15.10.2018	ISSUED FOR:	TENDERING
SCALE:	NOT TO SCALE	SHEET NO:	04/05
<small>ALL DIMENSIONS ARE IN MILLIMETER</small>			

This drawing is for Tendering Purpose Only. Subjected to change as per site conditions.

TITLE: SMART VILLAGE OFFICE, NAGARROOR - PROPOSED WORKSTATION - DETAILS

This drawing is the Sole Property of M/s. HLL Lifecare Ltd. The contents of this drawing shall not be reproduced in any manner or used for other purposes than the intended one.

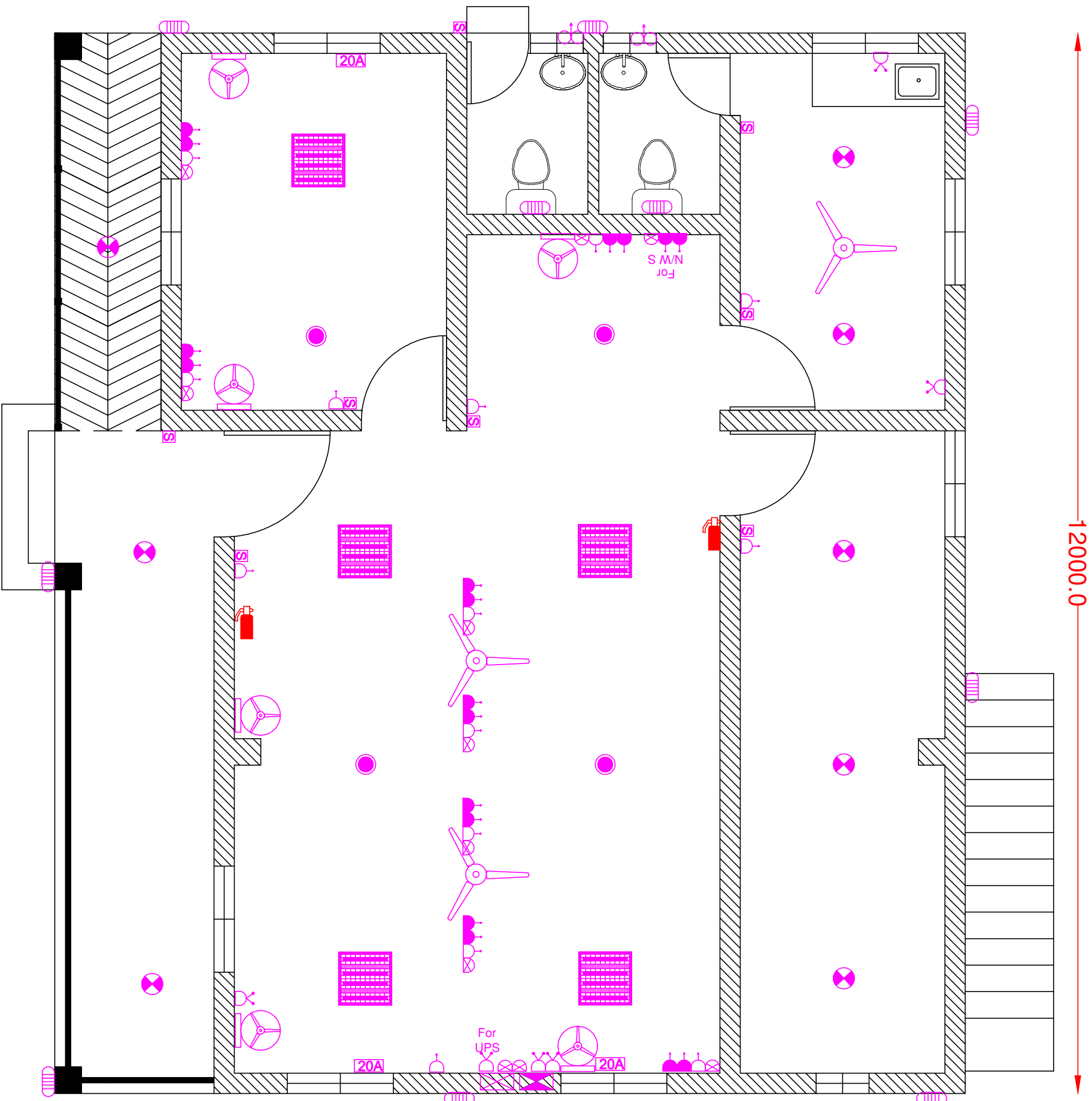

12000.0

10300.0

Details	
	1 x 5 A Power Socket (Raw Power)
	2 x 5 A Power Socket (UPS Power)
	2 x 5 A Power Socket for Network Switch (UPS Power)
	1 x 15 A Power Socket
	1 x 15 A Power Socket for UPS
	1 x 20 A Industrial Power Socket for AC
	RJ-45 Data Outlet
	4 x 14 W Recess Type CFL Box Fitting
	1 x 15 W LED Recess Type Round Fitting
	1 x 15 W LED Surface Type Round Fitting
	1 x 18 W CFL Bulk Head Lamp
	Switch Box (Light and Fan Control)
	1200 mm Sweep Ceiling Fan
	450 mm Sweep Wall Mounted Fan
	12 Way SPN Distribution Board (UPS Power)
	4 Way TPN Distribution Board (Raw Power)
	Fire Extinguisher
	300 mm Sweep Exhaust Fan

Wall Fittings Fixing Height FFL	
Switch Box (Light and Fan Control)	1200 mm
Power Socket (5A & 15A)	1200 mm
Wall Mount Fan	1800 mm
Power Socket (20 A)	2400 mm
Wall Mounted Light	2400 mm
Power Socket for Network Switch	2400 mm
Power Socket in Workstation	400 mm

This drawing is for Tendering Purpose Only.
Subjected to change as per site conditions.

HLL Lifecare Limited (A Government of India Enterprise) CORPORATE & REGD. OFFICE THE BHAWAN, THAPURAM KERALA - 695 012		PROJECTS DIVISION CORPORATE & REGD. OFFICE THE BHAWAN, THAPURAM KERALA - 695 012	
DRAWN BY:	SARATH KRISHNA	DRG NO:	HLL-PROJ-EXT-SVO-001
CHECKED BY:	AJITH KUMAR S	DATE:	15.10.18
APPROVED BY:	HARIKRISHNAN K P	ISSUED FOR:	TENDERING
SCALE:	NOT TO SCALE	SHEET NO:	05/05
TITLE: SMART VILLAGE OFFICE, NAGAROOR - PROPOSED ELECTRICAL & SERVICES LAYOUT			
SITE: NAGAROOR, CHIRAYINKEEZHU TALUK, THIRUVANANTHAPURAM DISTRICT			
This drawing is the Sole Property of M/s. HLL Lifecare Ltd. The contents of this drawing shall not be reproduced in any manner or used for other purposes than the intended one.			