

HLL LIFECARE LIMITED
(A Government of India Enterprise)
Projects Division
Corporate Head Office, Poojappura.P.O,
Thiruvananthapuram – 695012,
Kerala, India
Phn: 0471- 2354949, 2775588

INVITATION FOR BIDS (IFB) – AMENDMENT NO: 1

Sub: Amendment No: 1- Supply and installation of partition storage cabinets for the Renovation of Nursery Block at Kerala State Jawahar Balbhavan, Thiruvananthapuram

Ref: Our IFB Ref No: HLL/CHO/PROJ/EXT/BALA/NUR-CAB /2018-19 dated 26-12-2018

Amendment Date: 09-01-2019

1. With reference to the above, the scheduled date for submission and opening of bids is hereby amended as follows.

- | | |
|---|--------------------------------------|
| a) Date of issue of tender document | - 26 -12 -2018 onwards |
| b) Last date and time for submission of bids | - 16-01-2019 up to 15.00 Hrs. |
| c) Date and time of opening of bids | - 16-01-2019, 15.30 Hrs. |

2. Layout of storage cabinets attached below.

All other terms and conditions of the tender remain unchanged.

SENIOR MANAGER (PROJECTS)

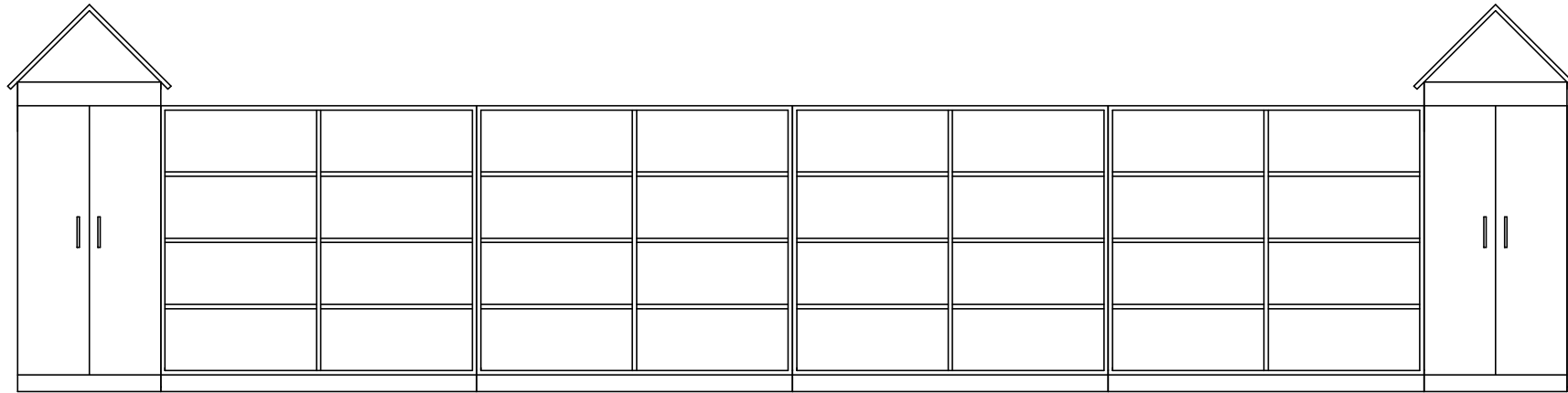
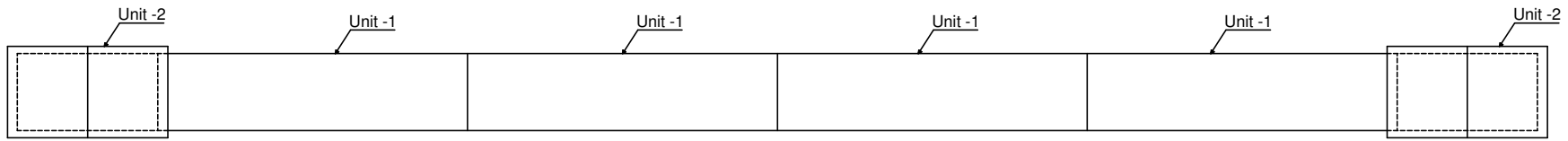

6500.0

1200.0
1625.5

Dimensional Details of Unit -1

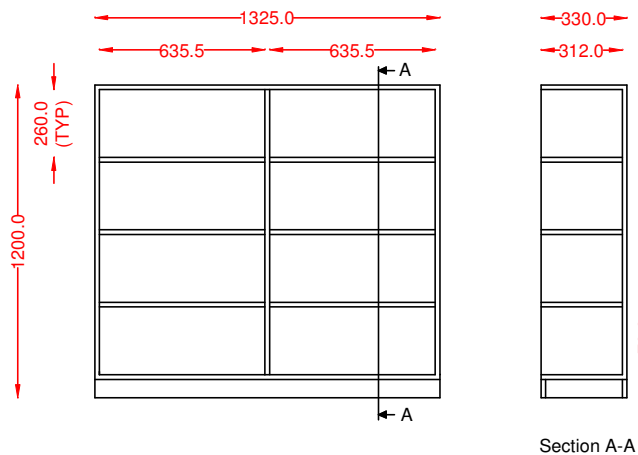

Section A-A

Dimensional Details of Unit -2

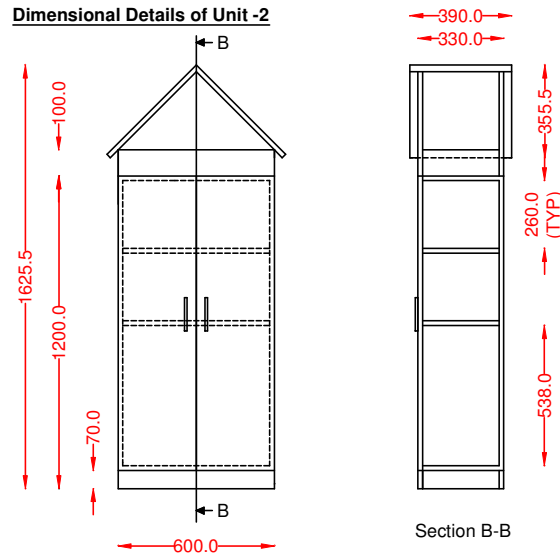

Section B-B

Note :-

1. Material : 18 mm Thick Multiwood (White Colour)
2. Apply primer and Paint only after the completion of fabrication.
3. Avoid projection of fasteners and apply putty before painting.
4. Provide sufficient supports at the time of fabrication.

This drawing is for tendering purpose only.
Subjected to change as per site conditions.

HLL Lifecare Limited <small>(A Government of India Enterprise)</small>		<small>PROJECTS DIVISION CORPORATE & REGD. OFFICE HLL BHAVAN, POOJAPPURA THIRUVANANTHAPURAM KERALA - 695 012</small>	TITLE:- STORAGE CUPBOARD FOR CLASS ROOM FACILITY AT JAWAHAR BALBHAVAN, THIRUVANANTHAPURAM	
DRAWN BY: SARATH KRISHNA	CHECKED BY: ASWATHY M G	DRG NO: HLL-PROJ-EXT-JBT-005	REVISION: 00 DATE :23.11.18	
APPROVED BY: HARIKRISHNAN K P	DATE: 23.11.2018	SITE: KERALA STATE JAWAHAR BALBHAVAN, VELLAYAMBALAM, THIRUVANANTHAPURAM DISTRICT		ISSUED FOR: TENDERING
SCALE: NOT TO SCALE				SHEET NO: 01/01
ALL DIMENSIONS ARE IN MILLIMETER				

This drawing is the Sole Property of M/s.HLL Lifecare Ltd.
The contents of this drawing shall not be reproduced in any
manner or used for other purposes than the intended one.