

Amendment no.2
10th Nov 2017

Sub: Supply of Flap unit & Accessories as per tender specifications and schedule at HLL Lifecare Limited, Peroorkada Factory, Thiruvananthapuram 695 005

Ref no - IFB No. : IFB NO – HLL/PFT/CED/STATIC-TESTING/FLAP UNIT/17 DATED:
27/10/2017

With reference to the above, we here by incorporate the following amendment to the tender documents as detailed below:

Amendment no.2

The last date of date for receipt and opening of bid of the above referred tender has been amended as follows.

- (a) Last date and time of receipt of tender : 16.11.2017,15.00Hrs
- (b) Date and time of opening tender : 16.11.2017, 15.30Hrs
- (c) Specification amendment – Drawing attached

SI No	Original Tender Details	Amended Tender Details
1	Last date and time of receipt of Tender: - 10.11.2017 at 15.00 Hrs. Date and time of opening of Tender : - 10.11.2017 at 15.30 Hrs.	Last date and time of receipt of Tender: - 16.11.201 at 15.00 Hrs. Date and time of opening of Tender : - 16.11.2017 at 15.30 Hrs.

Ref no - IFB No. : IFB NO – HLL/PFT/CED/STATIC-TESTING/FLAP UNIT/17 DATED:
27/10/2017

DEPUTY GENERAL MANAGER (CED)

ITEM NO.	PART NUMBER	DESCRIPTION	QTY.
1	Testing flap assembly	HLL-CED-D5-075-00- Sht No 1/21	1
2	Bottom support of testing flap unit	HLL-CED-D5-075-00- Sht No 2/21	1
3	Mounting plate	HLL-CED-D5-075-00- Sht No 3/21	1
4	Holder for testing flap shaft	HLL-CED-D5-075-00 Sht No 4/21	1
5	Flap fixing shafts	HLL-CED-D5-075-00 Sht No 7/21	6
6	Middle peace	HLL-CED-D5-075-00 Sht No 8/21	1
7	Shaft for flap support fixing	HLL-CED-D5-075-00Sht No 10/21	1
8	M6x15(L)	STD ITEM	4
9	M8x130(L) SHD BOLT	HLL-CED-D5-075-00 Sht No 11/21	1
10	Top support of flap	HLL-CED-D5-075-00 Sht No 12/21	1
11	Bottom support of flap	HLL-CED-D5-075-00 Sht No 13/21	1
12	Flap fixing roller	HLL-CED-D5-075-00 Sht No 14/21	1
13	Coller for testing flap	HLL-CED-D5-075-00 Sht No 15/21	2
14	Flap for RRT	UNDER HLL SCOPE	1
15	M6x10 mm grub screw	STD ITEM	12
16	M10X55	STD ITEM	2
17	M10 FLAT WASHER	STD ITEM	2
18	M10 Spring washer	STD ITEM	2
19	M10 nut	STD ITEM	1
20	M6x30 bolt	STD ITEM	1
21	M6 plane washer	STD ITEM	1
22	M6 spring wاهر	STD ITEM	2
23	Bearing 608-2RS	STD ITEM	1
24	Testing flap stiffner	HLL-CED-D5-075-00 Sht No 16/21	1
25	M6x20	STD ITEM	3
26	M6 nut	STD ITEM	2
27	Bottom spacer	HLL-CED-D5-075-00 Sht No 18/21	1
28	Top spacer	HLL-CED-D5-075-00 Sht No 19/21	1
29	M3 x14 grub screw		1
30	Internal circlip	Suitable for bottom support of flap	1
31	D series brush holder with brush	Std item (D series brush holder with brush)	2
38	Top shaft for brush holder	HLL-CED-D5-075-00 Sht No 20/21	1
39	Bottom shaft for brush holder	HLL-CED-D5-075-00 Sht No 21/21	1
40	M8 Nut		2

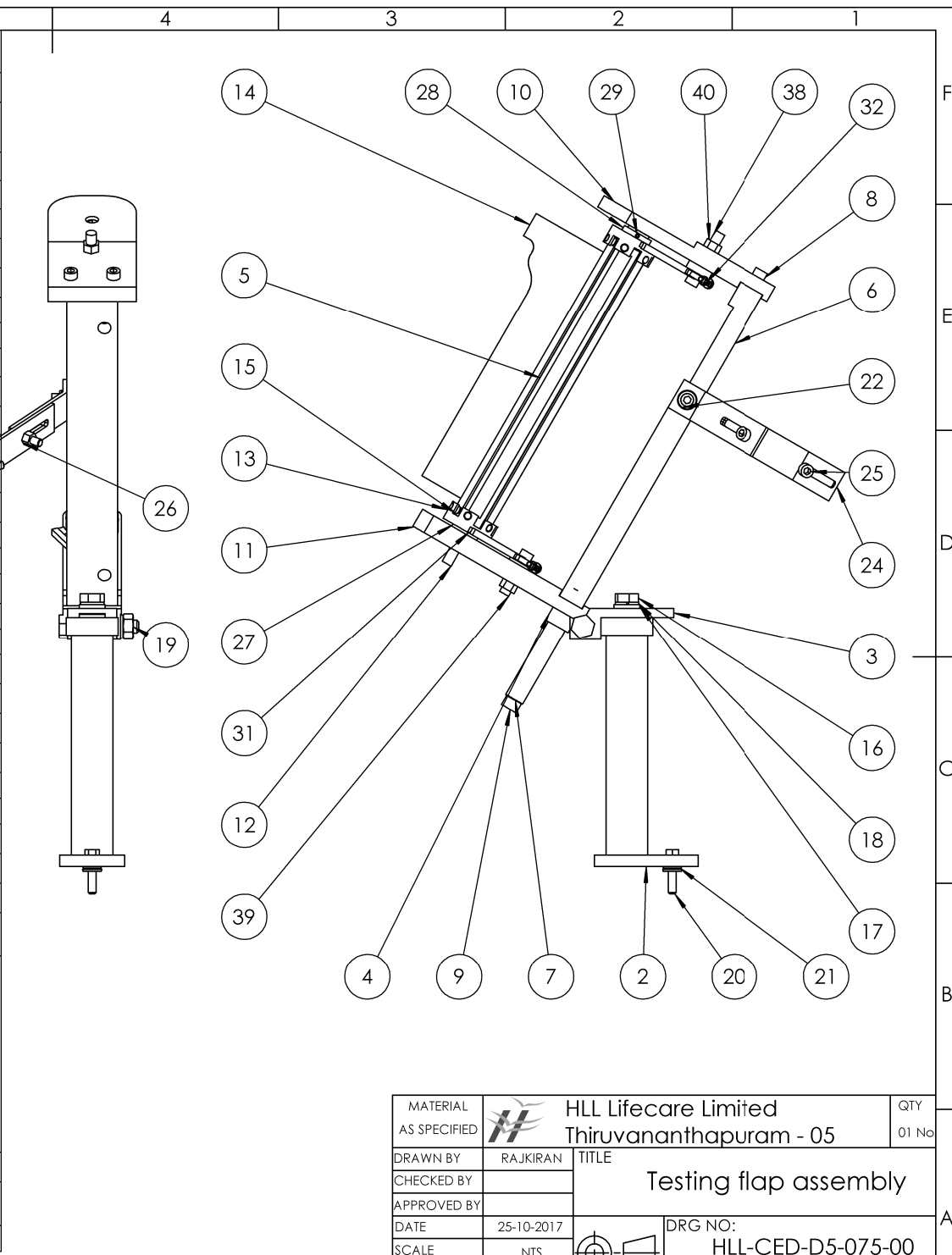

MATERIAL AS SPECIFIED		HLL Lifecare Limited Thiruvananthapuram - 05	QTY 01 No
DRAWN BY	RAJKIRAN	TITLE Testing flap assembly	
CHECKED BY		DRG NO: HLL-CED-D5-075-00	
APPROVED BY		SHEET NO : 01/21	
DATE	25-10-2017	REV: ----- DATE: -----	
SCALE	NTS	ALL DIMENSIONS ARE IN MM	

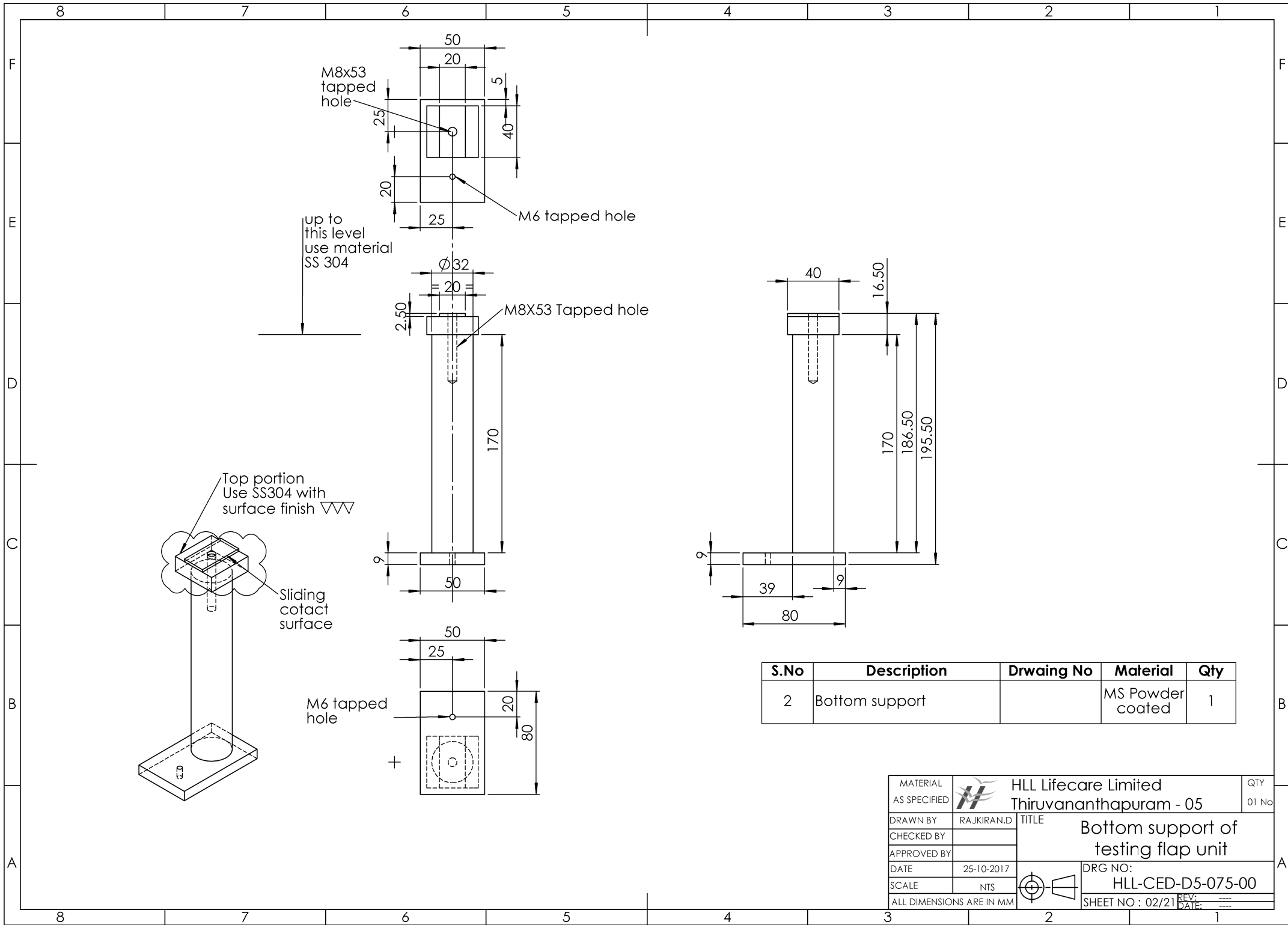

S.No	Description	Drwaing No	Material	Qty
2	Bottom support		MS Powder coated	1

MATERIAL AS SPECIFIED	 HLL Lifecare Limited Thiruvananthapuram - 05	QTY 01 No
DRAWN BY	RAJKIRAN.D	TITLE Bottom support of testing flap unit
CHECKED BY		DRG NO: HLL-CED-D5-075-00
APPROVED BY		SHEET NO : 02/21
DATE	25-10-2017	REV: _____ DATE: _____
SCALE	NTS	
ALL DIMENSIONS ARE IN MM		

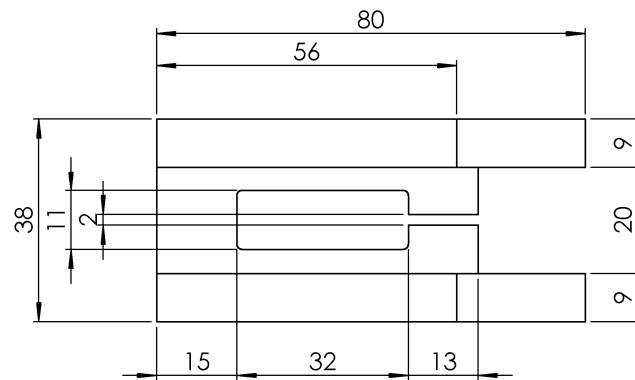
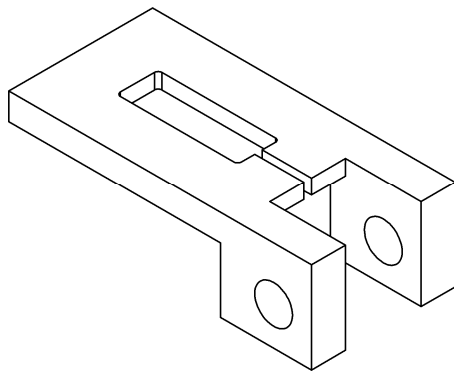
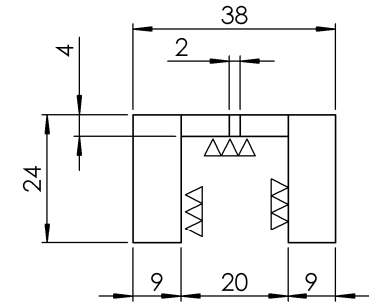
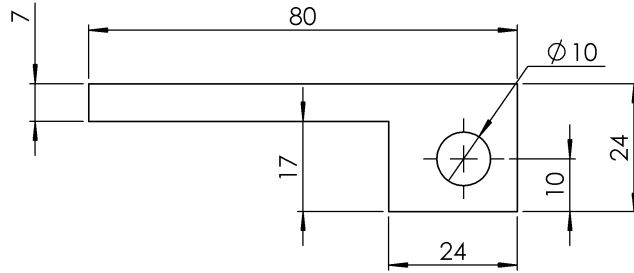
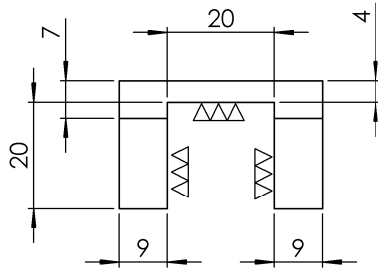
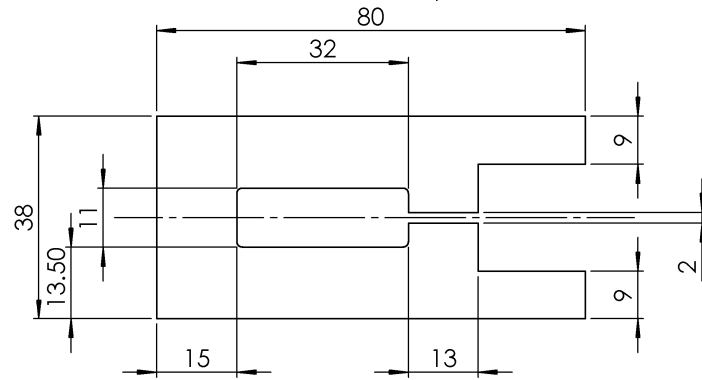

S.No	Description	Drawing No	Material	Qty
3	Mounting plate		SS 304	1

MATERIAL AS SPECIFIED	 HLL Lifecare Limited Thiruvananthapuram - 05	QTY 01 No
DRAWN BY	RAJKIRAN	TITLE MOUNTING PLATE
CHECKED BY		
APPROVED BY		DRG NO: HLL-CED-D5-075-00
DATE	25-10-2017	
SCALE	NTS	SHEET NO : 03/21 REV: --- DATE: ---
ALL DIMENSIONS ARE IN MM		

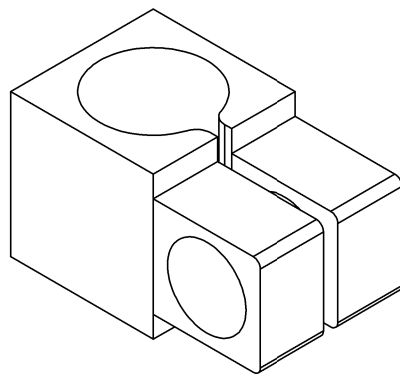
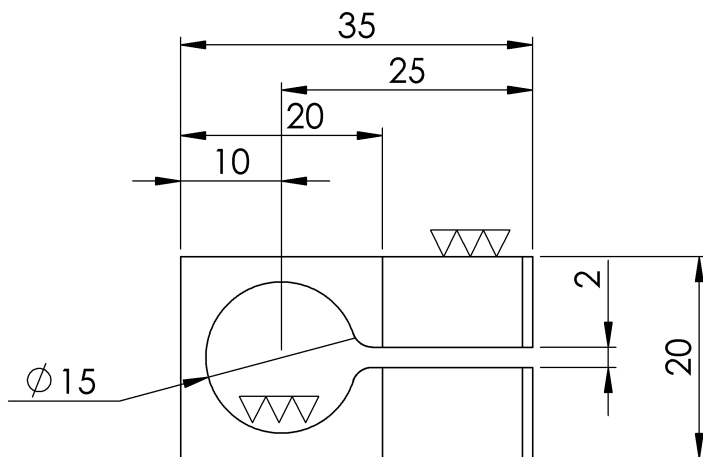
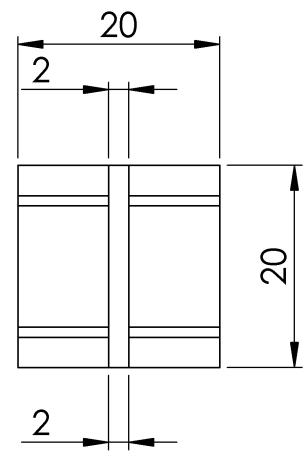
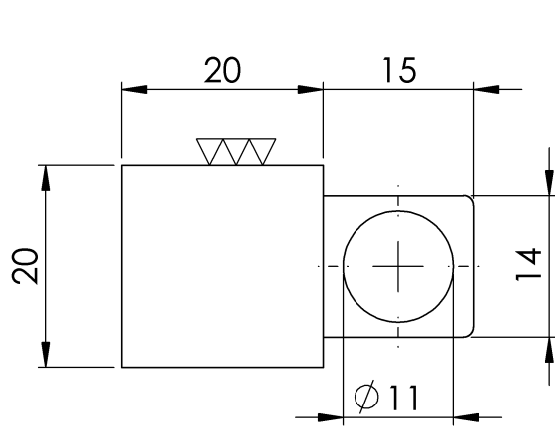

S.No	Description	Drawing No	Material	Qty
4	Holder for testing flap shaft		SS 304	1

Weight of the Component : g (approx.)

HLL Lifecare Limited
Thiruvananthapuram - 05

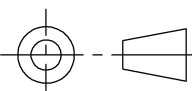
MATERIAL AS SPECIFIED		Thiruvananthapuram - 05		QTY 01 No
DRAWN BY		RAJKIRAN	TITLE Holder for testing flap shaft	
CHECKED BY				
APPROVED BY				
DATE	25-10-2017	DRG NO:	HLL-CED-D5-075-00	
SCALE	NTS	SHEET NO:	04/21	
ALL DIMENSIONS ARE IN MM		REV:		
		DATE:		

4

3

2

1

F

F

E

E

D

D

C

C

B

B

A

A

Weight of the Component : g (approx.)

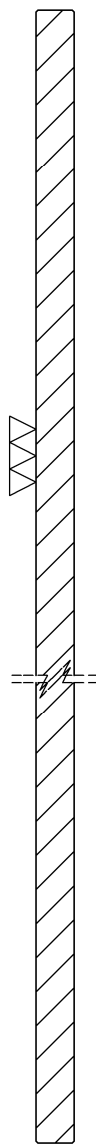
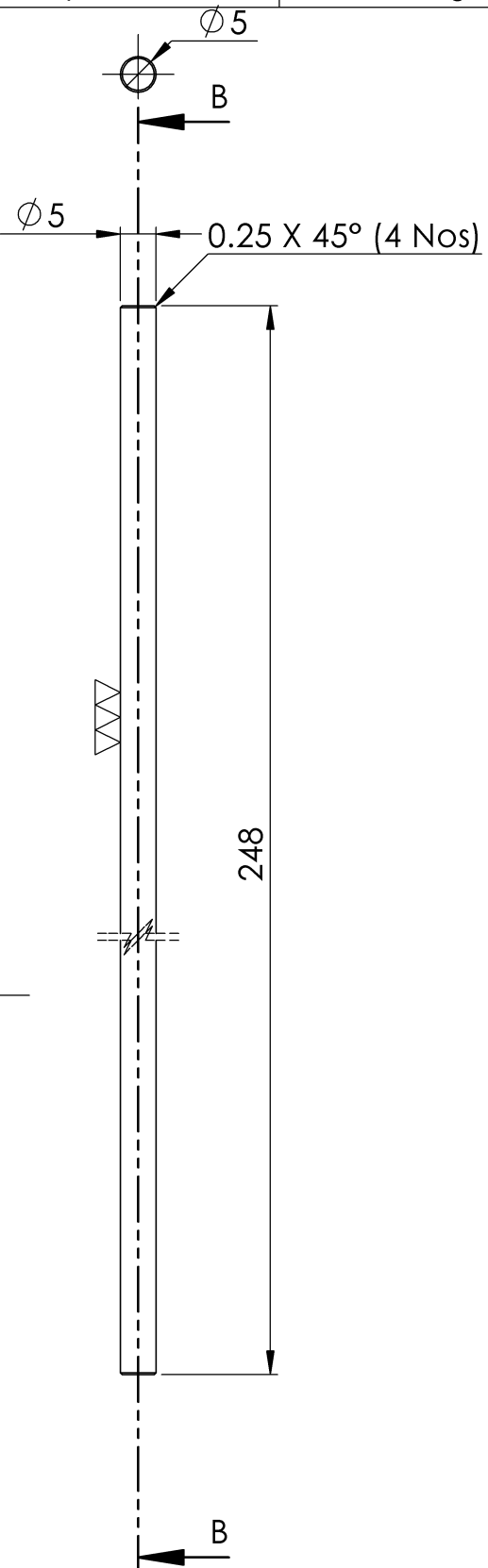

SECTION B-B
SCALE 1 : 1

S.No	Description	Drawing No	Material	Qty
5	Flap fixing shafts		SS 304	1

MATERIAL
AS SPECIFIED



HLL Lifecare Limited
Thiruvananthapuram - 05

QTY
01 No

DRAWN BY: RAJKIRAN
 CHECKED BY:
 APPROVED BY:

TITLE
Flap fixing shafts

DATE: 17.01.2017
 SCALE: NTS
 ALL DIMENSIONS ARE IN MM

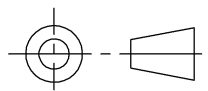

DRG NO: HLL-CED-D5-075-00
 SHEET NO: 07/21
 REV: _____
 DATE: _____

4

3

2

1

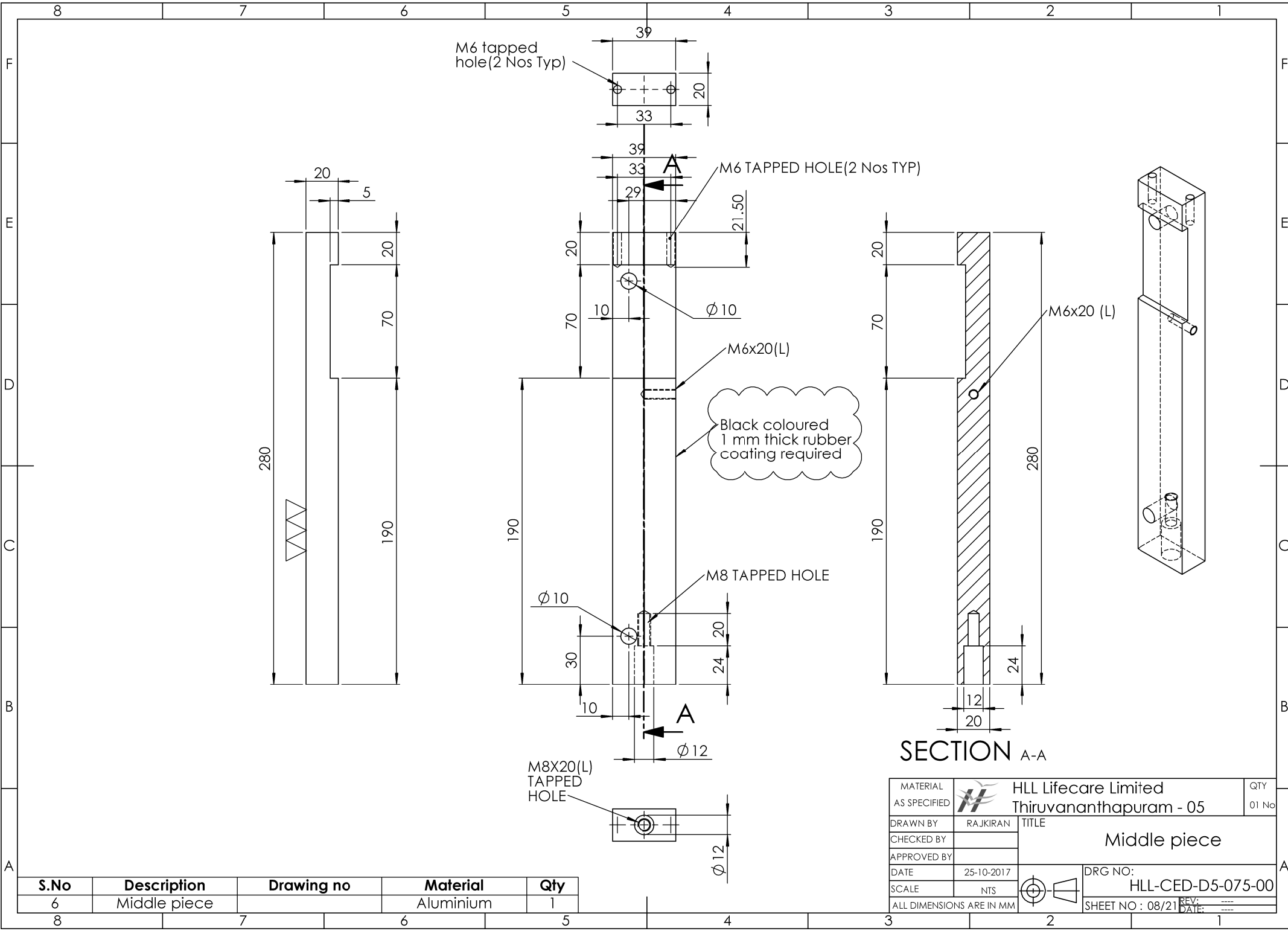

S.No	Description	Drawing no	Material	Qty
6	Middle piece		Aluminium	1

MATERIAL AS SPECIFIED	HLL Lifecare Limited Thiruvananthapuram - 05	QTY 01 No
DRAWN BY	RAJKIRAN	TITLE Middle piece
CHECKED BY		
APPROVED BY		
DATE	25-10-2017	DRG NO: HLL-CED-D5-075-00
SCALE	NTS	SHEET NO : 08/21
ALL DIMENSIONS ARE IN MM		REV: DATE:

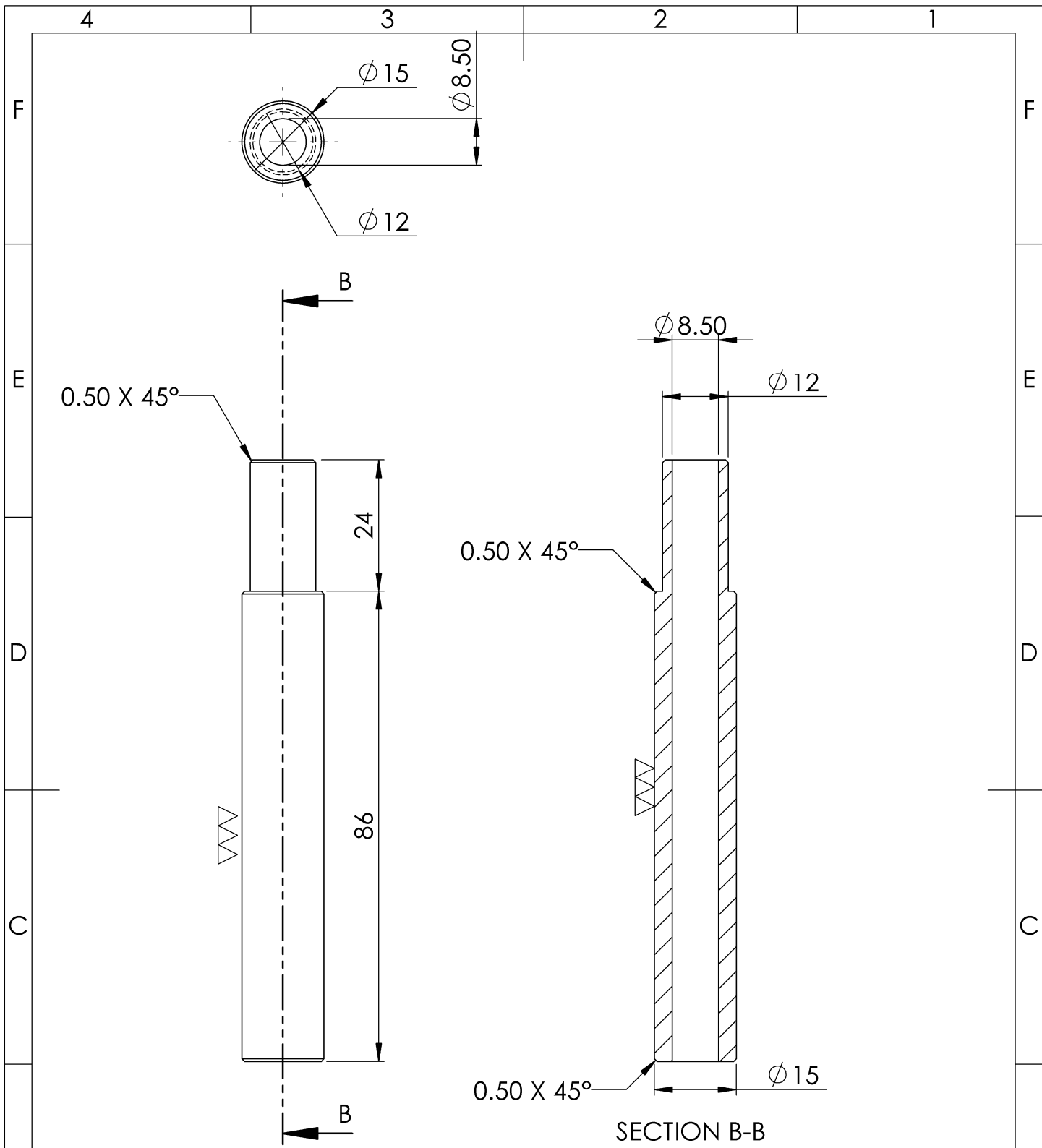

S.No	Description	Drawing No	Material	Qty
10	Shaft for shaft support fixing	HLL-CED-D5-075-00	SS 304	1

Weight of the Component : g (approx.)

MATERIAL AS SPECIFIED		HLL Lifecare Limited Thiruvananthapuram - 05	QTY 01 No
DRAWN BY	RAJKIRAN	TITLE Shaft for flap support fixing	
CHECKED BY			
APPROVED BY			
DATE	17.01.2017	DRG NO:	HLL-CED-D5-075-00
SCALE	NTS		
ALL DIMENSIONS ARE IN MM		SHEET NO: 10/21	REV: DATE:

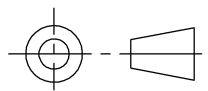

4

3

2

1

F

F

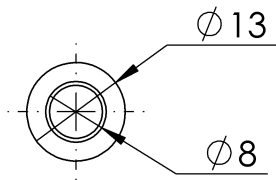

E

E

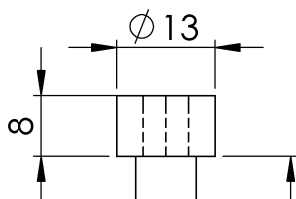

D

D

100

C

C

M8 THREADED REGION

30

B

B

Weight of the Component
: g (approx.)

ITEM NO.	PART NUMBER	DESCRIPTION	QTY.
9	M8x130(L) SHD BOLT	Material- SS 304	1

MATERIAL
AS SPECIFIED



HLL Lifecare Limited
Thiruvananthapuram - 05

QTY
01 No

DRAWN BY RAJKIRAN

TITLE

CHECKED BY

M8X130(L) SHD BOLT FOR TESTING FLAP

APPROVED BY

DATE 17.01.2017

DRG NO: HLL-CED-D5-075-00

SCALE NTS

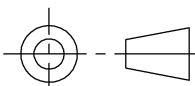

SHEET NO: 11/21

REV:
DATE:

ALL DIMENSIONS ARE IN MM

4

3

2

1

A

A

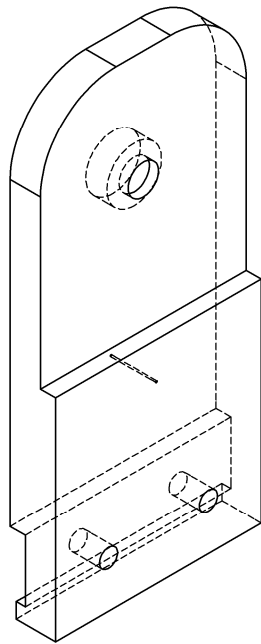

M6 through hole (2 Nos)

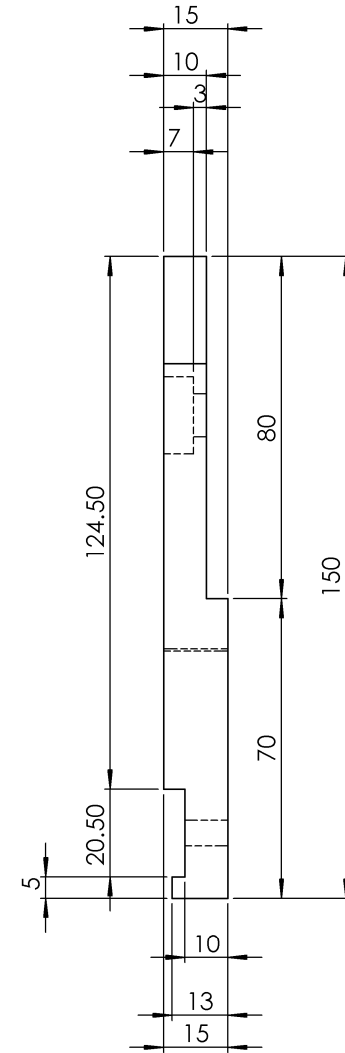
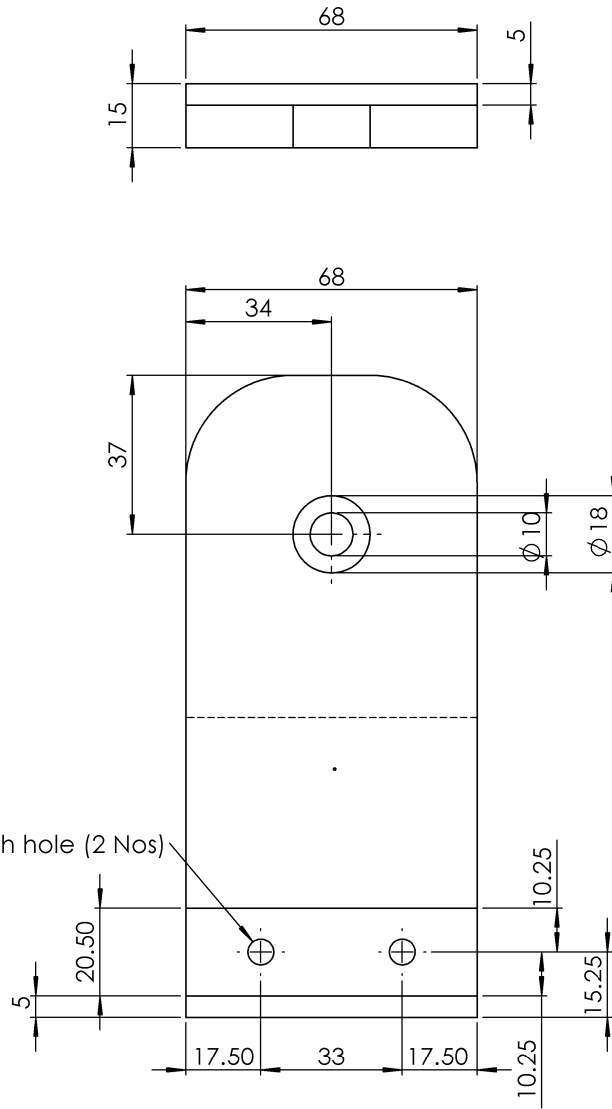

S.No	Description	Drawing No	Material	Qty
10	Top support of flap		hylem	1

MATERIAL AS SPECIFIED		HLL Lifecare Limited Thiruvananthapuram - 05	QTY 01 No
DRAWN BY	RAJKIRAN	TITLE Top support of flap	
CHECKED BY			
APPROVED BY			
DATE	17.01.2017	DRG NO: HLL-CED-D5-075-00	
SCALE	NTS	SHEET NO : 12/21	
ALL DIMENSIONS ARE IN MM		REV: _____ DATE: _____	

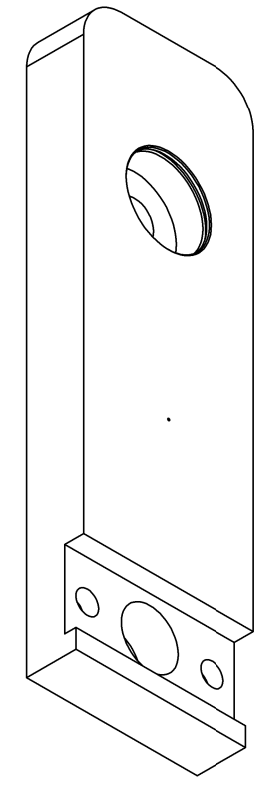
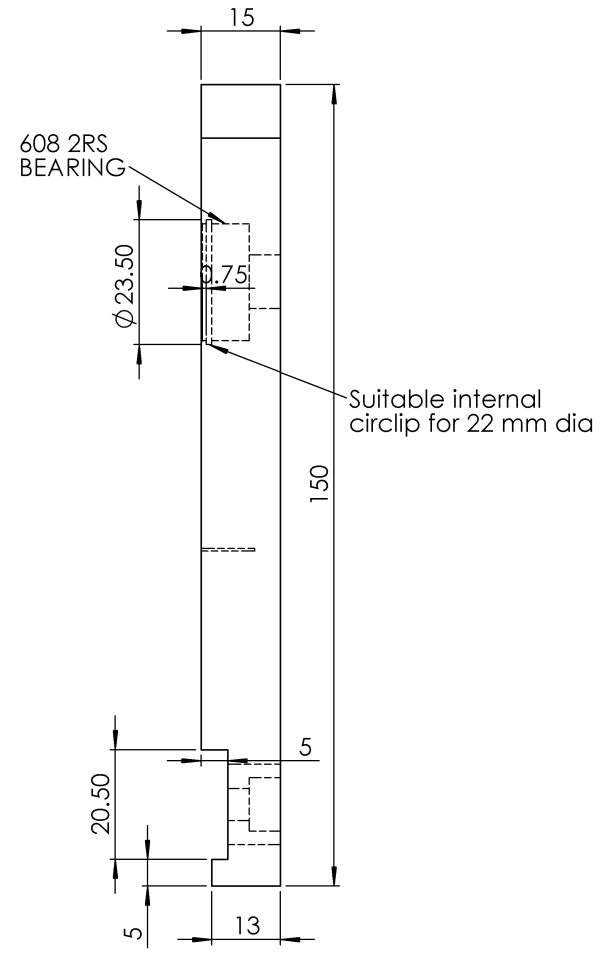
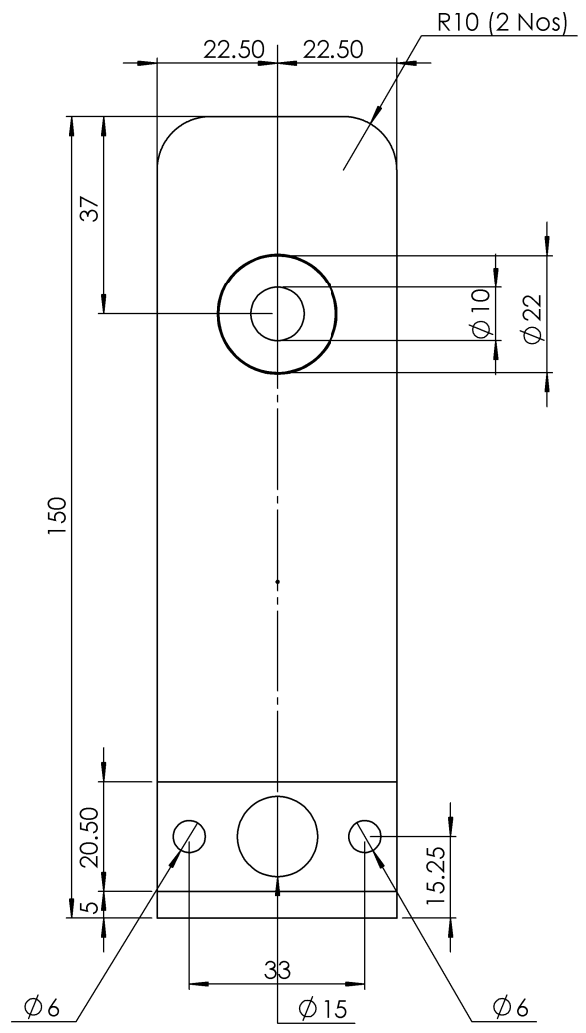

S.No	Description	Drawing No	Material	Qty
11	Bottom support of flap		Hylem	1

MATERIAL AS SPECIFIED	 HLL Lifecare Limited Thiruvananthapuram - 05	QTY 01 No
DRAWN BY	RAJKIRAN	TITLE Bottom support of flap
CHECKED BY		
APPROVED BY		
DATE	17.01.2017	DRG NO: HLL-CED-D5-075-00
SCALE	NTS	SHEET NO : 13/21
ALL DIMENSIONS ARE IN MM		REV: _____ DATE: _____

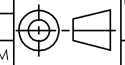

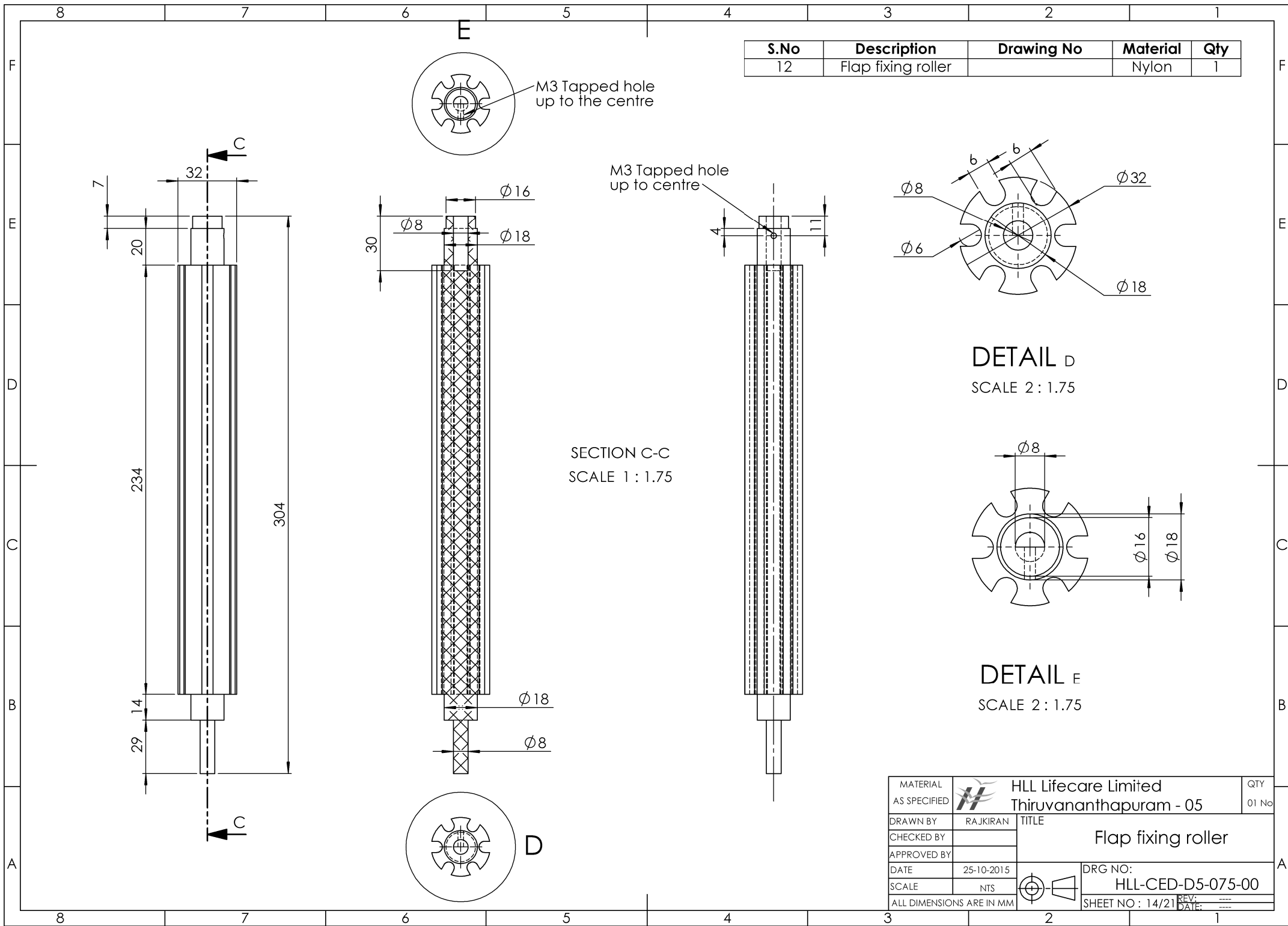

S.No	Description	Drawing No	Material	Qty
12	Flap fixing roller		Nylon	1



M3 Tapped hole up to the centre

M3 Tapped hole up to centre

DETAIL D
SCALE 2 : 1.75

SECTION C-C
SCALE 1 : 1.75

DETAIL E
SCALE 2 : 1.75

MATERIAL AS SPECIFIED	 HLL Lifecare Limited Thiruvananthapuram - 05	QTY
DRAWN BY		01 No
CHECKED BY	Flap fixing roller	
APPROVED BY		
DATE		25-10-2015
SCALE	NTS	
ALL DIMENSIONS ARE IN MM		 DRG NO: HLL-CED-D5-075-00
		SHEET NO : 14/21 REV: _____ DATE: _____

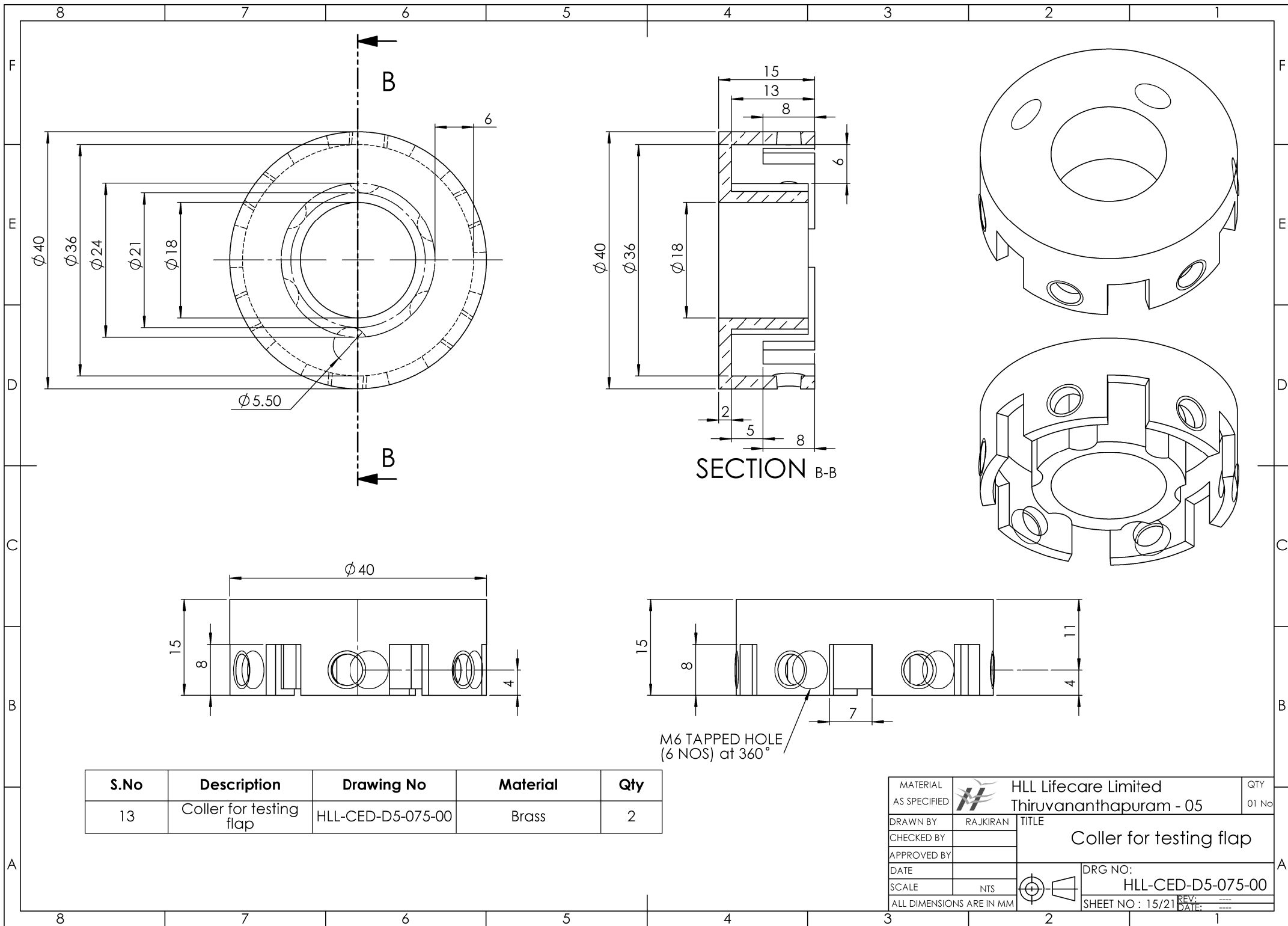

S.No	Description	Drawing No	Material	Qty
13	Collar for testing flap	HLL-CED-D5-075-00	Brass	2

MATERIAL AS SPECIFIED		HLL Lifecare Limited Thiruvananthapuram - 05	QTY 01 No
DRAWN BY	RAJKIRAN	TITLE Collar for testing flap	
CHECKED BY			
APPROVED BY			
DATE		DRG NO: HLL-CED-D5-075-00	
SCALE	NTS	SHEET NO : 15/21	
ALL DIMENSIONS ARE IN MM		REV: _____ DATE: _____	

4

3

2

1

F

F

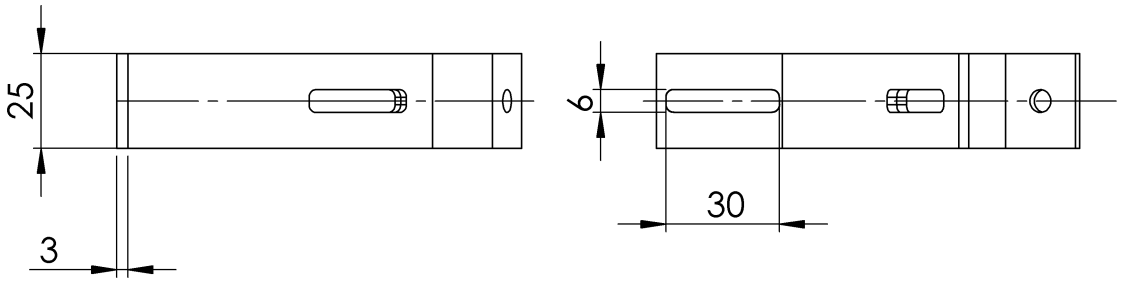

E

E

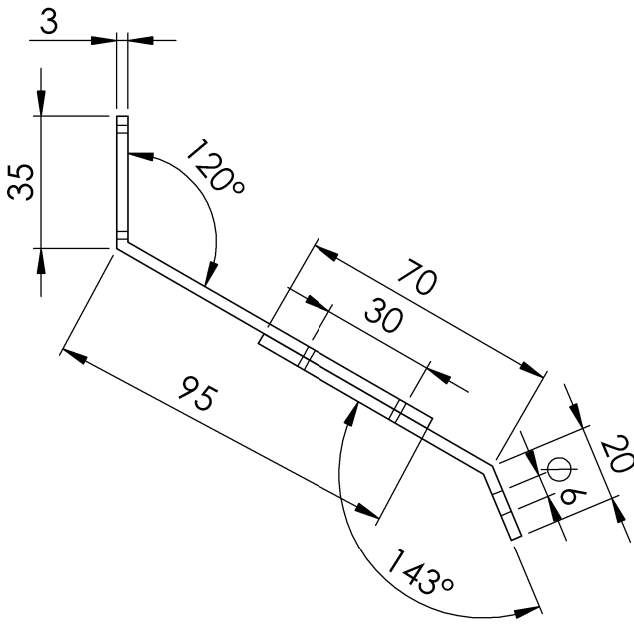

D

D

C

C

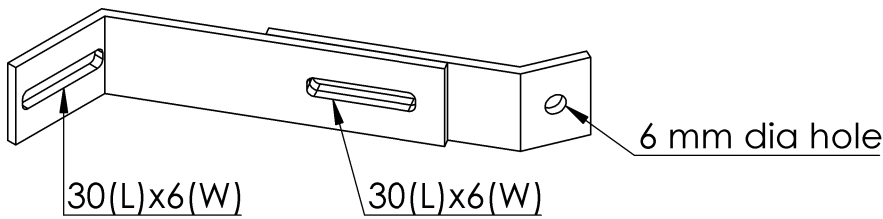

S.No	Description	Drawing No	Material	Qty
24	Testing flap stiffner		SS 304	1

B

B

Weight of the Component : g (approx.)

A

A

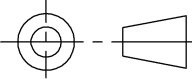
MATERIAL AS SPECIFIED	 HLL Lifecare Limited Thiruvananthapuram - 05	QTY
		01 No
DRAWN BY	RAJKIRAN	TITLE Testing flap stiffner
CHECKED BY		
APPROVED BY		
DATE	26-10-2017	DRG NO: HLL-CED-D5-075-00
SCALE	NTS	SHEET NO: 16/21
ALL DIMENSIONS ARE IN MM		REV: DATE:

4

3

2

1

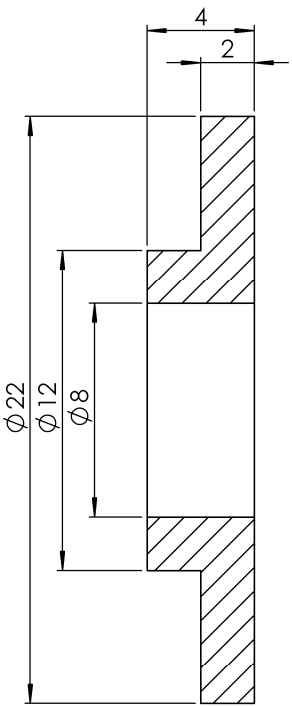
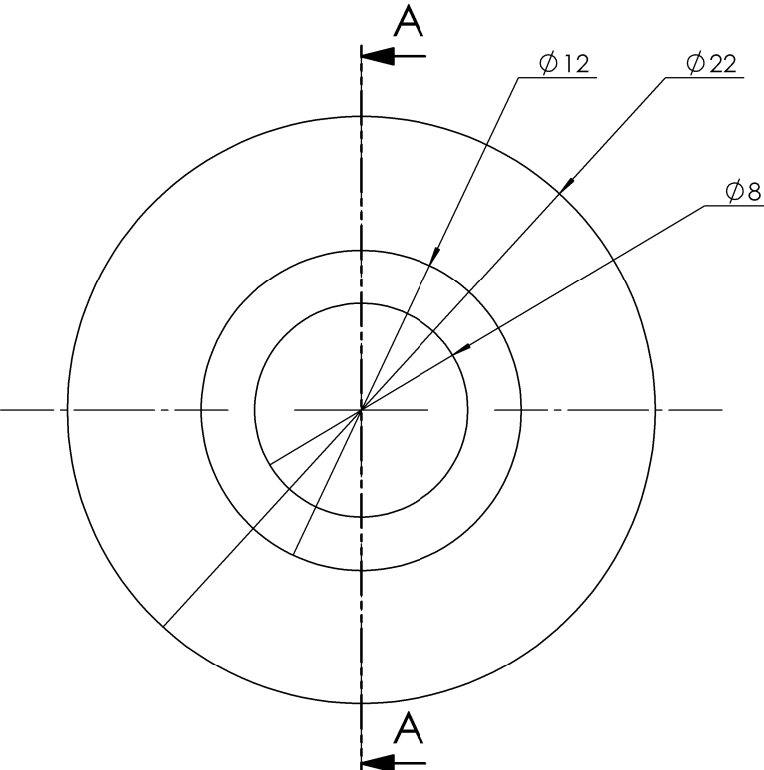
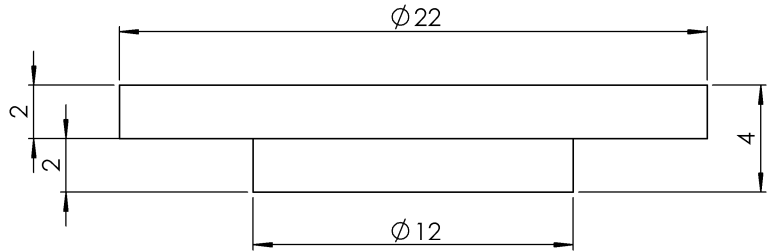
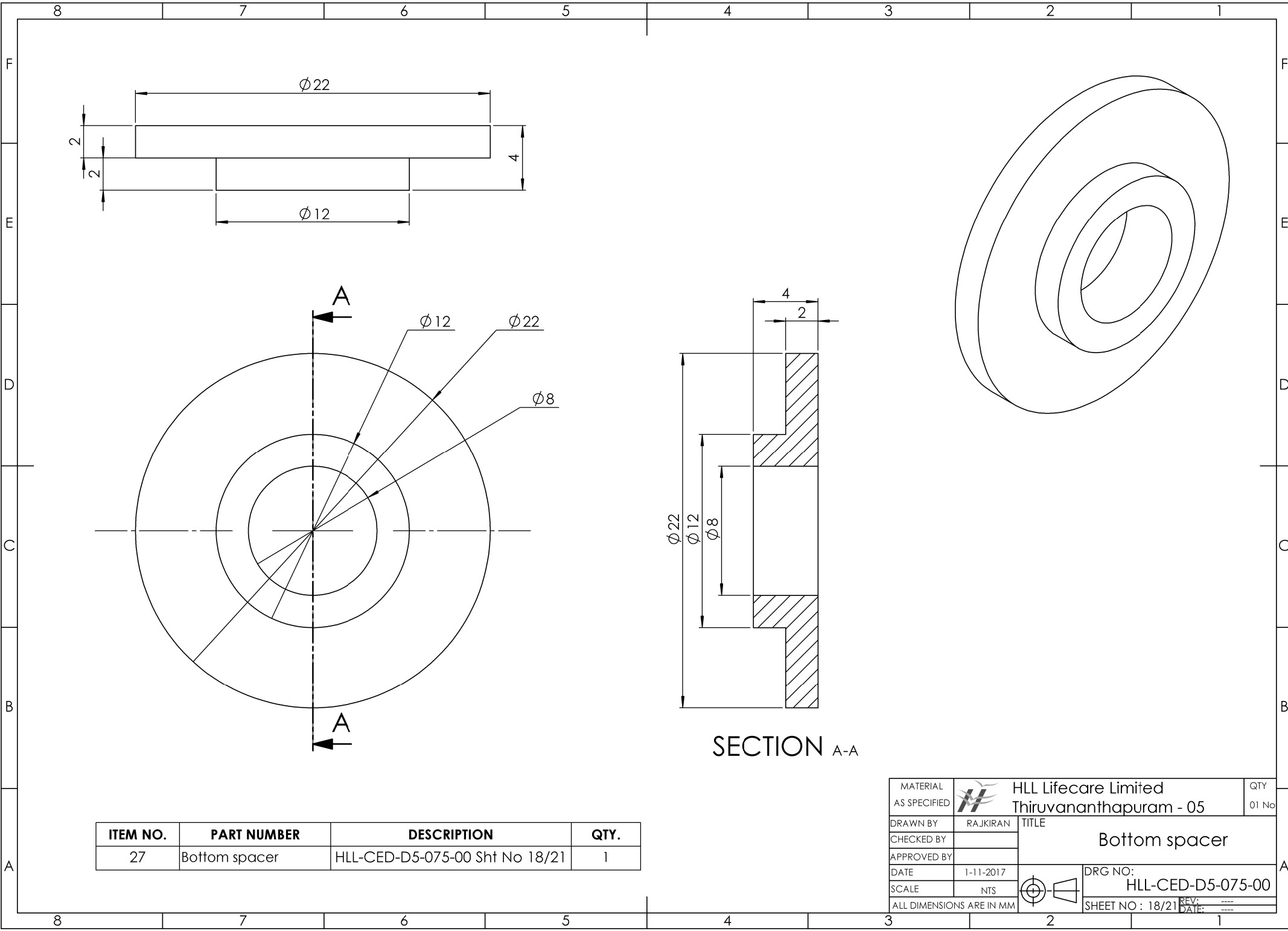

SECTION A-A

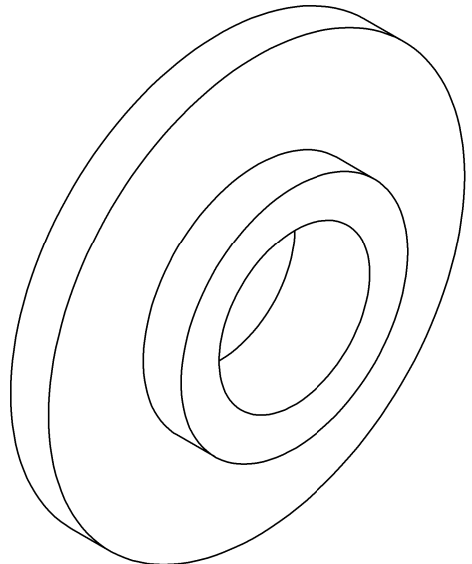

ITEM NO.	PART NUMBER	DESCRIPTION	QTY.
27	Bottom spacer	HLL-CED-D5-075-00 Sht No 18/21	1

MATERIAL AS SPECIFIED	 HLL Lifecare Limited Thiruvananthapuram - 05	QTY 01 No
DRAWN BY	RAJKIRAN	TITLE Bottom spacer
CHECKED BY		
APPROVED BY		
DATE	1-11-2017	DRG NO: HLL-CED-D5-075-00
SCALE	NTS	SHEET NO : 18/21
ALL DIMENSIONS ARE IN MM		REV: _____ DATE: _____

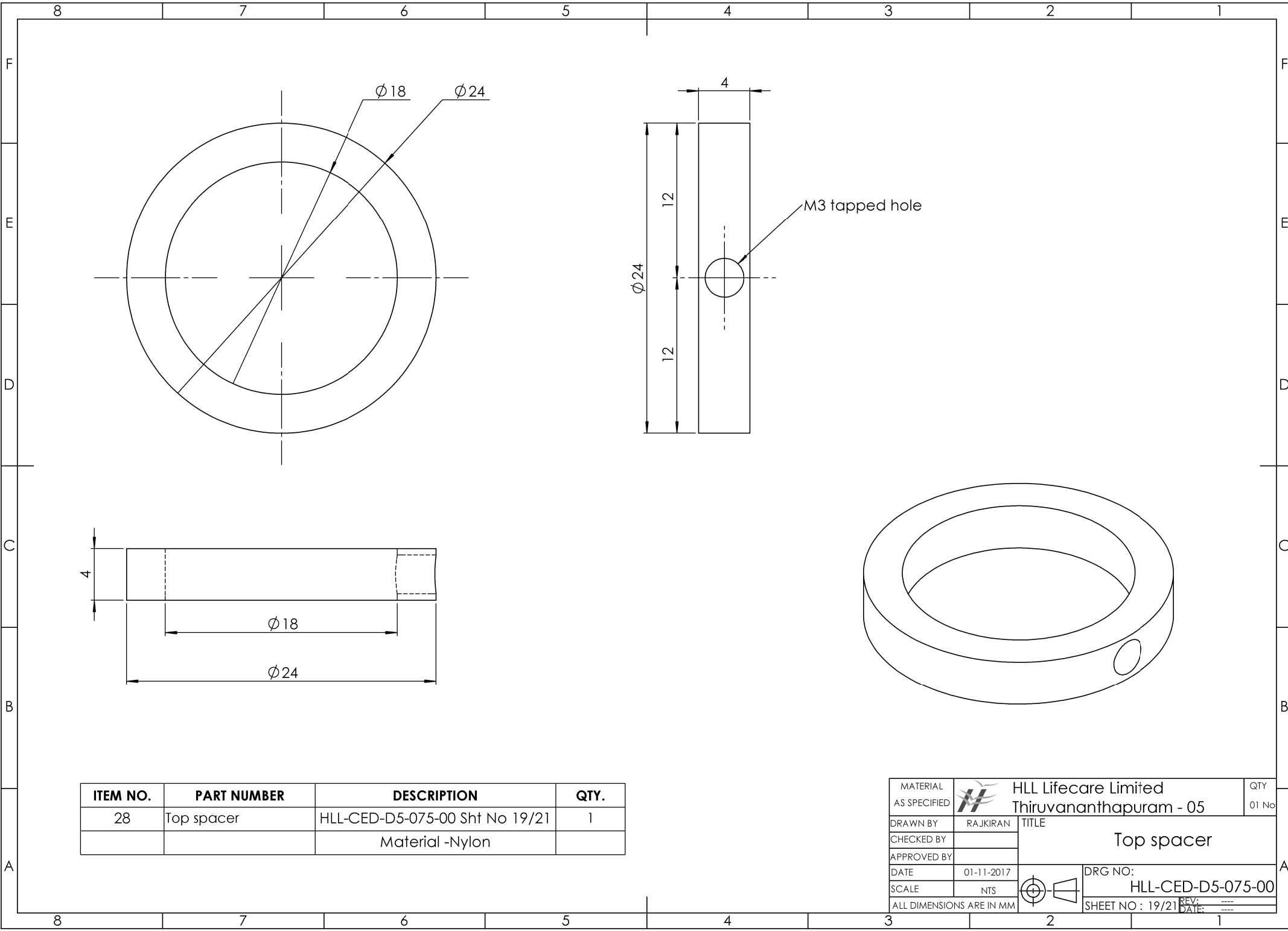

ITEM NO.	PART NUMBER	DESCRIPTION	QTY.
28	Top spacer	HLL-CED-D5-075-00 Sht No 19/21	1
		Material -Nylon	

MATERIAL AS SPECIFIED	 HLL Lifecare Limited Thiruvananthapuram - 05	QTY 01 No
DRAWN BY	RAJKIRAN	TITLE Top spacer
CHECKED BY		
APPROVED BY		DRG NO: HLL-CED-D5-075-00
DATE	01-11-2017	
SCALE	NTS	SHEET NO : 19/21 REV: ---- DATE: ----
ALL DIMENSIONS ARE IN MM		

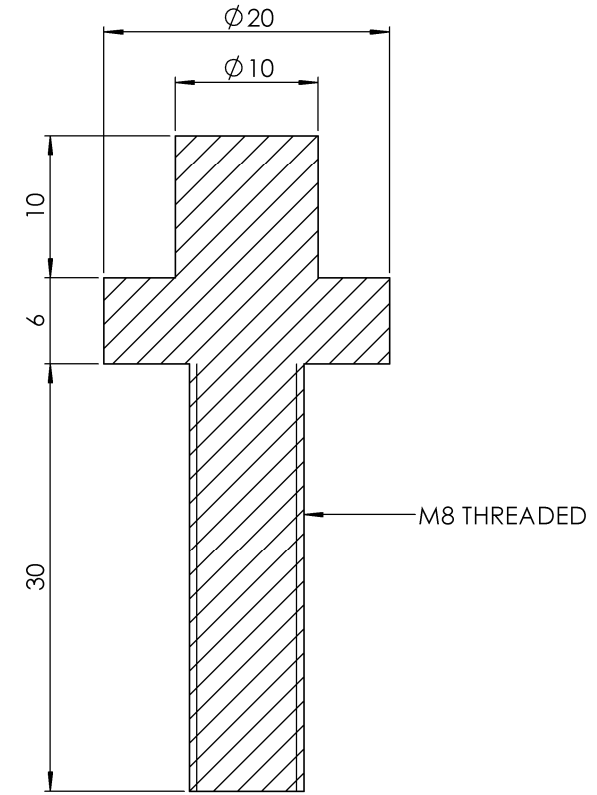
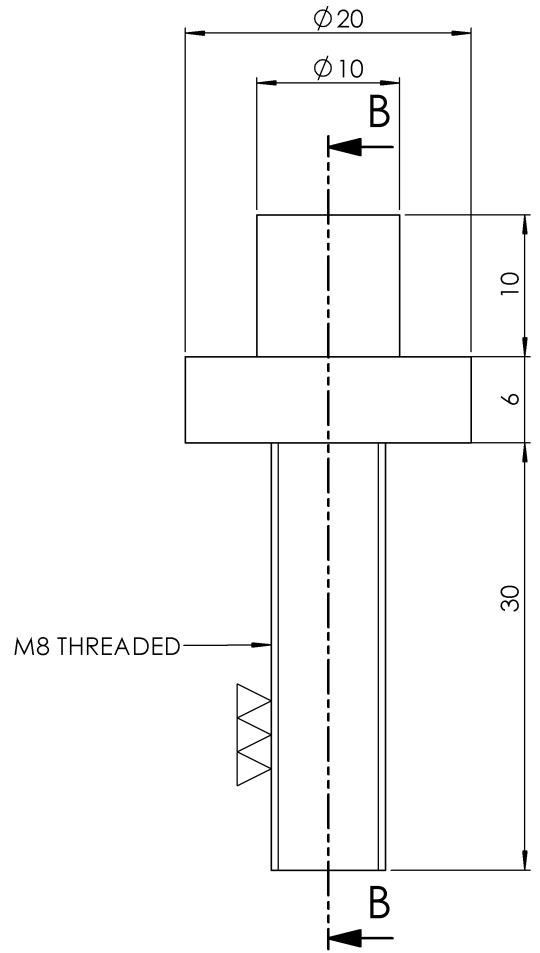

SECTION B-B
SCALE 2 : 0.75

ITEM NO.	PART NUMBER	DESCRIPTION	QTY.
38	Top shaft for brush holder	HLL-CED-D5-075-00	1

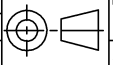
MATERIAL BRASS	 HLL Lifecare Limited Thiruvananthapuram - 05	QTY 01 No
DRAWN BY RAJKIRAN		TITLE Top shaft for brush holder
CHECKED BY		
APPROVED BY		
DATE 08-11-2017	DRG NO: HLL-CED-D5-075-00	
SCALE NTS		
ALL DIMENSIONS ARE IN MM		SHEET NO : 20/21 REV: ---- DATE: ----

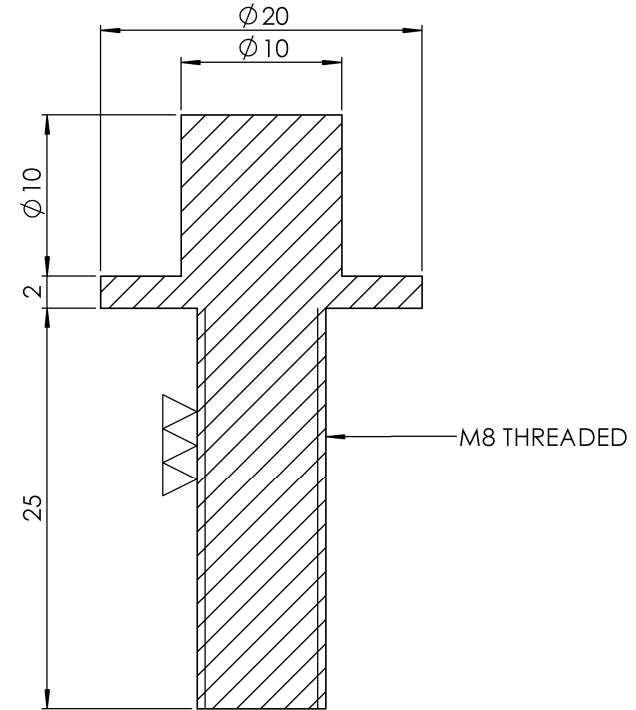
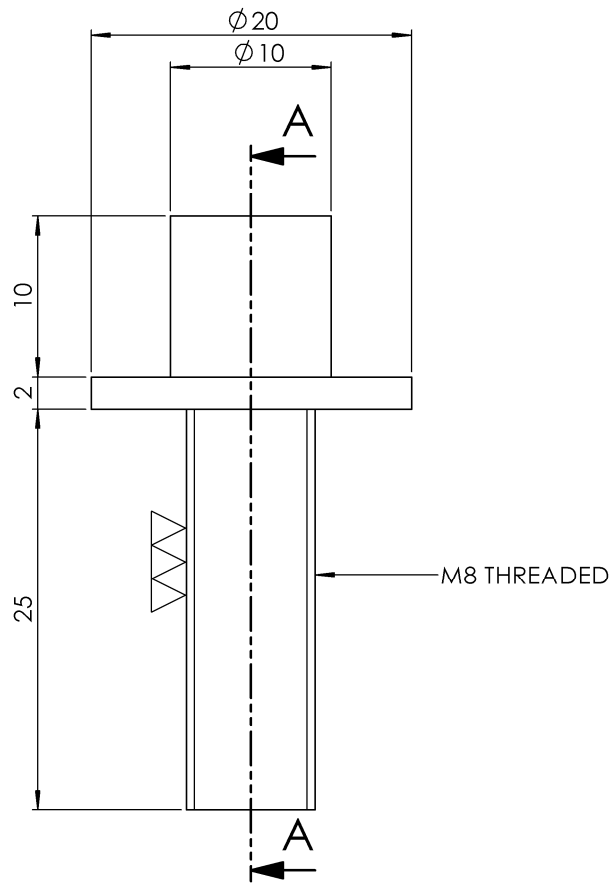



SECTION A-A
SCALE 3 : 1

ITEM NO.	PART NUMBER	DESCRIPTION	QTY.
39	Bottom shaft for brush holder	HLL-CED-D5-075-00	1

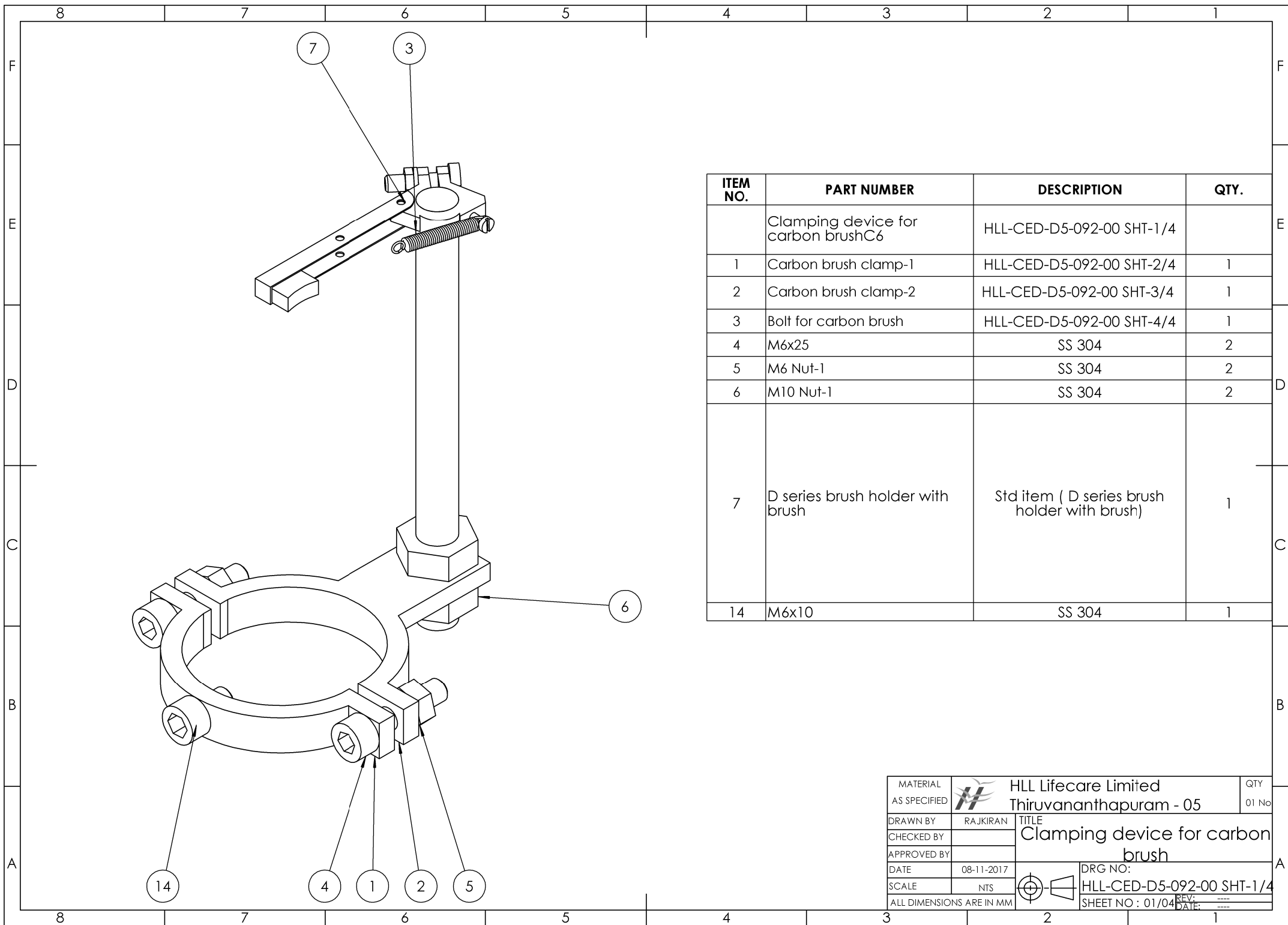
MATERIAL BRASS		HLL Lifecare Limited Thiruvananthapuram - 05	QTY 01 No
DRAWN BY RAJKIRAN	TITLE Bottom shaft for brush holder		
CHECKED BY			
APPROVED BY			
DATE 08-11-2017	DRG NO: HLL-CED-D5-075-00		
SCALE NTS	SHEET NO : 21/21	REV: -----	DATE: -----
ALL DIMENSIONS ARE IN MM			



ITEM NO.	PART NUMBER	DESCRIPTION	QTY.
	Clamping device for carbon brushC6	HLL-CED-D5-092-00 SHT-1/4	
1	Carbon brush clamp-1	HLL-CED-D5-092-00 SHT-2/4	1
2	Carbon brush clamp-2	HLL-CED-D5-092-00 SHT-3/4	1
3	Bolt for carbon brush	HLL-CED-D5-092-00 SHT-4/4	1
4	M6x25	SS 304	2
5	M6 Nut-1	SS 304	2
6	M10 Nut-1	SS 304	2
7	D series brush holder with brush	Std item (D series brush holder with brush)	1
14	M6x10	SS 304	1

MATERIAL AS SPECIFIED	 HLL Lifecare Limited Thiruvananthapuram - 05	QTY
DRAWN BY		RAJKIRAN
CHECKED BY		TITLE
APPROVED BY		Clamping device for carbon brush
DATE	08-11-2017	DRG NO:
SCALE	NTS	HLL-CED-D5-092-00 SHT-1/4
ALL DIMENSIONS ARE IN MM		  SHEET NO : 01/04 REV: _____ DATE: _____

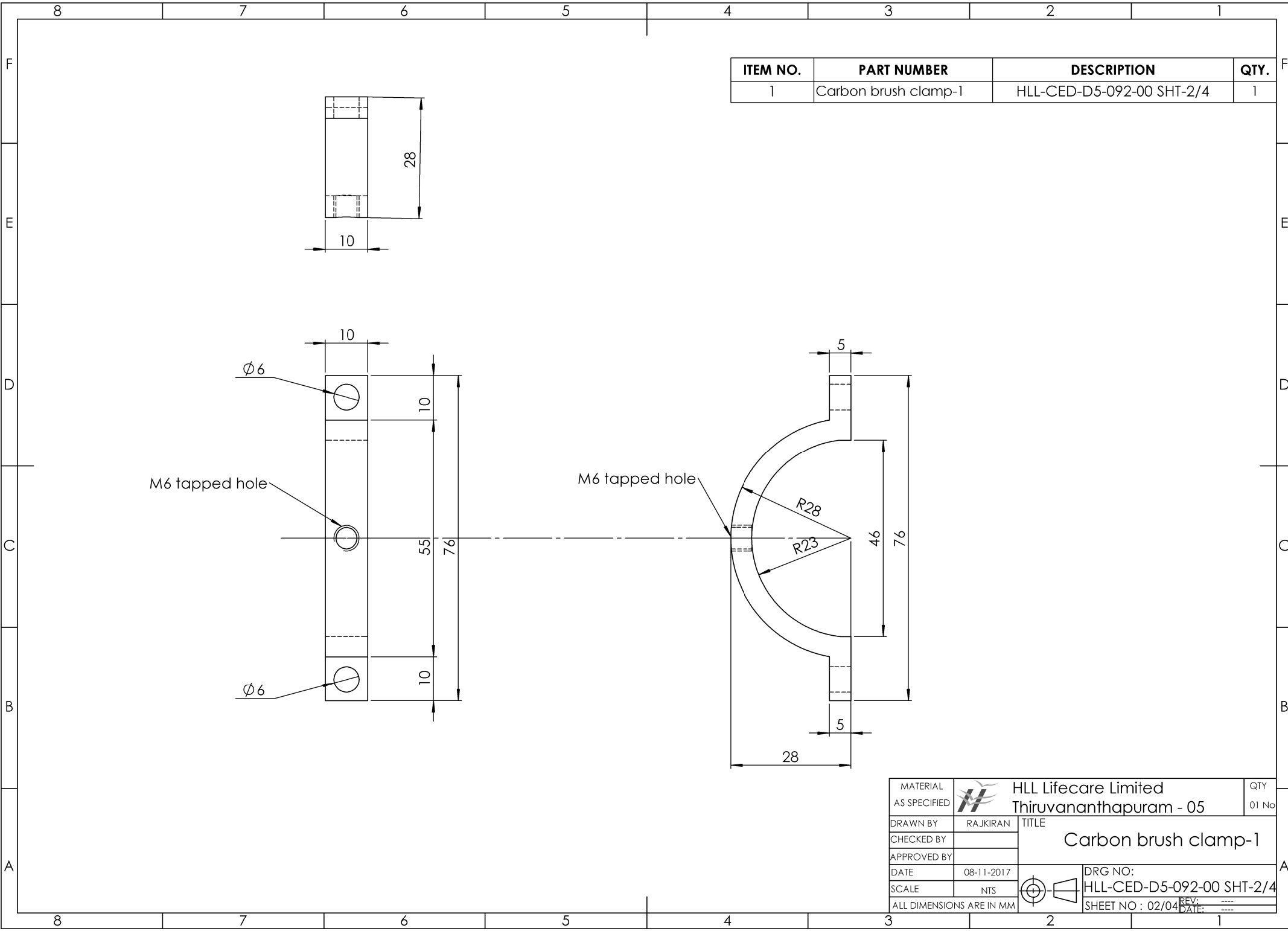

ITEM NO.	PART NUMBER	DESCRIPTION	QTY.
1	Carbon brush clamp-1	HLL-CED-D5-092-00 SHT-2/4	1

MATERIAL AS SPECIFIED	 HLL Lifecare Limited Thiruvananthapuram - 05	QTY 01 No
DRAWN BY	RAJKIRAN	TITLE Carbon brush clamp-1
CHECKED BY		
APPROVED BY		
DATE	08-11-2017	DRG NO: HLL-CED-D5-092-00 SHT-2/4
SCALE	NTS	SHEET NO : 02/04
ALL DIMENSIONS ARE IN MM		REV: _____ DATE: _____

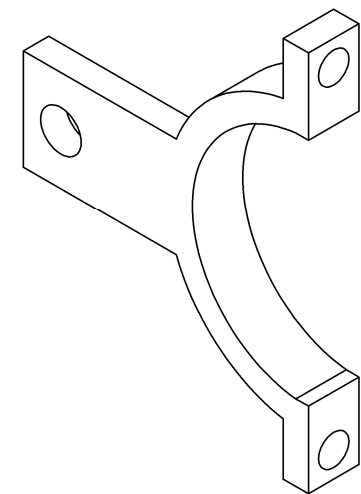
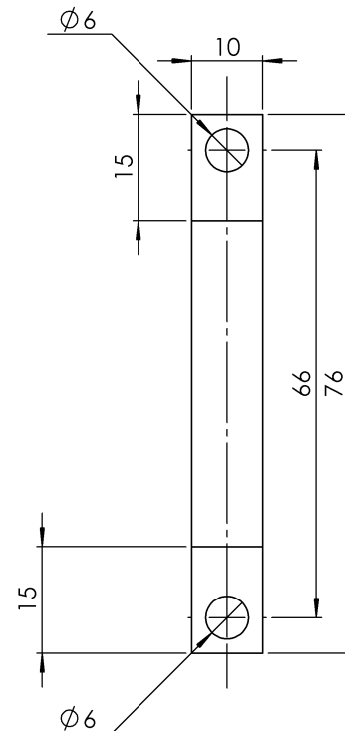
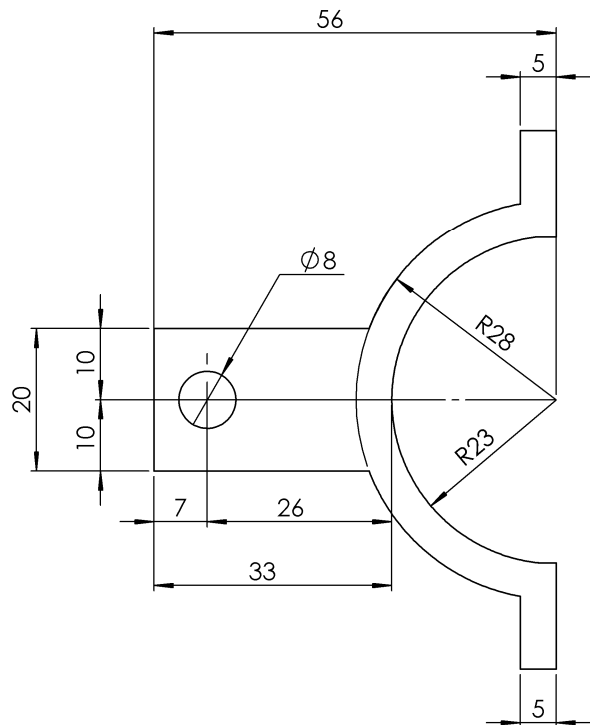
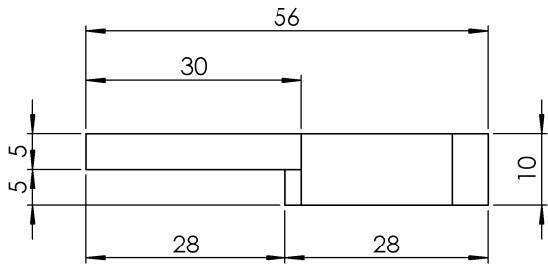

ITEM NO.	PART NUMBER	DESCRIPTION	QTY.
2	Carbon brush clamp-2	HLL-CED-D5-092-00 SHT-3/4	1

MATERIAL AS SPECIFIED	 HLL Lifecare Limited Thiruvananthapuram - 05	QTY 01 No
DRAWN BY	RAJKIRAN	TITLE
CHECKED BY		Carbon brush clamp-2
APPROVED BY		
DATE	08-11-2017	DRG NO:
SCALE	NTS	HLL-CED-D5-092-00 SHT-3/4
ALL DIMENSIONS ARE IN MM		SHEET NO : 03/04
		REV: _____ DATE: _____

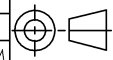

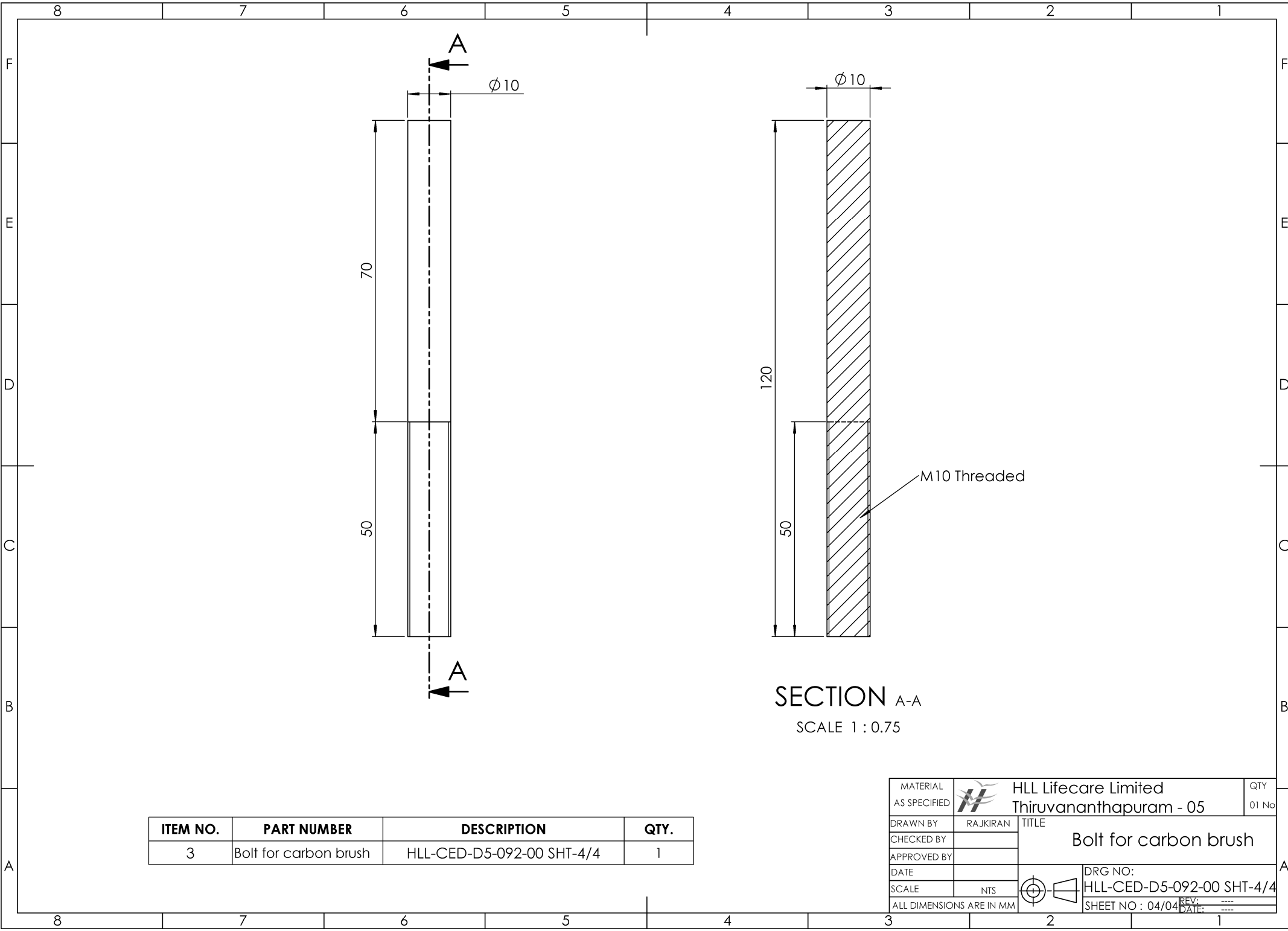

SECTION A-A
SCALE 1 : 0.75

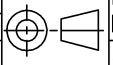

ITEM NO.	PART NUMBER	DESCRIPTION	QTY.
3	Bolt for carbon brush	HLL-CED-D5-092-00 SHT-4/4	1

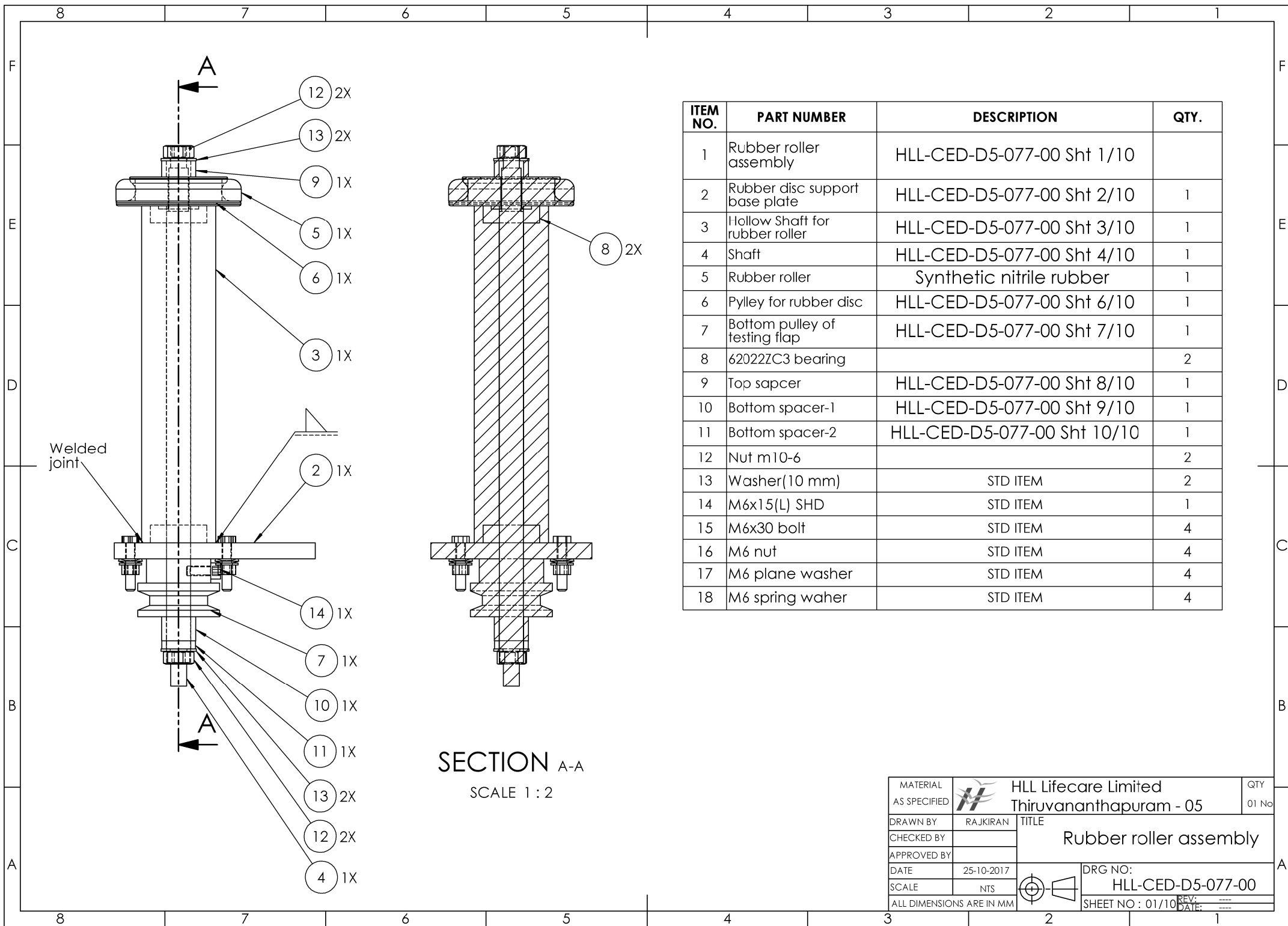
MATERIAL AS SPECIFIED	 HLL Lifecare Limited Thiruvananthapuram - 05	QTY
DRAWN BY		01 No
CHECKED BY	Bolt for carbon brush	DRG NO:
APPROVED BY		HLL-CED-D5-092-00 SHT-4/4
DATE		SHEET NO : 04/04
SCALE		REV: _____ DATE: _____
ALL DIMENSIONS ARE IN MM		



ITEM NO.	PART NUMBER	DESCRIPTION	QTY.
1	Rubber roller assembly	HLL-CED-D5-077-00 Sht 1/10	
2	Rubber disc support base plate	HLL-CED-D5-077-00 Sht 2/10	1
3	Hollow Shaft for rubber roller	HLL-CED-D5-077-00 Sht 3/10	1
4	Shaft	HLL-CED-D5-077-00 Sht 4/10	1
5	Rubber roller	Synthetic nitrile rubber	1
6	Pylley for rubber disc	HLL-CED-D5-077-00 Sht 6/10	1
7	Bottom pulley of testing flap	HLL-CED-D5-077-00 Sht 7/10	1
8	62022ZC3 bearing		2
9	Top sapcer	HLL-CED-D5-077-00 Sht 8/10	1
10	Bottom spacer-1	HLL-CED-D5-077-00 Sht 9/10	1
11	Bottom spacer-2	HLL-CED-D5-077-00 Sht 10/10	1
12	Nut m10-6		2
13	Washer(10 mm)	STD ITEM	2
14	M6x15(L) SHD	STD ITEM	1
15	M6x30 bolt	STD ITEM	4
16	M6 nut	STD ITEM	4
17	M6 plane washer	STD ITEM	4
18	M6 spring wاهر	STD ITEM	4

SECTION A-A
SCALE 1 : 2

MATERIAL AS SPECIFIED	 HLL Lifecare Limited Thiruvananthapuram - 05	QTY
DRAWN BY		RAJKIRAN
CHECKED BY	TITLE	Rubber roller assembly
APPROVED BY	DATE	25-10-2017
SCALE	NTS	DRG NO: HLL-CED-D5-077-00
ALL DIMENSIONS ARE IN MM	 	SHEET NO : 01/10 REV: ---- DATE: ----

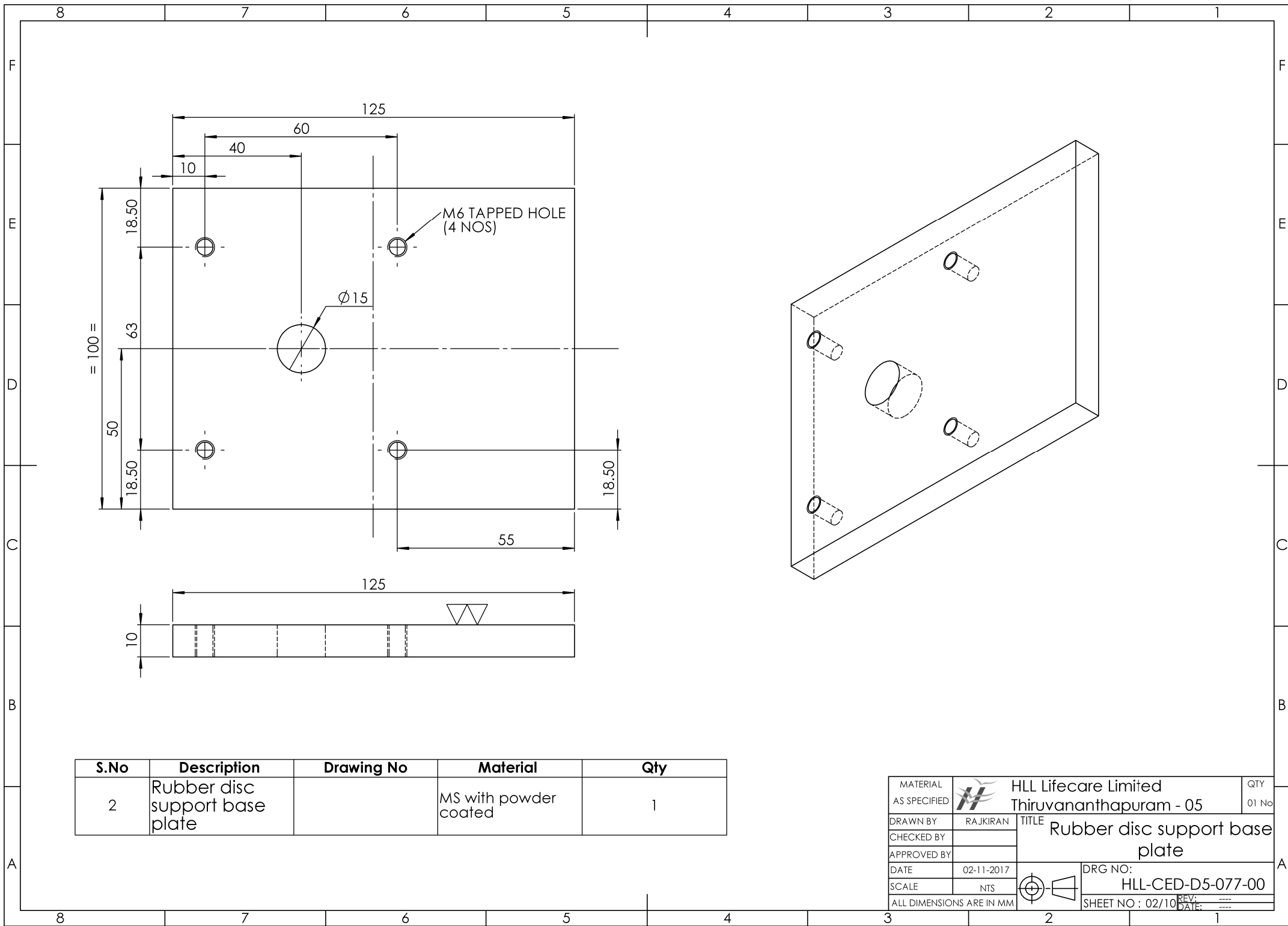

S.No	Description	Drawing No	Material	Qty
2	Rubber disc support base plate		MS with powder coated	1

MATERIAL AS SPECIFIED		HLL Lifecare Limited Thiruvananthapuram - 05	QTY 01 No
DRAWN BY	RAJKIRAN	TITLE Rubber disc support base plate	
CHECKED BY			
APPROVED BY			
DATE	02-11-2017	DRG NO:	HLL-CED-D5-077-00
SCALE	NTS	SHEET NO : 02/10	REV: ----- DATE: -----
ALL DIMENSIONS ARE IN MM			

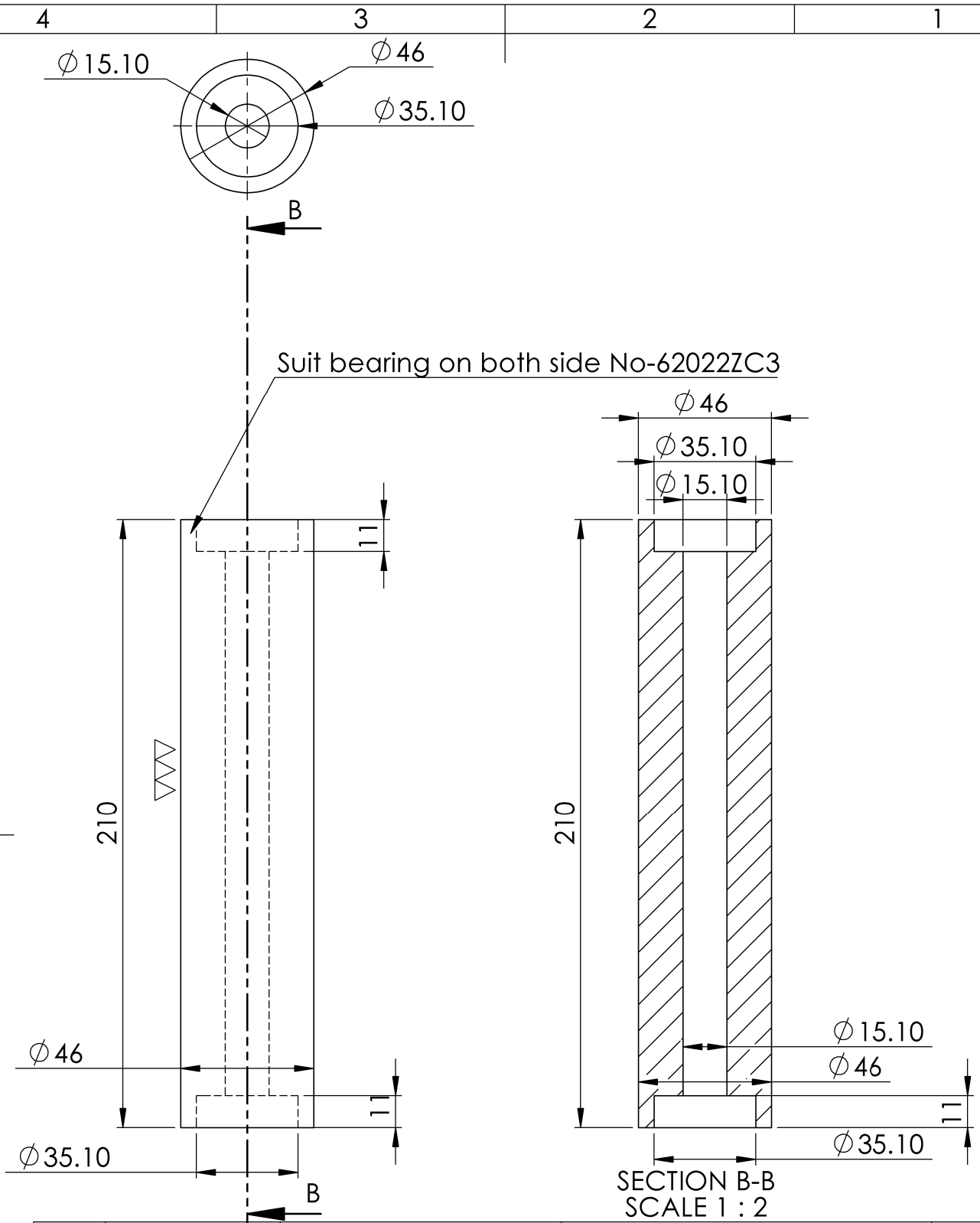

S.No	Description	Drawing no	Material	Qty
3	Hollow shaft		MS WITH POWDER COATED	1

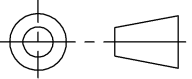
MATERIAL SS304		HLL Lifecare Limited Thiruvananthapuram - 05	QTY 01 No
DRAWN BY RAJKIRAN	TITLE Hollow shaft for rubber roller		
CHECKED BY			
APPROVED BY			
DATE 26-10-2017		DRG NO: HLL-CED-D5-077-00	
SCALE NTS		SHEET NO: 03/10	
ALL DIMENSIONS ARE IN MM		REV:	DATE:

4

3

2

1

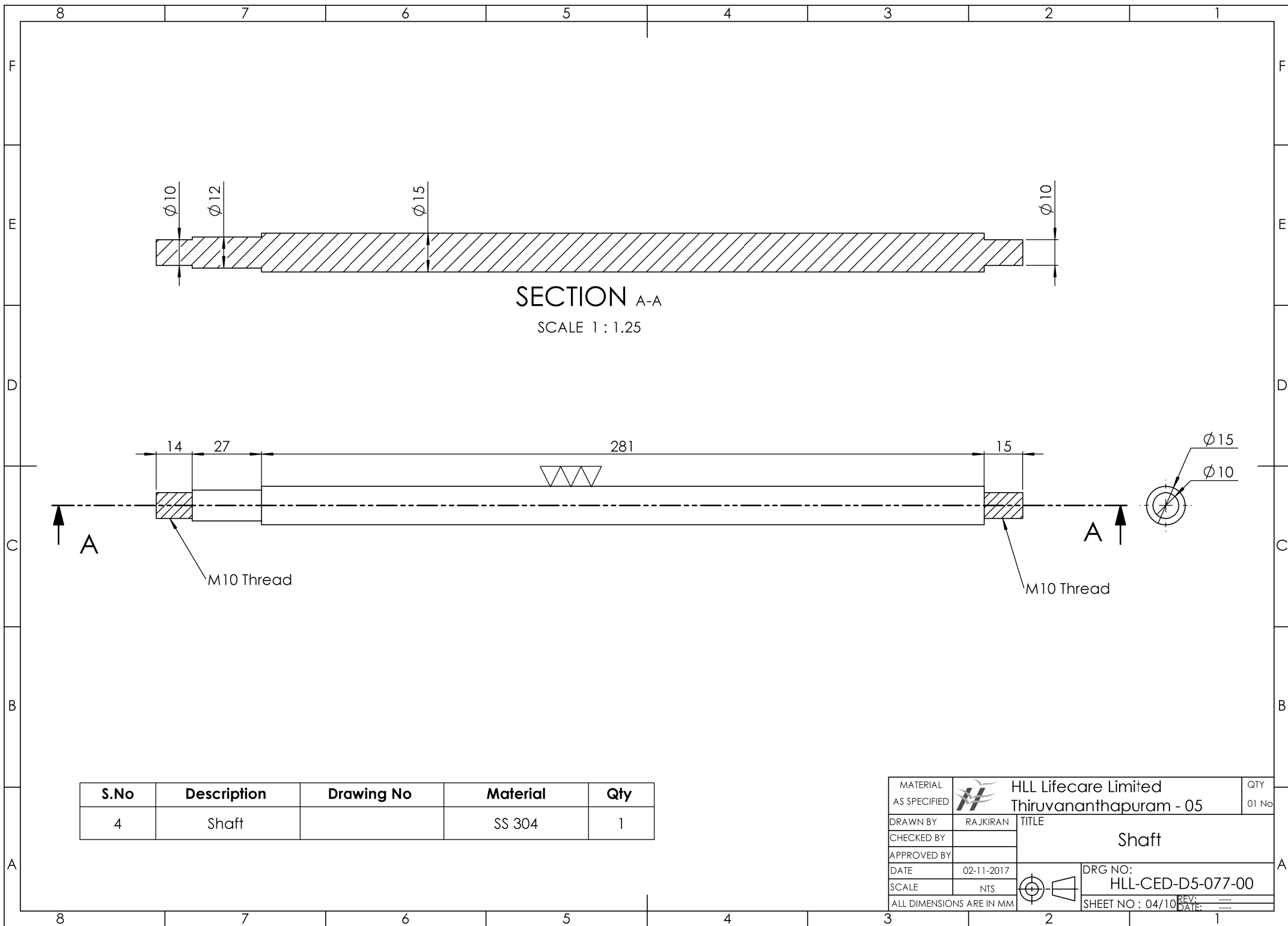

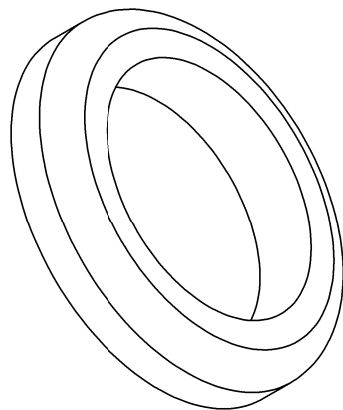
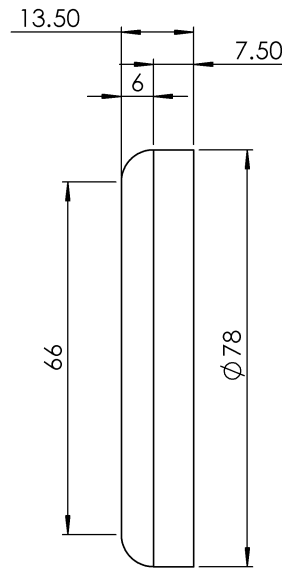
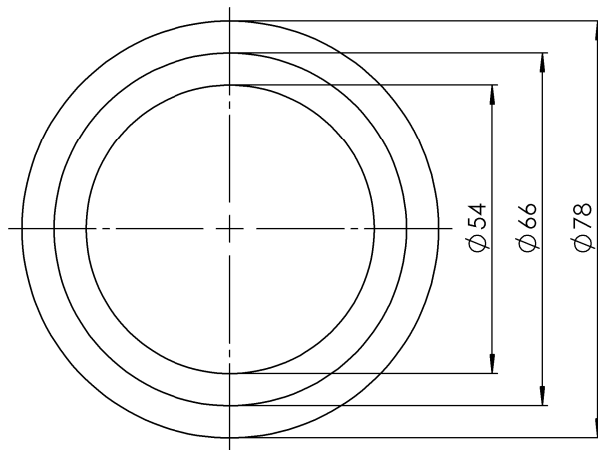

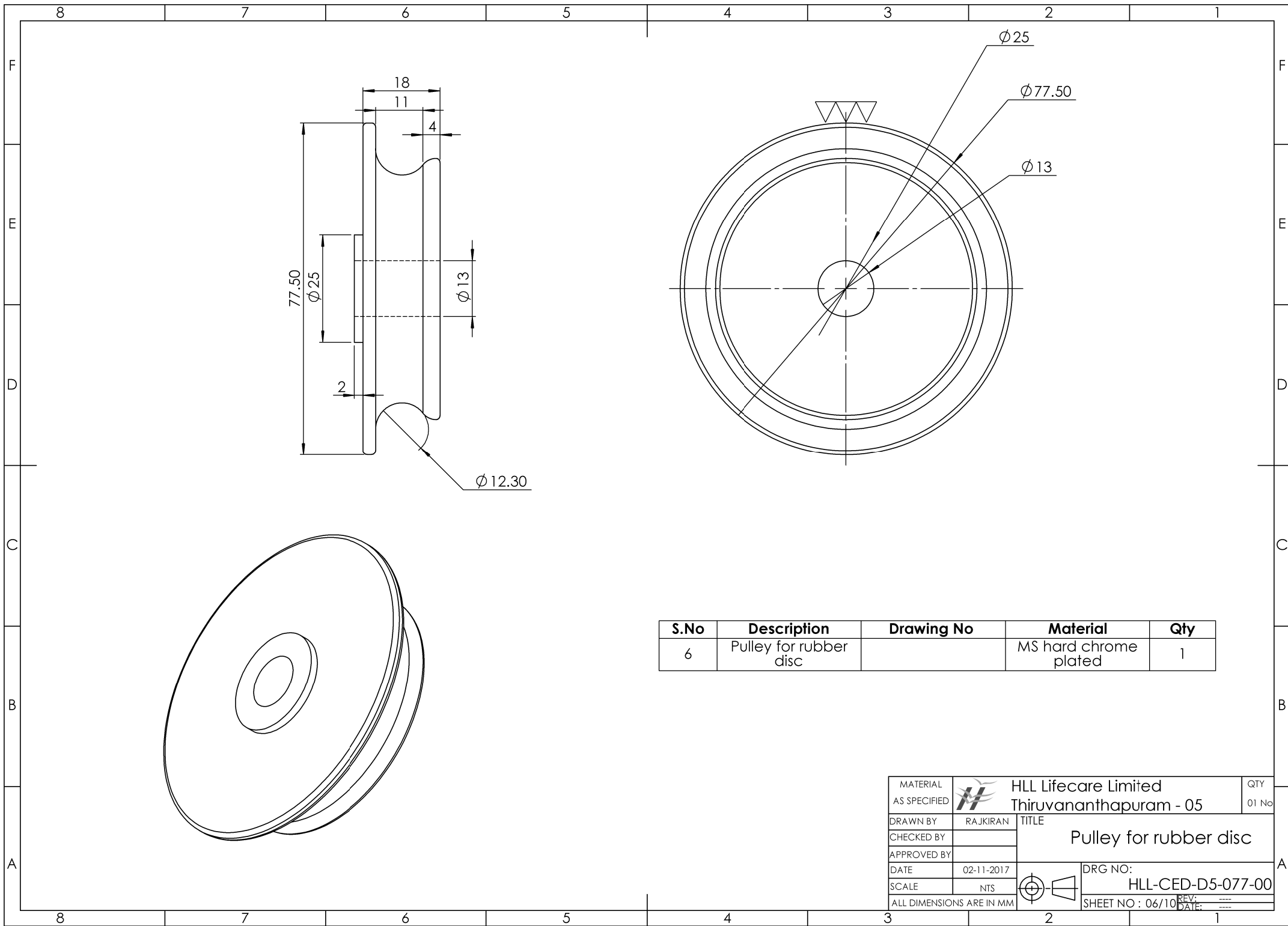

ITEM NO.	PART NUMBER	DESCRIPTION	QTY.
5	Rubber roller	Synthetic nitrile rubber	1

MATERIAL AS SPECIFIED	 HLL Lifecare Limited Thiruvananthapuram - 05	QTY 01 No
DRAWN BY	RAJKIRAN	TITLE Rubber roller
CHECKED BY		
APPROVED BY		
DATE	02-11-2017	DRG NO: HLL-CED-D5-077-00
SCALE	NTS	SHEET NO : 05/10
ALL DIMENSIONS ARE IN MM		REV: ---- DATE: ----



S.No	Description	Drawing No	Material	Qty
6	Pulley for rubber disc		MS hard chrome plated	1

MATERIAL AS SPECIFIED	 HLL Lifecare Limited Thiruvananthapuram - 05	QTY
DRAWN BY		RAJKIRAN
CHECKED BY		Pulley for rubber disc
APPROVED BY		
DATE	02-11-2017	DRG NO:
SCALE	NTS	HLL-CED-D5-077-00
ALL DIMENSIONS ARE IN MM		 DRG NO: HLL-CED-D5-077-00 SHEET NO : 06/10 REV: ---- DATE: ----

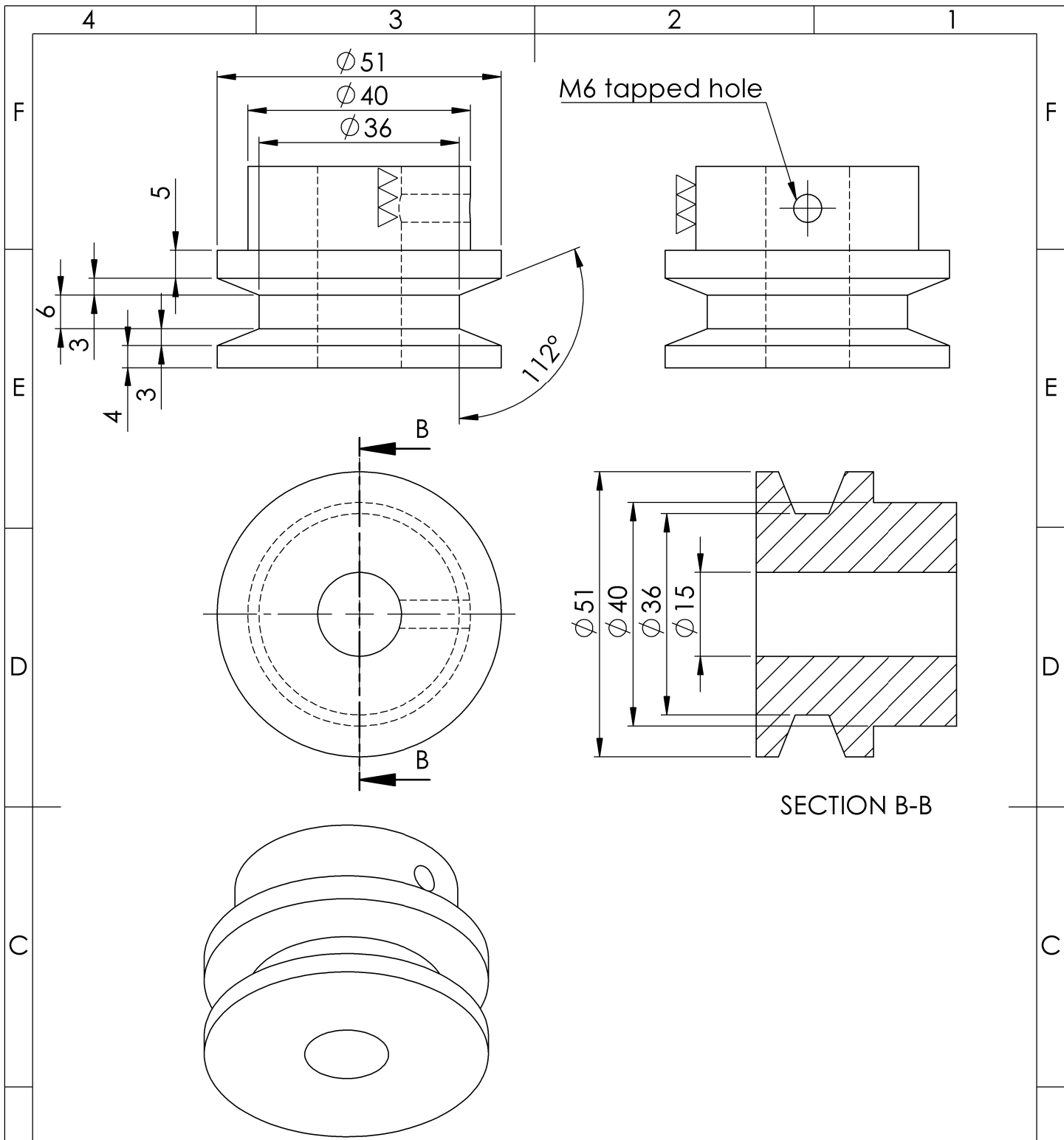

S.No	Description	Drawing No	Material	Qty
7	Bottom pulley		MS with Hard chrome plated	1

Weight of the Component : g (approx.)

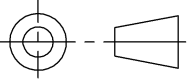
MATERIAL AS SPECIFIED		HLL Lifecare Limited Thiruvananthapuram - 05	QTY 01 No
DRAWN BY	RAJKIRAN	TITLE Bottom pulley of testing flap	
CHECKED BY			
APPROVED BY			
DATE	02-11-2017	DRG NO:	HLL-CED-D5-077-00
SCALE	NTS	SHEET NO:	07/10
ALL DIMENSIONS ARE IN MM			REV: DATE:

4

3

2

1

F

F

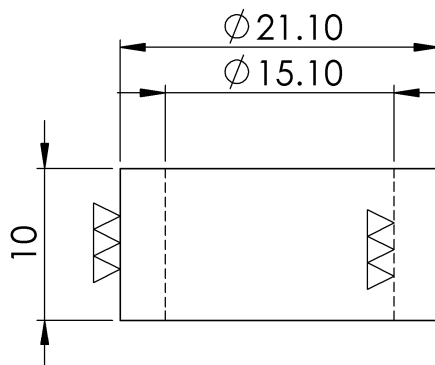

E

E

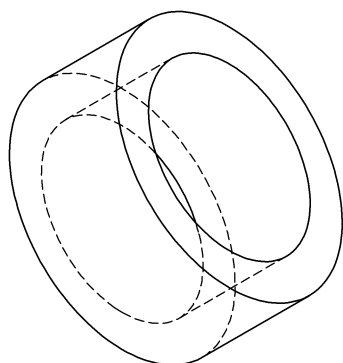

D

D

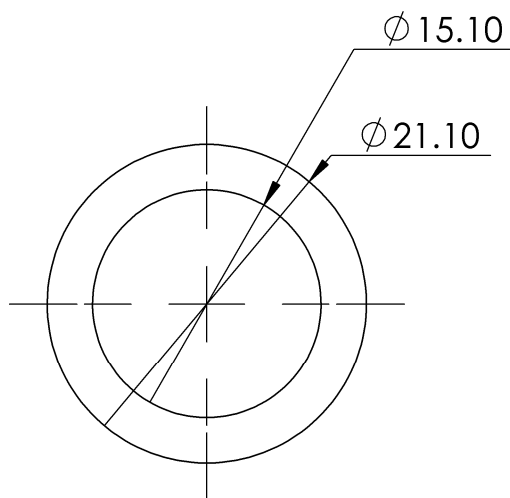

C

C

S.No	Description	Drawing No	Material	Qty
9	Top spacer		SS 304	1

B

B

Weight of the Component : g (approx.)

MATERIAL
AS SPECIFIED



HLL Lifecare Limited
Thiruvananthapuram - 05

QTY
01 No

DRAWN BY RAJKIRAN

TITLE

CHECKED BY

Top spacer

APPROVED BY

DATE 02-11-2017

DRG NO: HLL-CED-D5-077-00

SCALE NTS

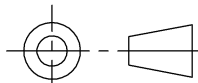

SHEET NO: 08/10

REV:
DATE:

ALL DIMENSIONS ARE IN MM

4

3

2

1

A

A

4

3

2

1

F

F

E

E

D

D

C

C

B

B

A

A

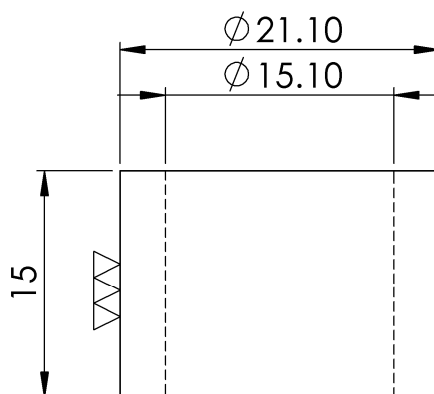
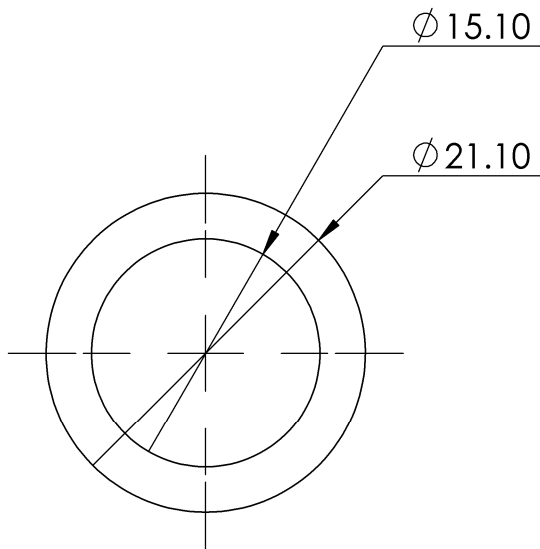
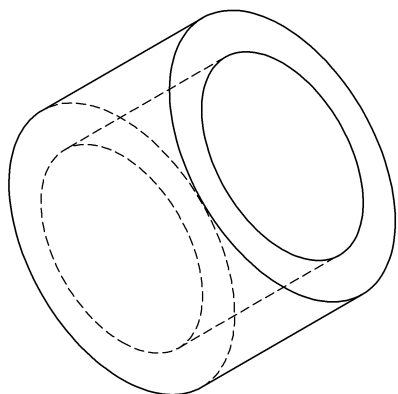

S.No	Description	Drawing No	Material	Qty
10	Bottom spacer-1		SS304	1

Weight of the Component : g (approx.)

MATERIAL AS SPECIFIED		HLL Lifecare Limited Thiruvananthapuram - 05	QTY 01 No
-----------------------	---	---	--------------

DRAWN BY	RAJKIRAN	TITLE	Bottom spacer-1
CHECKED BY			
APPROVED BY			

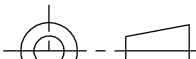
DATE	02-11-2017		DRG NO:	HLL-CED-D5-077-00
SCALE	NTS		SHEET NO: 09/10	REV:

ALL DIMENSIONS ARE IN MM			DATE:	
--------------------------	--	--	-------	--

4

3

2

1

4

3

2

1

F

F

E

E

D

D

C

C

B

B

A

A

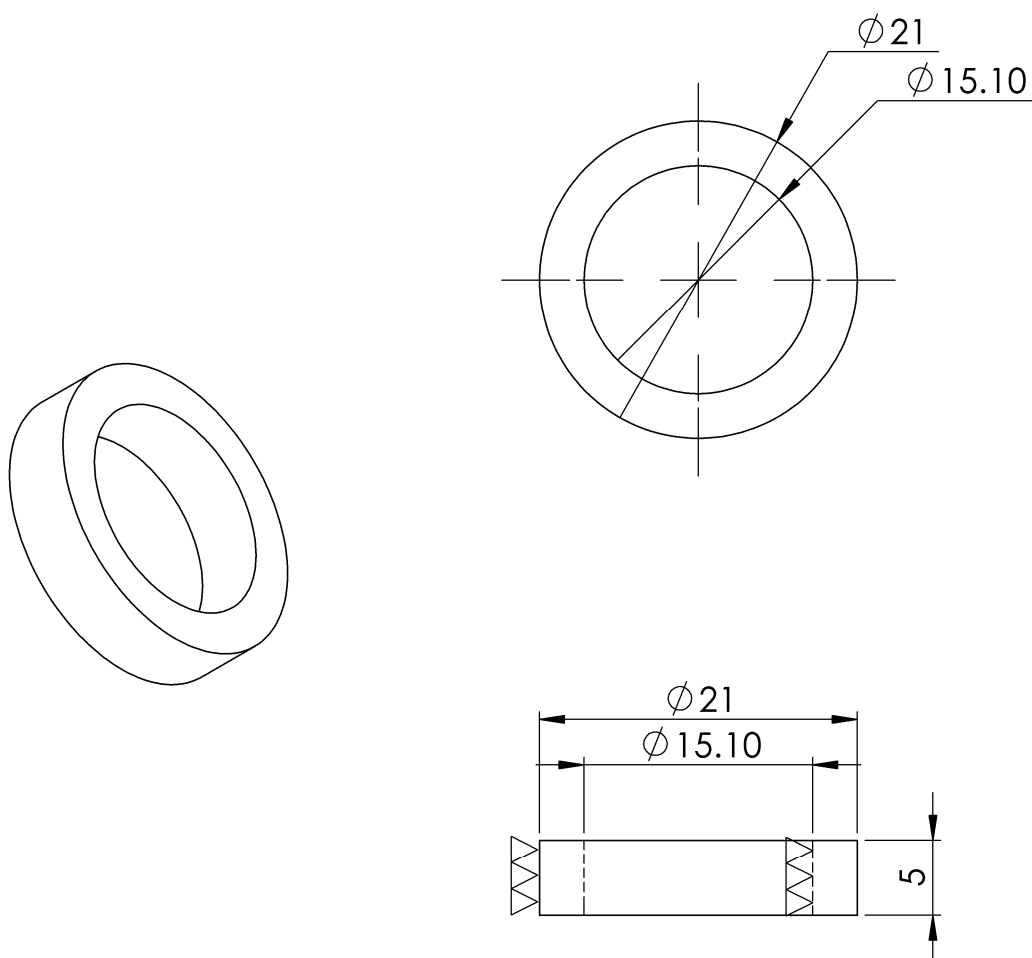

S.No	Description	Drawing No	Material	Qty
11	Bottom spacer-2		SS 304	1

Weight of the Component : g (approx.)

MATERIAL
AS SPECIFIED



HLL Lifecare Limited
Thiruvananthapuram - 05

QTY
01 No

DRAWN BY RAJKIRAN

TITLE

Bottom spacer-2

CHECKED BY

APPROVED BY

DATE 02-11-2017

SCALE NTS

ALL DIMENSIONS ARE IN MM

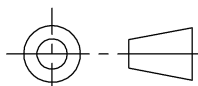

DRG NO: HLL-CED-D5-077-00

SHEET NO: 10/10

REV:
DATE:

4

3

2

1