

**Amendment no.1**

**23<sup>rd</sup> Sept ,2015**

Sub : Supply of Housing Assembly as per drawing No. HLL-B2-CED-23-01 and tender specifications at HLL, Irapuram Factory, Rubber Park,Irapuram.

Ref : IFB No:HLL/CED/IFC/HOUSING ASSY//2015 Date :19-09-2015

With reference to the above, we here by incorporate the following amendment to the tender documents as detailed below :

**Amendment no.1**

The last date of date for receipt and opening of bid of the above referred tender has been amended as follows.

- (a) Last date and time of receipt of tender : 03-10-2015,15.00Hrs
- (b) Date and time of opening tender : 03-10-2015, 15.30Hrs
- (c) Title

**EXISTING**

Supply of Housing Assembly as per **Drawing No. HLL-B2-CED-23-01** and tender specifications at HLL, Irapuram Factory, Rubber Park,Irapuram.

**READ AS**

Supply of Housing Assembly as per **Drawing No. HLL-B2-CED-23-02** and tender specifications at HLL, Irapuram Factory, Rubber Park,Irapuram

- (d) Drawing

**EXISTING**

# EXISTING DRAWING

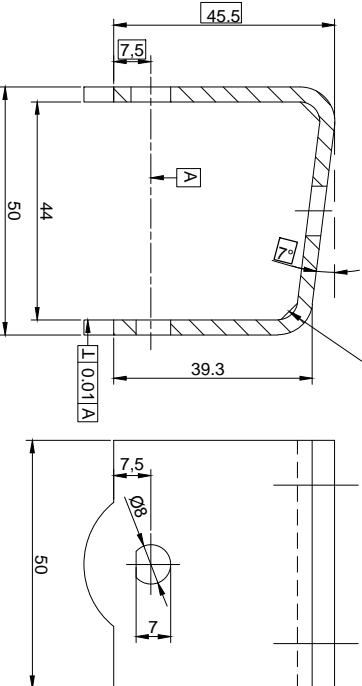
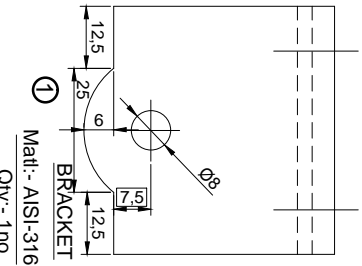
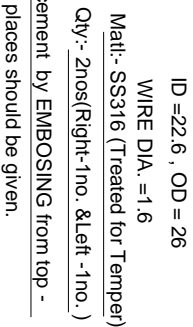
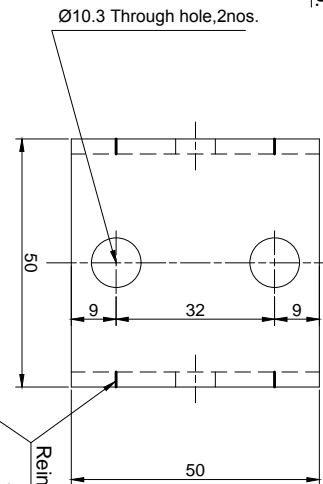
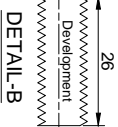
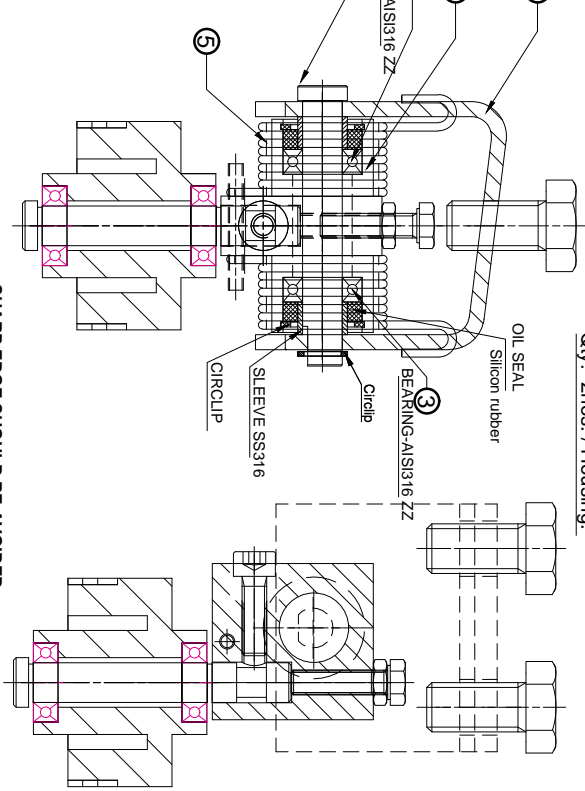
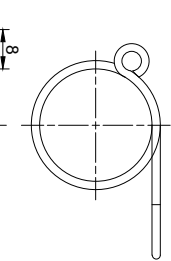
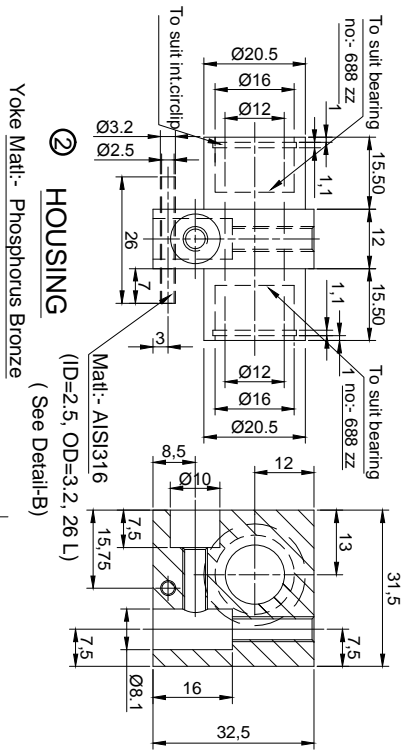
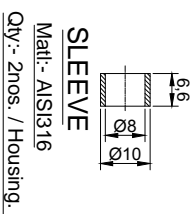
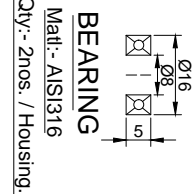
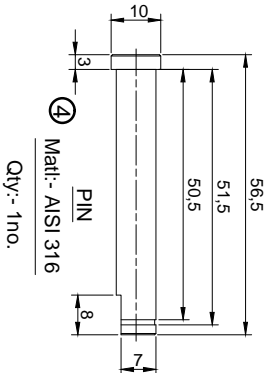
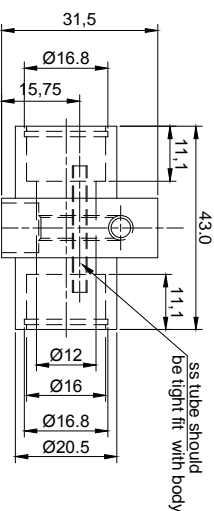

## SUPPLEMENTARY ITEMS TO BE SUPPLIED AS PER DRG.

- 1) External circlip shaft dia=8, Qty -2nos/assy.(Heavy duty)-AISI304 (Treated for Temper)
- 2) Hex socket head screw M5x0.8x16 length =1no. - AISI 304
- 3) Hex bolt & nut M10x1.5x20L&25 length =1no.each(Make:-APL/KUN) - AISI 304
- 4) Hex bolt(AISI 304) M5x0.8x20 length & lock nut =1no.(Make:-APL/KUN)
- 5) Bearing no. L-16800.Silicon rubber sealed,Make:- NTN SINGAPORE.(688 2RH) Qty -2nos/assy.
- 6) Oil Seal. Silicon Rubber.ID=10,OD=16,Thk.4, Qty:-2nos/assy.
- 7) Internal circlip, Dia 16 Qty:-2nos/assy.(heavy duty) AISI 304(Treated for Temper)
- 8) Material Test Certificate Should be Produced.

## ASSEMBLY

SHARP EDGE SHOULD BE AVOIDED  
SECTIONAL SIDE VIEW

MATERIAL:	HLL LIFE CARE LIMITED.	NO.OFF.
DRAWN BY:	PAUL M.P	
CHECKED BY:		
APPROVED BY:		
DATE:	05-09-2014	
SCALE:		
ALL DIMENSIONS ARE IN M/M		

TITLE:-	HOUSING ASSEMBLY PARTS FOR MOLD HOLDER (BTADL CDM) FOR IFC
Drwg. no.:	HLL-B2-CED-023-01
SHEET NO.:	1OFF. 1
REV.:	01
DATE:	12-9-2015

# READ AS

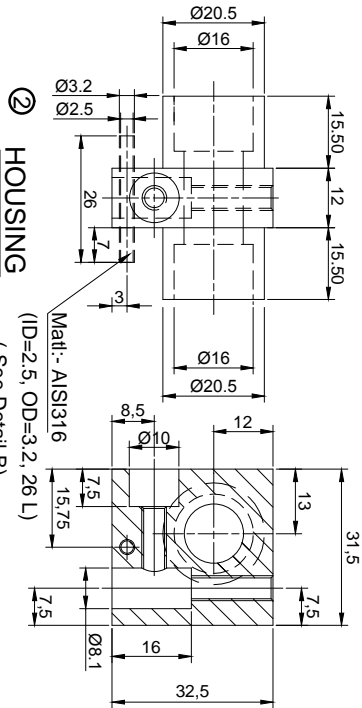
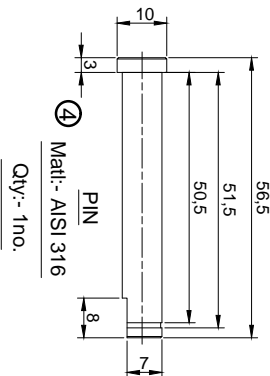
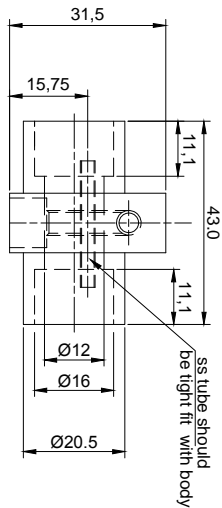

② HOUSING  
 Yoke Matl:- Phosphorus Bronze  
 Qty:- 1no.

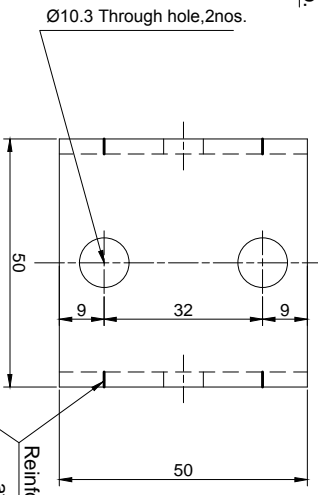
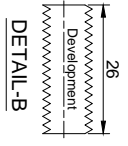

⑤ TENSION SPRING (Right & Left)  
 ID = 22.6 , OD = 26  
 WIRE DIA. = 1.6  
 Matl:- SS316 (Treated for Temper)  
 Qty:- 2nos(Right-1no. & Left - 1no.)  
 Reinforcement by EMBOSING from top -  
 at 4 places should be given.

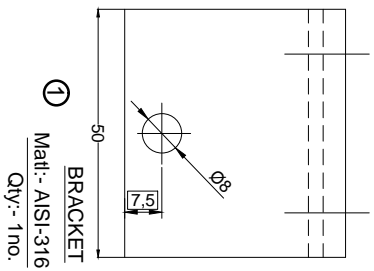
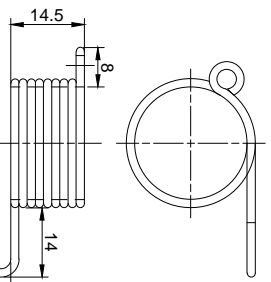

① BRACKET  
 Matl:- AISI-316  
 Qty:- 1no.

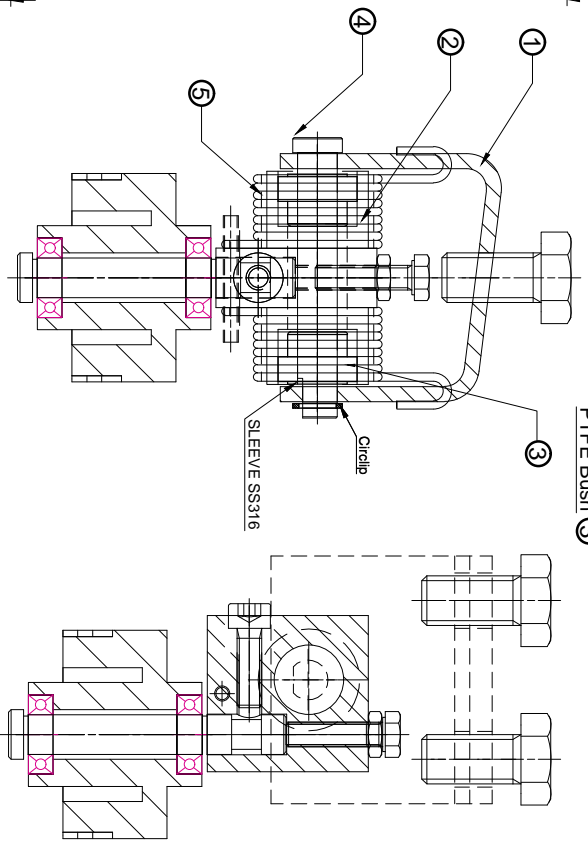
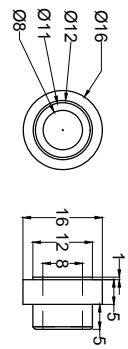
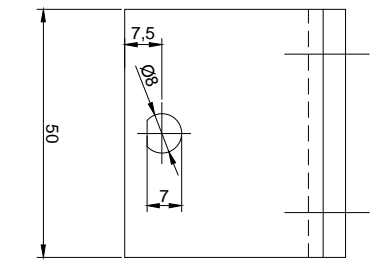
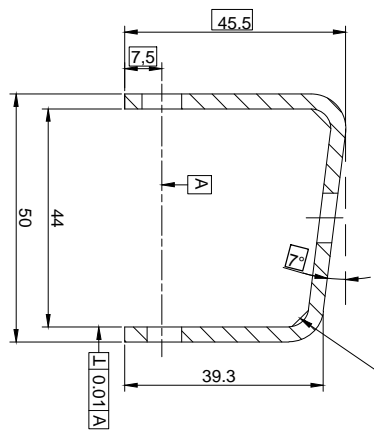

- SUPPLEMENTARY ITEMS TO BE SUPPLIED AS PER DRG.
- External circlip shaft dia=8, Qty -2nos/assy.(Heavy duty)-AISI304 (Treated for Temper)
  - Hex socket head screw M5X0.8x16 length =1no. - AISI 304
  - Hex bolt & nut M10x1.5x20L & 25 length =1no.each(Make:-APL/KUN) - AISI 304
  - Hex bolt(AISI 304) M5X0.8x20 length & lock nut =1no.(Make:-APL/KUN)
  - Bush material (PTFE- Poly Tetra Fluoro Ethylene)
  - Material Test Certificate Should be Produced.

MATERIAL:	HLL LIFE CARE LIMITED.		NO.OFF.
DRAWN BY:	PAUL M.P	Thiruvananthapuram-5	
CHECKED BY:		HOUSING ASSEMBLY PARTS FOR MOLD	
APPROVED BY:		HOLDER (BTADL CDM) FOR IFC	
DATE:	05-09-2014	(WITH BUSH)	
SCALE:			
ALL DIMENSIONS ARE IN M/M			
		Drg .no:-HLL-B2-CED-023-02	REV:01
		SHEET NO.-1OFF. 1	DATE:-23-9-2015

All other conditions are as per the original IFB No :HLL/CED/IFC/HOUSING ASSY//2015

Dated 19-09-2015

**ASSOCIATE VICE PRESIDENT(CED)**