

MINUTES OF THE MEETING

TENDER FOR SUPPLY & INSTALLATION OF STAINLESS STEEL (SS) FURNITURE AT PII, COONOOR

Document No. : NPI/110831/EQP/ TD/16
Venue : HLL Biotech Limited, Chennai
Date : 19th Jan,2017
Project : Revival of DPT Vaccines manufacturing facility
Attendees : See attached list of attendees
Issued on : 20th Jan'2017
Issued by : Mr.Suresh .S (DGM – Procurement)

Agenda	
1.	Pre-bid Meeting for Stainless Steel (SS) Furniture at PII, Coonoor.

A. Discussion on General points		
1	In Section – I, Notice Inviting Tender (NIT) of TED (Page No. 3/82) the EMD amount is revised as Rs. 3,70,000/- . The EMD should be provided as per Clause No. 18 of TED (Page No. 17 & 18).	
2	Addition /Deletion which is revised during the pre-bid is highlighted in red colour in the Annexure -1 (attached with this Pre-bid MoM)	
3	Vendor/Supplier/Tenderer must state “complies” in each drawings, Annexure-1 and pre-bid MoM along with signature and seal.	
4	SECTION – XI A PRICE SCHEDULE i) PRICE SCHEDULE FOR DOMESTIC GOODS OR GOODS OF FOREIGN ORIGIN LOCATED WITHIN INDIA - template is Attached as Annexure-2, vendor must quote according to this.	
5	The loading, unloading, positioning, installation as per site plan and supervision is in vendor’s scope.	
6	Section No.VI &VII is replaced with Annexure-1	
7	Section No.1 (NIT) –Table contents like items description,Tech Spec. Ref No. and Qty is revised and available in Annexure-1	
8	Bidder has to submit only Power of Attorney as per TED (Point 5 of Page 5).	
9	Henceforth, this Pre-bid MOM has to be considered as a part of the original tender.	
B. Discussion on Drawings /Technical Specification		
Sl. No.	Drawings /Technical Specification Ref No.	Point /Comments Modified As
1	Chair (Heigt Adjustable) Tech Spec Ref.No. HLL/PIIC/SS-FRN 1	a. Cross pipe dimensions is included as 12 mm dia with 18 SWG
2	COB Tech Spec Ref.No. HLL/PIIC/SS-FRN 2	a. Square pipe dimensions is included as 30 mm x 30 mm with 16 SWG
3	Garment bin Tech Spec Ref.No. HLL/PIIC/SS-FRN 5	a. Each Garment Bin to be supplied with 3 nos. of washable ,Autoclave able, Re-useable and non-shredding material bag (similar to clean room garment) with hanging provision in the garment bin
4	Gloves and hand Dis-infectant Tech Spec Ref.No. HLL/PIIC/SS-FRN 6	a. To be designed for 500 ml square bottle.
5	Lockers Tech Spec Ref.No. HLL/PIIC/SS-FRN 7	a. The pad lock must be Godrej make with 3 keys
6	Rack Tech Spec Ref.No. HLL/PIIC/SS-FRN 8	a. The adjustable shelves shall be made of either by double bended with stiffener at the bottom or by using thick pipe with the dimmensions provided in the drawing. b. vendor must consider 10 mm x 18 mm bolt & Nut with washer c. Vendor must consider total 9 Nos. Of Adjustable spanner and 9 nos.of empty tool box (S.S).
7	Rack - 2 tier Tech Spec Ref.No. HLL/PIIC/SS-FRN 8	a. Rack -2 tier refers to racks in two seperate part due to increase in length. b. Common comments similar to Rack (i.e point no.a,b & c)
8	Cold Room Racks Tech Spec Ref.No. HLL/PIIC/SS-FRN 8	a. 4 Nos. of Adjustable shelves shall be provided instead of 5 nos. b. Common comments similar to Rack (i.e point no.a,b & c)
9	Shoe rack with exhaust Tech Spec Ref.No. HLL/PIIC/SS-FRN 10	a. The Exhaust duct must be rectangle type with approx. 2 m height and to be provided with counter flange and the duct shall be made of 18 SWG.
10	Work Table Tech Spec Ref.No. HLL/PIIC/SS-FRN 11	a. Square pipe to be considered as 32 mm with 16 SWG.
11	Work table with drawer Tech Spec Ref.No. HLL/PIIC/SS-FRN 12	a. Square pipe to be considered as 25 mm with 16 SWG.

12	Work table with sink Tech Spec Ref.No. HLL/PIIC/SS-FRN 13 & 29	a. Sink dimension to be considered as 450 mm (L) x 450 mm (W) x 300 mm (D) b. Top sunk type should be made using the same top sheet with out any cut.
13	Wash Tub Tech Spec Ref.No. HLL/PIIC/SS-FRN 14 & 29	a. Sink depth to be considered as 500 mm. b. Square pipe to be considered as 30 mm with 16 SWG.
14	Pallet Tech Spec Ref.No. HLL/PIIC/SS-FRN 15	a. Leg & Cross over shall be considered as Square pipe with 30 mm and 16 SWG
15	Platform trolley Tech Spec Ref.No. HLL/PIIC/SS-FRN 16	a. Square pipe to be considered as 25 mm with 16 SWG.
16	Trolley-Closed type with removable shelves Tech Spec Ref.No. HLL/PIIC/SS-FRN 17	a . Handle to be considered as 25 mm dia with 16 SWG. b. M.O.C of the Wheels to be considered as Nylon
17	SS Janitor Closet Tech Spec Ref.No. HLL/PIIC/SS-FRN 18	a . Entire body to be considered with 18 SWG. b. Leg to be considered with Square pipe of 30 mm with 16 SWG.
18	Floor Cleaning trolley Tech Spec Ref.No. HLL/PIIC/SS-FRN 19	a . Each portable container with lid should have a mimn capacity of 10 lts. b. Mop holding design to be provided and waste water while squeezing of mop should not fall in ground. c. During operation ,the Lids should be able to be kept in the trolley seperately.
19	Glove Box Tech Spec Ref.No. HLL/PIIC/SS-FRN 20	a . Option "A" to be considered.
20	Settle plate stand Tech Spec Ref.No. HLL/PIIC/SS-FRN 22	a .Tray Height to be considered as 25 mm b. Leg to be considered as 25 mm hollow pipe with 16 SWG instead of 10 mm rod.
21	Staning Chamber Tech Spec Ref.No. HLL/PIIC/SS-FRN 26	a . Each unit to be provided with tube & pinch clamp for the tray drain.
22	Mobile Sink Tech Spec Ref.No. HLL/PIIC/SS-FRN 28	a. Fresh Water tank capacity shall be 20 Lts. and collection tank shall be 25 lts. b.Sink drain to be considered as rigid pipe with TC clamp joint with the collection tank.
23	Open Trolley Tech Spec Ref.No. HLL/PIIC/SS-FRN 30	a . New Addition – refer drawing and Annex.1 for specification and quantity
24	Office Cupboard and Eye washer Tech Spec Ref.No. HLL/PIIC/SS-FRN 31	a . New Addition – refer drawing and Annex.1 for specification and quantity

For HLL Biotech Limited

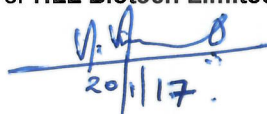
20/1/17.

DGM (Procurement)

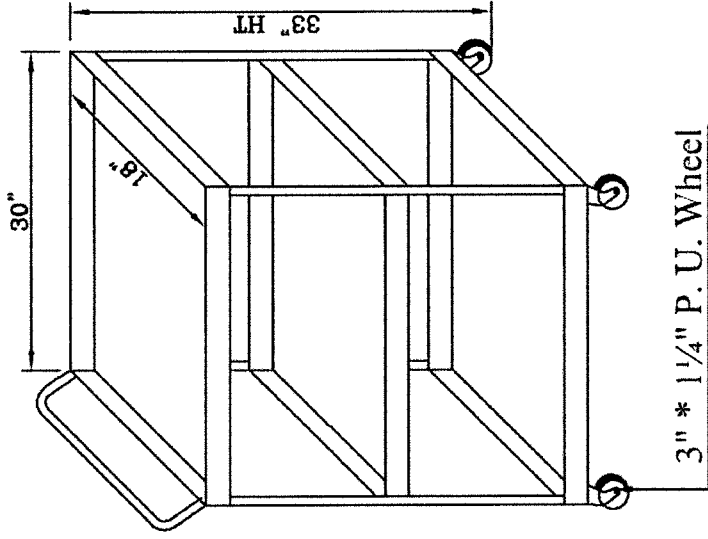

Open Trolley

MOC :- SS 304 Qlty * 18 swg

25mm Round pipe
selves height 50 mm

FINISH :- 240 GRIT - MIRROR POLISH

Tech. Spec. Ref. No. : HLL/PIIC/SS-FRN 30

DATE :- 19-01-2016

1. The Drawing are for representation only Vendor to design & take approval before manufacturing.
2. Factory Inspection for each design if mandatory before manufacturing entire lot.

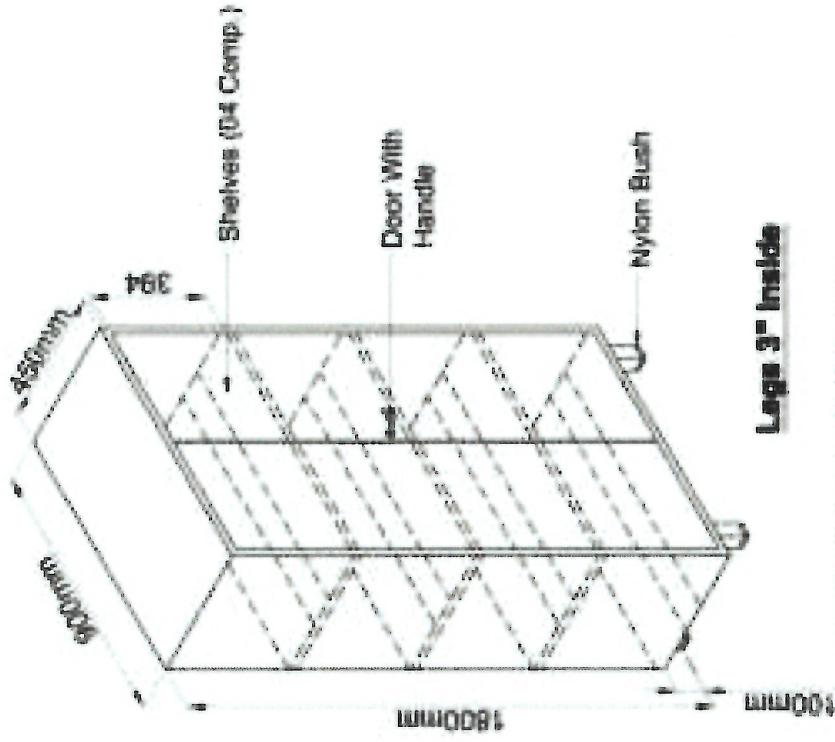

OFFICE CUPBOARD

MOC :- SS 304 Qty * 18 swg
 Leg 30mm * 30mm - 16swg
 Lock & Key
 FINISH :- 240 GRIT - MIRROR POLISH
 Tech. Spec. Ref. No. : HLL/MIC/SS-FRN 31
 DATE :- 19-01-2016

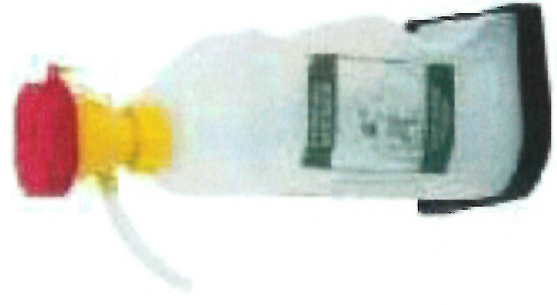

EYE WASHER

1. The Drawing are for representation only Vendor to design & take approval before manufacturing.
2. Factory Inspection for each design if mandatory before manufacturing entire lot.

HLL BIOTECH LIMITED, CHENNAI				
REVIVAL OF DPT VACCINE MANUFACTURING FACILITY, PII, COONNOOR				
List of SS furnitures and other miscellaneous equipments				
NPI/110831/DOC/EQP(SS)/06				
02.01.2016 Rev -4				
Sr. No.	SS furnitures	Equipment ID	Dimension & Specification (mm)	Quantity
Annexure 1				
1	Chair (Height Adjustable) Tech Spec Ref.No. HLL/PIIC/SS-FRN 1	B1G047_03,B1G057,B1G064,B1G008,B1G018,B2G026_4,B2G028_2,B2G043,M1G022,M1G025_02,M1G028,M1G029,M1G033,M1G037,M1G038,A1G012,A1F014,A2G019,B1G048_3,B1G055,B1G060,B1G083_2,B1G077,F1G023_4,F1G027_12,F1G028_2,F1G038_2,F1G055,,F1G057_2,F1G032_2,F1G032A,F1F009,F1F010,Miscellaneous_3,M1_misc_8,B2G043_3,B1G060_2,A1G012,A1G023,A1F014,A2G009,A2G012,A2G015,A2G018_2,W1B_8,	400 (L) x 350 (w) x500 (H) mm	93
2	COB Tech Spec Ref.No. HLL/PIIC/SS-FRN 2	B1G076,B1G030,B1G071,B2F016,F1G034,M1G018,A1F007,B2F007,B2F016 B1G013,B1G022,B2G044,B2G044A,M1G035,F1G053,M1F010,A2G003,A2G023,B2G044,B2G044A, B1G003,B1G042 B1G034,B1F019,B2G013,B2F007,F1G054,F1F008 B1F004,B1F009 B1F026,F1G046,W1B005,W1B006,M1F010,M1G035 B2G004,B2G008,M1F009 B2G015,B2G017,B2G041 F1G004,F1G008 F1G044, F1G045 F1G050,M1F009,W1G022, M1G004,M1G007 A1G005 B1G063,, A2G004_2 ,M1G002 A1G005,A2G003,A2G023	1800 (L) x 400 (W) x 550 (H) 1200 (L) x 400 (W) x 550 (H) 2100 (L) x 400 (W) x 550 (H) 2000 (L) x 400 (W) x 550 (H) 3000 (L) x 400 (W) x 550 (H) 1400 (L) x 400 (W) x 550 (H) 2600 (L) x 400 (W) x 550 (H) 1000 (L) x 400 (W) x 550 (H) 1700 (L) x 400 (W) x 550 (H) 800 (L) x 400 (W) x 550 (H) 1500 (L) x 400 (W) x 550 (H) 1600 (L) x 400 (W) x 550 (H) 2200 (L) x 400 (W) x 500 (H) 1500 (L) x 400 (W) x 500 (H) 1200 (L) x 400 (W) x 550 (H) 2000 (L) x 400 (W) x 550 (H)	9 11 2 6 2 6 3 3 2 1 1 3 2 1 2 3
3	Disposable bin Tech Spec Ref.No. HLL/PIIC/SS-FRN 3	B1G030,B1G071,B1G003,B1G042,B2G013,A2G003,A2G012,A2G020,A2G021,B2G026,B2G027,B2G028_2,B2G039,B2G043,B2G053,B2G030,W1G022,M1_misc_12,B2G054_2,B1G076_7,F1_misc_5,A1G005,A1G018,A1G019,A1F007,A1F017_2,A2G012_2,W1B_6, Meat Container A2G021,A1G019,A1F018	(300x450) (D x H)	58
4	Carcass Collection Bin Tech Spec Ref.No. HLL/PIIC/SS-FRN 4		(290x550) (D x H) mm ,simple container with lid (300x600) (D x H)	8 3

5	Garment bin Tech Spec Ref.No. HLL/PIIC/SS-FRN 5	B1G076,B1G030,B1G071,B1G003,B1G042,B1F014,B1G034,B1F019,B1F004, B1F009,B1F026,B2G004,B2G008,B2G013,B2G020,B2G023,B2G028,B2G 044,B2G044A,B2F007,B2F010_2,B2F01M1F007_2,A1G005,A1F007,A2G00 3,A2G023,W1G021,W1G0221_2,,B2F016,F1G034,F1G046,F1G049,F1G050 _1,F1G051,F1F006_3,F1F007_2,M1G004,M1G007,M1G036,M1F009,M1F00 2_3_B1G047,F1G046	450 mm (L) x 450 mm (W) x 1000 mm (H)	52
6	Gloves and hand Dis-infectant Tech Spec Ref.No. HLL/PIIC/SS-FRN 6	B1G042,B2G015,B2G017,M1G018,M1G035,A1G018,A1F017,A2G020,D&P Miscellaneous_5,B2G019,B2G022,B2G026,B2G027,B2G028,B2G039,B2G0 43,M1G022,M1G028,M1G029,M1G033,M1G037,M1G038,A1G013,A1G01 6,A1F01,A1F013,A1F015,A1F022,A2G009,A2G010,A2G016,A2G017,A2G0 18,A2G019,A2G021,B1G008,F_	Refer drawing	68
7	Lockers Tech Spec Ref.No. HLL/PIIC/SS-FRN 7	Miscellaneous_12,Miscellaneous_4,B1G008_4,B1G047_8, B1G076,B1G034,B1F017,B2F016,F1G034,F1F008,M1F009,M1F010,A2G02 3,B1F019,B1F026,B2G003,B2G006,B2G019,B2G022,B2G016,F1G043,F1G0 50,M1G18,W1G021,W1G022,W1B005,W1B006,A1G018,A1F017,A2G003, B1F003_2,B1F008,A1G005,F1G004,F1G008,M1G004,M1G007,A1F007,B2 G003_3,F1G004_3,F1G008_3,A1G005,A2G003,A2G020,W1B_2,	900 (L) x 400 (D) x 1800 (H) - 15 Lockers	49
8	Rack Tech Spec Ref.No. HLL/PIIC/SS-FRN 8	B1F017,F1G013_2,F1G014_2,F1G015_2,F1G023,F1G024,F1G027,F1G028, F1G029,F1G030,F1G032,F1G035,F1F009,F1F010,M1G012,M1G014 _2,M1G024,M1G028,M1G029,M1G033,M1F006_2,M1F008,W1G024,W1 G025,W1G026,A1G012_2,A1G015_2,A1G019,A1G023_2,A1F012_2,A1F01 4,A1F01,,A1F022,A2G012,B1G077_2,B1G080,B1G054,F1G032A,F1G056A 2G007,B2G054_2,F1G013_2,F1G015,F1G023_2,F1G035,F1F009,A1F015,A 1F018,A2G017	(1500x500x1800) (LxWxH)	62
9	Rack - 2 tier Tech Spec Ref.No. HLL/PIIC/SS-FRN 8	B2G047,B2F009 B1G055_3,B1G051 B1G055,B1G050,B1G053 B1G050,B1G067,B1G067 B1G053 F1G017,B2G030_4 F1G017,B2G036_4 F1G017 F1G029_7,M1G023_2,B1G020,F1G030_7,B2G031_5 B1G020	(2500x500x1800) (L x W x H) (3700x500x1800) (L x W x H) (1500x500x1800) (L x W x H) (5500x500x1800) (L x W x H) (3400x500x1800) (L x W x H) (1500x500x1800) (L x W x H) (5800x500x1800) (L x W x H) (7800x500x1800) (L x W x H) (1500x500x1800) (L x W x H) (6400x500x1800) (L x W x H)	4 3 3 1 5 5 1 22 2
10	Cold Room Racks Tech Spec Ref.No. HLL/PIIC/SS-FRN 8	B1G076,B1G030,B1G071,B1G034,B1F004,B1F009_2,B1F026,B2G004,B2G 008,B2G013,B2G020,B2G023,B2G044,B2G044A,F1G046_2,F1G049,F1G05 1,W1G0.1,A1F018,,B2G019_2,B2G022_2,	(300x600) (D x H)	25
11	Shoe bin Tech Spec Ref.No. HLL/PIIC/SS-FRN 9			

12	Shoe rack with exhaust Tech Spec Ref.No. HLL/PIC/SS-FRN 10	B1F003,M1G005,B1F008,B2G003,F1G002_2,M1G002,A1G005,A2G003,A2G023,W1B005	1500 (L) x 350 (W) x 1100 (H) mm	11
		B1G047_2,B1G008_2,B1G009,F1G032,A2G016, B1G048_2,B1G028,B1G048_2	(2200x900x650) (L x H x W) mm	7
		B1G083_2,B1G023,B1G041,B1F018,B1G035	(1600x900x650) (L x H x W) mm	5
		B2G026_4,B2G028_3,A1F014,A2,018,B2G054_2	(1400x900x650) (L x H x W) mm	6
		B2G048,B2F008,F1F010_2,M1G039_2,M1F008_2,W1G024,B1G090,M1_2, Misc_4,B2G026	(1800x650x900) (L x W x H) mm	11
13	Work Table Tech Spec Ref.No. HLL/PIC/SS-FRN 11	B2G026,B2G027,B2G028,F1G032_2,F1G032A,F1G038_2,F1G042_2,F1G07, M1G012,M1G022_2,M1G025,M1G028,M1G029,M1G033,M1G037,M1G038, M1G039_2,W1G025,W1G026,A1G012_2,A1G013,A1G014_2,A1G015 A1G0162,A1G019,A1G023,A1F011,A1F012,A1F013,A1F018,A1F019_2,A 1F022_2,A2G009,A2G011A2G012_2,A2G015,A2G016,A2G019,A2G021,B 1G060,B1G064,B1,069,B1G077_2,B1G090,B2G051,F1F023_2,F1F027_2, F1F028,F1F039,F1F055,A2G010,B1G037_2,B2G026_3,F1G059,A1G012, A2G019_2	(1100x650x900) (L x W x H) mm	74
		F1G023_3	(900x450x450)(L x W x H) mm without central sleeves	6
14	Work table with drawer Tech Spec Ref.No. HLL/PIC/SS-FRN 12	F1F028,F1_Misc_4,W1B_3,	1100x650x900) (L x W x H) mm	8
15	Work table with sink Tech Spec Ref.No. HLL/PIC/SS-FRN 13 & 29	B1G059,B1G038,B1G077_2,B1G018,B1G095,A1G023,B2G026,B1G057,M1 G039, A1G019,A1F018,A2G021_2,A2G017	(1500x900x650) (L x H x W) mm	6
16	Wash Tub Tech Spec Ref.No. HLL/PIC/SS-FRN 14 & 29	B2G054,B1G035,M1_Misc_2,B1G077_2,B1G057,F1G032,A1G023,A1F02 2,A2G017	(2000x900x650) (L x H x W) mm	5
17	Pallet Tech Spec Ref.No. HLL/PIC/SS-FRN 15	F1G013_4,F1G014_3,F1G015_6F1G025,F1G028,M1G012,M1G024,F1G02 3_2,F1G025_2,F1G029,F1G030,F1G024_2	(2500x650x900) (L x W x H) mm	11
18	Platform trolley Tech Spec Ref.No. HLL/PIC/SS-FRN 16	B1G045,F1G055,F1G013_2,F1G019,F1G025_2,F1G032_2,A1G016,B1G0 48,B1G070,B1G041,B1G032,B1G077,F1G023_2,F1G027,F1G066,M1G028, M1G029,M1G033,M1G037,M1G038,A1G0 x 2,A1F018,A1F019,A2G012,B2G027,B2G039_2,B2G048,B2G054,AB_2, Miscellaneous,A2G006,A2G024,W1B_2	(1000x1200x150) (L x W x H) mm	25
19	Trolley-Closed type with removable shelves Tech Spec Ref.No. HLL/PIC/SS-FRN 17	B2G009,M_ Miscellaneous,AE_ Miscellaneous,D_ Misc,P_ Misc,F_ Misc	(1000x900x600) (L x H x W) mm	6
20	SS Janitor Closet Tech Spec Ref.No. HLL/PIC/SS-FRN 18	B1G039,B1G040,B1G070A,B1G082B2G045,B2G057,F1G021,F1G049A,M 1G015,M1_Misc,A1_Misc,A2_Misc,W1B	(600X500X2000) (L x W x H) mm	13
21	Floor Cleaning trolley Tech Spec Ref.No. HLL/PIC/SS-FRN 19	B1G039,B1G040,B1G070A,B1G082,B2G045,B2G057,F1G021,F1G049A, M1G015,M1_Misc,A1_Misc,A2_Misc,W1B	1200X600X1000 (LXWXH) mm	13







22	Glove Box Tech Spec Ref.No. HLL/PIIC/SS-FRN 20	D & P Miscellaneous_9,B2G019,B2G022,B2G026,B2G027,B2G028,B2G039,,B2G043,,B2G030,M1G022,M1G028,M1G029,,M1G033,M1G037,M1G038,A1G013,A1G016,A1F012,A1F013,A1F015,A1F022,A2G009,A2G010,A2G016,A2G017,A2G018,A2G019,A2G021,B1G008,F_ Miscellaneous_8,B1G047_8,A1G018,A1F017,A2G020.	(300x150x150) (L x WxH) mm	56
23	Register stand Tech Spec Ref.No. HLL/PIIC/SS-FRN 21	D& P Miscellaneous_10,B2G001,B2G026,,B2G027,B2G028,B2G039,B2G043,B2G053,M1G012,M1G014,M1G025,M1G022,M1G028,M1G029,M1G033,M1G037,M1G038,A1G013,A1F012,A1F013,A1F015,A1F022,A2G009,A2G010,A2G016,A2G017,A2G018,A2G019,A2G021,B1G008,F_ Miscellaneous_13,B2G030,B1G047_9.	450 (L)x400 (D)x1100 (H) mm	63
24	Settle plate stand Tech Spec Ref.No. HLL/PIIC/SS-FRN 22	D& P Miscellaneous_15,B2G027,B2G039,B2G043,M1G012,M1G014,M1G025,M1G022,M1G028,M1G029,M1G033,M1G037,M1G038,F_ Miscellaneous_20,Miscellaneous_4,B1G008_4,B2G028_12,B1G047_15.	300 (L) x 300 (W) x 600-650 (H) mm	83
25	SOP Stand Tech Spec Ref.No. HLL/PIIC/SS-FRN 23	D& P Miscellaneous_15,B2G026,B2G027,B2G028,B2G039,B2G043,B2G053,M1G022,M1G028,M1G029,M1G033,M1G037,M1G038,A1G013,A1G016,A1F012,A1F013,A1F015,A1F022,A2G009,A2G010,A2G016,A2G017,A2G018,A2G019,A2G021,B1G008,F_ Miscellaneous_31,B1G028_5,B2G051_3,B1G077_12.	Each to hold 20 nos. of A4 laminated papers	102
26	SS Tray Tech Spec Ref.No. HLL/PIIC/SS-FRN 24	D& P Miscellaneous_5,B2G019,B2G022,B2G026,B2G027,B2G028,B2G039,B2G043,M1G022,M1G025,,2,M1G029,,2,M1G033,,2,M1G037,M1G038,A,G013,A1G016,A1F012,A1F013,A1F015,A1F022,A2G009,A2G010,A2G016,A2G017,A2G018,A2G019,A2G021,F_ Miscellaneous_7,B1G047,B1G047_5	400x300x50 (LxWxH) mm	43
27	Step Stool Tech Spec Ref.No. HLL/PIIC/SS-FRN 25	F1G023_3,F1G055,A1G013,A1G016,A1F012,A1F013,A2G009,A2G010,A2G018,W1B_3,B2G043_2	600X600X600 (LXWXH)	16
28	Staining Chamber Tech Spec Ref.No. HLL/PIIC/SS-FRN 26	M1G028,M1G029,B1G018,B2G026,B1G057,	300x300x100 (LxWxH)	5
29	Stool (Revolving + Height adjustable) Tech Spec Ref.No. HLL/PIIC/SS-FRN 27	M1G012_2,M1G022,M1G025,M1G028,M1G029,M1G033,M1G038A1G013,A1F012,A1F014,A2G009,A2G010,A2G016,A2G017,A2G018,A2G019,A2G021_2,B1G008,Miscellaneous_2,B1G009,B1G014,B1G028,B1G038,M1G037,A2G011,B2G043_2	325 (D) x500 (H) mm	30
30	Mobile Sink Tech Spec Ref.No. HLL/PIIC/SS-FRN 28	A1G013,A1G016,A1F013,A1F014,A2G009,A2G010,A2G016,A2G018,A2G019,A2G021,	450x450x1500 (LxWxH)	10
31	Open Trolley Tech Spec Ref.No. HLL/PIIC/SS-FRN 30 Office Cupboard and Eye washer	M1G022,M1G028,M1G029,M1G033,M1G037,M1G038,M1_Misc_2,A1F022,W1B_2,B2G039_2,F1_Misc_2,B1_Misc_2	Refer drawing	17
32	Tech Spec Ref.No. HLL/PIIC/SS-FRN 31	D,P,T,F,MB_2,AE,AB,WH,	Refer drawing	9

7	Lockers Tech Spec Ref.No. HLL/PIIC/SS-FRN 7	900 (L) x 400 (D) x 1800 (H) - 15 Lockers	49						
8	Rack Tech Spec Ref.No. HLL/PIIC/SS-FRN 8	(1500x500x1800) (LxWxH)	62						
		(2500x500x1800) (L x W x H)							
9	Rack - 2 tier Tech Spec Ref.No. HLL/PIIC/SS-FRN 8	(3700x500x1800) (L x W x H)	4						
		(1500x500x1800) (L x W x H)	3						
		(5500x500x1800) (L x W x H)	3						
		(3400x500x1800) (L x W x H)	1						
		(1500x500x1800) (L x W x H)	5						
10	Cold Room Racks Tech Spec Ref.No. HLL/PIIC/SS-FRN 8	(5800x500x1800) (L x W x H)	5						
		(7800x500x1800) (L x W x H)	1						
		(1500x500x1800) (L x W x H)	22						
		(6400x500x1800) (L x W x H)	2						
		(300x600) (D x H)	25						
11	Shoe bin Tech Spec Ref.No. HLL/PIIC/SS-FRN 9	(300x600) (D x H)	25						
12	Shoe rack with exhaust Tech Spec Ref.No. HLL/PIIC/SS-FRN 10	1500 (L) x 350 (W) x 1100 (H) mm	11						
		(2200x900x650) (L x H x W) mm	7						
13	Work Table Tech Spec Ref.No. HLL/PIIC/SS-FRN 11	(1600x900x650) (L x H x W) mm	5						
		(1400x900x650) (L x H x W) mm	6						
		(1800x650x900) (L x W x H) mm	11						
		(1500x650x900) (L x W x H) mm	15						
		(1100x650x900) (L x W x H) mm	74						
14	Work table with drawer Tech Spec Ref.No. HLL/PIIC/SS-FRN 12	(900x450x450)(L x W x H) mm without central sleeves	6						
		1100x650x900 (L x W x H) mm	8						
15	Work table with sink Tech Spec Ref.No. HLL/PIIC/SS-FRN 13 & 29	(1500x900x650) (L x H x W) mm	6						
		(2000x900x650) (L x H x W) mm	5						
16	Wash Tub Tech Spec Ref.No. HLL/PIIC/SS-FRN 14 & 29	(2500x650x900) (L x W x H) mm	11						
17	Pallet Tech Spec Ref.No. HLL/PIIC/SS-FRN 15	(1000x1200x150) (L x W x H) mm	25						
18	Platform trolley Tech Spec Ref.No. HLL/PIIC/SS-FRN 16	(1000x900x600) (L x H x W) mm	32						
19	Trolley-Closed type with removable shelves Tech Spec Ref.No. HLL/PIIC/SS-FRN 17	(1000x900x600) (L x H x W) mm	6						

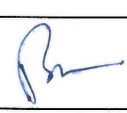
20	SS Janitor Closet Tech Spec Ref.No. HLL/PIIC/SS-FRN 18	(600X500X2000) (L x W x H) mm	13								
21	Floor Cleaning trolley Tech Spec Ref.No. HLL/PIIC/SS-FRN 19	1200X600X1000 (LxWxH) mm	13								
22	Glove Box Tech Spec Ref.No. HLL/PIIC/SS-FRN 20	(300X150X150) (L x WxH) mm	56								
23	Register stand Tech Spec Ref.No. HLL/PIIC/SS-FRN 21	450 (L)x400 (D)x1100 (H) mm	63								
24	Settle plate stand Tech Spec Ref.No. HLL/PIIC/SS-FRN 22	300 (L) x 300 (W) x 600-650 (H) mm	83								
25	SOP Stand Tech Spec Ref.No. HLL/PIIC/SS-FRN 23	Each to hold 20 nos. of A4 laminated papers	102								
26	SS Tray Tech Spec Ref.No. HLL/PIIC/SS-FRN 24	400x300x50 (LxWxH) mm	43								
27	Step Stool Tech Spec Ref.No. HLL/PIIC/SS-FRN 25	600X600X600 (LxWxH)	16								
28	Staining Chamber Tech Spec Ref.No. HLL/PIIC/SS-FRN 26	300x300x100 (LxWxH)	5								
29	Stool (Revolving + Height adjustable) Tech Spec Ref.No. HLL/PIIC/SS-FRN 27	325 (D) x500 (H) mm	30								
30	Mobile Sink Tech Spec Ref.No. HLL/PIIC/SS-FRN 28	450x450x1500 (LxWxH)	10								
31	Open Trolley Tech Spec Ref.No. HLL/PIIC/SS-FRN 30	Refer drawing	17								
32	Office Cupboard and Eye washer Tech Spec Ref.No. HLL/PIIC/SS-FRN 31	Refer drawing	9								

LIST OF ATTENDEES

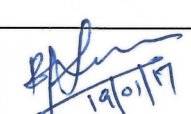
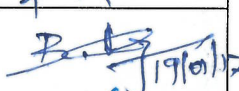
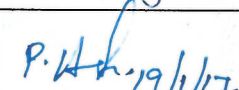
Subject : Pre Bid meeting for Supply and Installation of Stainless Steel (SS) Furniture at PII- Coonoor
Date & Time : 19.01.2017 @ 11.00 Hrs.
Venue : HBL Corporate Office

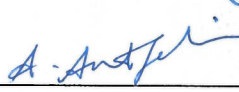
S.NO	Name & Designation	Organization	Contact No	Signature
1	P. Sathya Vignesh Sr. Sales Engineer	Citizen Industries	9099989012	
2	Dr. N. Sivaranda (ARD)	PIIC	9486921166	
3	K. MURTHY	PUC	9626209291	
4	T. Lalitha	PIIC	9443091544	
5	R. MOHAN	PIIC	9790326511	
6	B. ANNAMALAI	PIIC	9443809913	
7	PASHOK.	SICC	9790900141	
8	VISHNU. J	HBL	8939800325	
9	Anto Felix	HBL	8939800312	
10	S. Pandiyar	HBL	9751557706	