

HLL LIFECARE LIMITED
(A Government of India Enterprise)
CENTRAL ENGINEERING DIVISION
PEROORKADA.P.O,
THIRUVANANTHAPURAM - 695 005
KERALA, INDIA

TECHNICAL BID

**SUPPLY OF CONVEYOR CHAIN ASSEMBLY &
SPROCKET FOR CONVEYOR TYPE ELECTRONIC
TESTING MACHINE**

IFB No: HLL/CED/PFT/CET/BO- CHAIN & SPROCKET/2016

Date : 15-06-2016

CONTENTS

| Sl. No | Description | Page No |
|---------------|-----------------------------------|----------------|
| 1 | Certificate of Confidentiality | 2 |
| 2 | Technical Bid Information | 3 |
| 3 | Pre-Qualification Criteria | 3 |
| 4 | Application for Pre-Qualification | 5 - 6 |
| 5 | Annexure-I | 8 |
| 6 | Annexure-II | 9 |
| 7 | Annexure-III | 10 |
| 8 | Annexure-IV | 11 |
| 9 | Annexure-V | 12 |
| 10 | Annexure-VI | 13 |
| 11 | Check List | 14 |

CERTIFICATE OF CONFIDENTIALITY

We understood that HLL Lifecare Limited is the sole owner of the technology and equipment specification & drawings given to us. We hereby certify that the details given to us will be kept confidential and will not be used for any other purpose or transferred to third party.

SIGNATURE (S) OF BIDDER

(To be submitted in the letter pad of the firm indicating full name and address, telephone & fax numbers etc.)

TECHNICAL BID

1. Bid Information

1.1 The Technical Bid must include the following information;

- a. Proposed period of Completion.
- b. All information requested in the bidding document.
- c. The details specified under Technical bid evaluation criteria.

2. PRE-QUALIFICATION CRITERIA

These sheets should be filled up after reading the complete bidding document and the relevant details asked for detailed as below should be enclosed with this bid.

- 2.1. Bidders should have minimum 5 years experience in the relevant field and should have successfully completed the supply of conveyor chain / sprocket, each costing not less than Rs.10 lakhs during the last 5 years.
- 2.2. Average annual financial turnover of the bidder during the last 3 years, ending 31st March of the previous financial year, should be at least Rs.50 Lacs
- 2.3 The supplier should have their own casting facility. HLL reserves the right to visit this facility of the L1 party before placing the order.
- 2.4 Casting material chemical composition will have to be ensured in the presence of HLL Engineer. Only after the approval from HLL engineer , the party can start casting.
- 2.5 HLL reserves the right to do third party material inspection from NABL accredited Material testing labs/ CMERI/IISC/IIT and if any discrepancy noted, HLL reserves the right to cancel the order.
- 2.3. The list of major similar jobs executed satisfactorily in last five years, giving details of type of work, name & address of client, value of job & duration including photos and copies of major orders with completion certificate from the client
- 2.4. Earnest Money Deposit in the manner specified.
- 2.5. Power of Attorney in case an authorized representative has signed the tender.
- 2.6. The duly signed acceptance form conforming that All terms & conditions, technical specifications, drawings & volume of job are understood by the bidder. Certificate that bid is in total conformity with the specifications and terms and conditions mentioned in the bid document and certificate on period of validity (sheet enclosed)
- 2.7. Deviation if any, giving reasons for the deviation.
- 2.8. List of Plant & Machinery, tools & tackles available with the contractor and intended to be used in the said job to be filled in the enclosed sheet.

- 2.9. Total list of technical staff, labour (skilled & unskilled) intended to be deployed in the said job to be filled in the enclosed sheet.
- 2.10. Information regarding projects in hand
- 2.11. Information regarding bidder such as Litigation, orders regarding expulsion or black listing, if any
- 2.12. Even though the bidder meet the above qualifying criteria, they are subject to be disqualified if they have a record of poor performance such as abandoning the works, not properly completing the contract, inordinate delays in completion, litigation history, or financial failures etc.
- 2.13. Assurance that the Contractor shall take insurance policy as mentioned in the bid jointly in the name of HLL and the Contractor, valid till completion of the awarded work.
- 2.14. HLL Lifecare Limited is the sole owner of the technology and equipment specification & drawings given along with the bidding document and drawings to be given to the Contractor. The details given to bidders and Contractor should be kept confidential and should not be used for any other purpose or should not be transferred to third party. The bidders should certify that the information given to them will not be used for any other purpose.
- 2.15. In addition to the above, HLL will evaluate the technical knowledge, fabrication facility and the potential of the party to undertake the work. The decision of HLL will be final and binding.

Note: - HLL does not bind itself to accept the lowest or any tender, and reserves to itself the right to accept or reject any or all the tenders, either in whole or in part without assigning any reason for doing so.

The list of major similar jobs executed satisfactorily in last five years, giving details of type of work, name & address of client, value of job & duration including photos and copies of major orders with completion certificate from the client shall also be enclosed.

Note: Details to be furnished in **Annexure I**

E. Information regarding projects in hand Note: Details to be furnished in **Annexure II**

F. Average annual financial turn over of the bidder during the last 3 years, ending 31st March of the previous financial year, should be at least Rs. 50 Lakhs

a. Annualized turn over of the Contractor/Firm/Company in the last 3 years ending 31.03.2016

1. 2013 – 2014: INR.

2. 2014 – 2015: INR.

3. 2015 - 2016: INR.

Note: Details to be furnished in **Annexure III**

G. Has the Contractor/ Firm/Company ever been black listed by the Govt /or the registering authority.

i) If so, give the period and details.

H. Completion Period: in **Annexure V** (filled and enclosed)

I. Acceptance Form in **Annexure VI**

J. CERTIFICATE for authenticity of information provided with Offer as per **Annexure VII**

I/We hereby certify that the details given in the application form and Annexure I to Annexure VIII are correct to the best of my/our knowledge. I /We have no objection, in Owner (HLL Lifecare Limited) contacting any of our clients for reference.

Signature

Name and address of the Party

Place:

Date:

ANNEXURE - I

LIST OF SIMILAR CASTING JOBS EXECUTED DURING THE LAST FIVE YEARS

| SL.NO | DETAILS OF WORK | CONTRACT VALUE (In Lakhs) | NAME & ADDRESS OF CLIENT | COMPLETION TIME AS PER ORDER (In months) | ACTUAL TIME TAKEN |
|-------|-----------------|---------------------------|--------------------------|--|-------------------|
| 1 | | | | | |
| 2 | | | | | |
| 3 | | | | | |
| 4 | | | | | |
| ... | | | | | |

SIGNATURE OF BIDDER

Note:- Bidders should have executed successfully two fabrication works, each work costing not less than Rs.10lakhs, during the last 5 years. Enclose 2 completion certificates from the clients certified that similar fabrication works costing not less than Rs.10 Lakhs are completed satisfactorily

ANNEXURE-II

| DETAILS OF ONGOING PROJECTS | | | |
|------------------------------------|--|--|----------------|
| Sl. No. | Name of Client with full address, telephone numbers and nature of work | Order details such as quantity, completion time etc. | Value of works |
| 1 | | | |
| 2 | | | |
| 3 | | | |
| 4 | | | |

ANNEXURE III

(ENCLOSE DETAILS OF ANNUALISED TURN OVER OF THE CONTRACTOR/FIRM/COMPANY IN THE LAST 3 YEARS ENDING 31-03-2016)

2013 - 2014: INR.

2014- 2015: INR.

2015 - 2016: INR.

(Enclose audited Balance sheets in proof for the above period)

Note: Average annual financial turn over of the bidder during the last 3 years, ending 31st March of the previous financial year, should be at least INR 50 Lacs

ANNEXURE – IV
COMPLETION PERIOD

SIGNATURE OF THE BIDDER WITH SEAL

Note: - The bidder should complete the subjected work within a period of **6WEEKS** from the date of receipt of confirmed order.

ANNEXURE-V

ACCEPTANCE FORM

(To be submitted in the letter pad of the firm indicating full name and address, telephone & fax numbers etc.)

From

To

Deputy Chief Engineer,
Central Engineering Division,
HLL Lifecare Limited (A Government of India Enterprise),
Peroorkada, Thiruvananthapuram – 691005, Kerala State,
India
Phn: (++91 471) 2433374,2437270 – 501, 502, 503
Tele Fax: (++ 91 471) 2432647
E-mail: rajeevrv@lifecarehll.com, krknair@lifecarehll.com

Dear Sir,

I / We, hereby offer to fabricate/assemble/lead/install/integrate/test/commission as detailed in schedule hereto or such portion thereof as you may specify in the acceptance of Bid at the price given in the price bid and agree to hold this offer open till 90 days after the date of bid opening prescribed by the Owner. I/We have understood the terms and conditions mentioned in the invitation for bid and Conditions of Contract furnished by you and have thoroughly examined the specifications quoted in the bid document hereto and are fully aware of the nature of the scope of work required and my/our offer is to comply strictly in accordance with the requirement and the terms and conditions mentioned above. I/We have understood that the OWNER is the sole owner of the technology, equipment, specification and drawings given along with the bidding documents. I/we here by assure that the above information will be kept confidential and will not be used for any other purpose or will not be transferred to third party.

Yours faithfully,

SIGNATURE OF THE BIDDER

ANNEXURE VI

CERTIFICATE FOR AUTHENTICITY OF INFORMATION

I / we hereby certify that the information given with this bidding document is correct. If, at any stage, it is found to be incorrect, I / we understand that the contract will be liable to be terminated and action could be taken against me/us by the Company for damages.

SIGNATURE (S) OF BIDDER WITH SEAL

(To be submitted in the letter pad of the firm indicating full name and address, telephone & fax numbers etc.)

CHECKLIST FOR TECHNICAL BID

| SI NO | PARTICULARS | ATTACHED (YES/NO) |
|--------------|---|------------------------------|
| 1. | EMD as prescribed in the Tender | |
| 2. | Certificate of Confidentiality | |
| 3. | Application for Pre-Qualification duly filled | |
| 4. | Annexure I | |
| 5. | Annexure II | |
| 6. | Annexure III | |
| 7. | Annexure IV | |
| 8. | Annexure V | |
| 9. | Annexure VI | |

**HLL LIFECARE LIMITED,
CENTRAL ENGINEERING DIVISION
PEROORKADA FACTORY,
THIRUVANANTHAPURAM – 695 005,
KERALA, INDIA.
Phn: 0471 – 2433374, 2437270**

PRICE BID

**SUPPLY OF CONVEYOR CHAIN ASSEMBLY AND SPROCKET
FOR CONVEYOR TYPE ELECTRONIC TESTING MACHINE**

IFB No. : HLL/CED/PFT/CET /BO-CHAIN&SPROCKET/2016

DATE : 15-06-2016

| | | |
|---|---|---------------------|
|  | HLL LIFECARE LIMITED (A Government of India Enterprise) CENTRAL ENGINEERING DIVISION PEROOKADA PO, THIRUVANANTHAPURAM- 695 005, KERALA, INDIA Phn: 0471 – 2437270, 2433374 | |
| | TENDER FOR THE SUPPLY OF CONVEYOR CHAIN ASSEMBLY AND SPROCKET FOR CONVEYOR TYPE ELECTRONIC TESTING MACHINE (10 STATION ET MACHINE) | |
| PLANT: PFT | REF: IFB No.HLL/CED/PFT/CET/BO- CHAIN&SPROCKET/2016 | DATE :15.06.2016 |

INVITATION FOR BIDS (IFB)

IFB No : HLL/CED/PFT/CET/BO-CHAIN&SPROCKET/2016

DTAE : 15-06-2016

HLL Lifecare Limited (HLL), a Government of India Enterprise is in the process of fabricating Conveyor Type Electronic Testing Machine for testing male condoms. For the said project, sealed and super scribed bids are invited from competent and experienced Suppliers/Contractors who are capable to do the following work meeting the requirements as per our tender.

| Sl. No | Brief Description of Item/Work | Qty | EMD |
|--------|---|-----------------------|-------------|
| 1 | Supply of Conveyor chain assembly and Sprocket with shaft as per drawing no.HLL- D-251-00 for Conveyor Type Electronic Testing Machine as per drawing no. HLL-D-136-00 and tender specifications at HLL, Peroorkada Factory, Thiruvananthapuram | As per Schedule IV | Rs.10,000/- |

2. The bid documents will be available up to 15.00 Hrs. on the previous working day of the opening of the bids.
3. The Tender Documents can also be downloaded from our Website www.lifecarehll.com from the date of issue of tender document. Tender forms shall be filled in ink or typed. No tender filled in pencil shall be considered. The tenderer shall sign and seal the form at each page and at the end, in token of acceptance of all the terms and conditions of the tender. Any subsequent changes/amendments will be published only in our website
4. The scheduled date for issue, receipt and opening of bids is as follows.
 - a) Date of issue of tender document - 15-06-2016 onwards
 - b) Last date and time for receipt of bids - 25-06-2016 up to 15.00 Hrs.
 - c) Date and time of opening of bids - 25-06--2016, 15.30 Hrs.
 - d) Address for communication, receipt and place of opening of bids:

Deputy Chief Engineer (CED)
Central Engineering Division,
HLL Lifecare Limited (A Government of India Enterprise),
PB No 2, Peroorkada, Thiruvananthapuram – 695005,
Kerala State, India
Ph: (++91 471) 2433374,2437270 –501,502,503
E-mail: rajeevrv@lifecarehll.com, krknair@lifecarehll.com

| | | |
|---|---|---------------------|
|  | HLL LIFECARE LIMITED (A Government of India Enterprise) CENTRAL ENGINEERING DIVISION PEROOKADA PO, THIRUVANANTHAPURAM- 695 005, KERALA, INDIA Phn: 0471 – 2437270, 2433374 | |
| | TENDER FOR THE SUPPLY OF CONVEYOR CHAIN ASSEMBLY AND SPROCKET FOR CONVEYOR TYPE ELECTRONIC TESTING MACHINE (10 STATION ET MACHINE) | |
| PLANT: PFT | REF: IFB No.HLL/CED/PFT/CET/BO- CHAIN&SPROCKET/2016 | DATE :15.06.2016 |

2. The completed and sealed bid documents and all schedules should be submitted to Deputy Chief Engineer(CED) in the above address
3. The completed and sealed bid documents along with the EMD should be submitted to **Deputy Chief Engineer(CED)**, in the above address. Bids received after due date and time will be rejected. Any bid not accompanied by EMD will be rejected
5. The outer cover should bear the Enquiry No, closing date and General description of item tendered, and the words "DO NOT OPEN BEFORE" 15.30 Hrs (IST) on ----- (Indicate the Closing Date).
6. Bids will be opened in the presence of Bidders representative(s) who choose to attend on the specified date and time, at the office of HLL at the address given in Clause 2 (d) above.
7. In the event of the date specified for bid receipt and opening being declared as a closed holiday for the above purchaser's office, the due date for submission of bids and opening of bids will be the following working day at the appointed times.
8. HLL may, at its discretion, extend this deadline for submission of bids by amending the Bid Documents or any other reasons, in which case all rights and obligations of HLL and Bidders previously subject to the deadline will thereafter be subject to the deadline as extended.
9. HLL will not be held responsible for the postal delay, if any, in the delivery of the bidding document or the non-receipt of the same. Bids sent by Telex/Fax/Telegraph will not be accepted.
10. The company reserves the right to club or split the items of works, change the qualifying criteria at their discretion and to reject or cancel the Invitation for bids without assigning any reason thereof.
11. In addition to the invitation for bids, the bidding documents include the following schedules.

| | | |
|----------|-------|----------------------------------|
| SCHEDULE | - I | : Conditions of Bid |
| SCHEDULE | - II | : Detailed Specification of Item |
| SCHEDULE | - III | : Conditions of Contract |
| SCHEDULE | - IV | : Format of Quoting |
| SCHEDULE | - V | : Acceptance Form |

DEPUTY CHIEF ENGINEER (CENTRAL ENGINEERING DIVISION)

| | | |
|---|---|---------------------|
|  | HLL LIFECARE LIMITED (A Government of India Enterprise) CENTRAL ENGINEERING DIVISION PEROOKADA PO, THIRUVANANTHAPURAM- 695 005, KERALA, INDIA Phn: 0471 – 2437270, 2433374 | |
| | TENDER FOR THE SUPPLY OF CONVEYOR CHAIN ASSEMBLY AND SPROCKET FOR CONVEYOR TYPE ELECTRONIC TESTING MACHINE (10 STATION ET MACHINE) | |
| PLANT: PFT | REF: IFB No.HLL/CED/PFT/CET/BO- CHAIN&SPROCKET/2016 | DATE :15.06.2016 |

SCHEDULE I

CONDITIONS OF BID

1. Definitions

- a. **“Invitation For Bid”** shall mean and include the present document, and such other complements and agenda, which may subsequently be issued in this connection.
- b. **“Purchaser/Owner”** shall mean HLL Lifecare Limited, (Thiruvananthapuram) or its units thereof.
- c. **“Bidder”** shall mean the person, firm of Corporation submitting a bid against this invitation for bid and shall also include his agents and representatives.
- d. **“Supplier/Contractor”** shall mean the bidder whose bid has been accepted and shall also include his successors and assigns, agents and representatives.
- e. **“Contract”** means signed acceptance of the Letter of Intend, if issued, and order by the supplier.
- f. **“Site”** shall mean **HLL Lifecare Limited, Peroorkada Factory, Thiruvananthapuram – 695005, Kerala**

2. Bid Information and Period of Validity

2.1 The Bid must include the following information,

- a. Enquiry / IFB No.
- b. Promised Delivery Schedule for each item/work.
- c. Certificate that bid is in total conformity with the specifications and terms and conditions mentioned in the bid document and if not, list of exclusions, and/or exceptions.
- d. All information requested in the specifications, dimensional drawings, technical literature describing the make offered, material etc., as specified in the bid document.
- e. The Price should be quoted as per the following:
 - i) The Bidder shall indicate all prices including basic price, the relevant duties and taxes, other levies, packing & forwarding charges, charges for inland transportation and other local costs incidental to delivery of the goods to supplier’s site, etc. on the appropriate price schedule (FORMAT FOR QUOTING – SCHEDULE IV) attached to these documents for completing the above work as per the Specification, Terms and Conditions as specified in the Bid Documents. Civil work is excluded from the scope of the supplier.

| | | |
|---|---|---------------------|
|  | HLL LIFECARE LIMITED (A Government of India Enterprise) CENTRAL ENGINEERING DIVISION PEROOKADA PO, THIRUVANANTHAPURAM- 695 005, KERALA, INDIA Phn: 0471 – 2437270, 2433374 | |
| | TENDER FOR THE SUPPLY OF CONVEYOR CHAIN ASSEMBLY AND SPROCKET FOR CONVEYOR TYPE ELECTRONIC TESTING MACHINE (10 STATION ET MACHINE) | |
| PLANT: PFT | REF: IFB No.HLL/CED/PFT/CET/BO- CHAIN&SPROCKET/2016 | DATE :15.06.2016 |

- ii) Bidder must quote for unit price and total price based on the requirement shown in the bid document.
- iii) Price should be firm without any escalation on any account until the order is completely fulfilled.
- iv) All other documents/certificate/information as specified in the bid document.

2.2 Bids shall remain valid for **90 days** after the date of bid opening prescribed by the Purchaser.

3. Format and Signing of Bid

- 3.1 All pages of the bid, except for un-amended printed literature shall be signed by the person or persons signing the bid.
- 3.2 Bids shall be made in English.
- 3.3 The bid shall contain no interlineations, erasures or overwriting except as necessary to correct errors made by the Bidder, in which case such corrections shall be signed by the person or persons signing the bid.

4. Submission of Bids

Sealing and Marking of Bids

- 4.1 The bids should be submitted in duplicate. The Bidder shall seal the original and each copy of the bid in an inner and then in an outer envelope, duly marked the envelopes as "original" and "copy".
- 4.2 The inner and outer envelopes shall be:
 - (a) Addressed to the Purchaser in the following address,

Deputy Chief Engineer (CED),
HLL Lifecare Limited
Central Engineering Division,
Perookada. PO, Thiruvananthapuram – 695005,
Kerala, India
Phn: 0471 – 2437270, 2433374
E-mail:rajeevrv@lifecarehll.com, krknair@lifecarehll.com
 - (b) Bear the Enquiry No, closing date and General description of item tendered, and the words "DO NOT OPEN BEFORE" 15.30 Hrs (IST) on ----- (Indicate the Closing Date).
- 4.3 The inner envelopes shall indicate the name and address of the Bidder. If the outer envelope is not sealed and marked as indicated above, the Purchaser will assume no responsibility for the bid's misplacement or premature opening.

| | | |
|---|---|---------------------|
|  | HLL LIFECARE LIMITED (A Government of India Enterprise) CENTRAL ENGINEERING DIVISION PEROOKADA PO, THIRUVANANTHAPURAM- 695 005, KERALA, INDIA Phn: 0471 – 2437270, 2433374 | |
| | TENDER FOR THE SUPPLY OF CONVEYOR CHAIN ASSEMBLY AND SPROCKET FOR CONVEYOR TYPE ELECTRONIC TESTING MACHINE (10 STATION ET MACHINE) | |
| PLANT: PFT | REF: IFB No.HLL/CED/PFT/CET/BO- CHAIN&SPROCKET/2016 | DATE :15.06.2016 |

4.4 Bids should be hand delivered or sent by courier to ensure timely arrival. Telex, cable, e-mail or facsimile bids will be rejected.

5. Earnest Money

15.1 Each bid must be accompanied by E.M.D.

15.2 The EMD is required to protect the Owner against risk of Bidder's conduct, which would warrant the security's forfeiture

- a. The EMD shall be in the form of Demand Draft from a nationalized bank drawn in favour of HLL Lifecare Limited, Thiruvananthapuram payable at Thiruvananthapuram.
- b. E.M.D. of the unsuccessful bidders will be released after tabulating tenders, keeping only the earnest money of the first three lowest bidders. The earnest money deposit of the remaining two unsuccessful bidders will be released after the acceptance of the notification of award by the successful bidder.
- c. In the case of successful bidder, the Earnest Money will be returned after signing the agreement and submission of Demand Draft towards Security Deposit, which they will have to offer for the faithful execution of the contract.

15.3 The EMD may be forfeited:

- (a) If a Bidder withdraws its bid during the period of bid validity specified by the Bidder on the Bid Document; or
- (b) In case of the successful Bidder, if the Bidder fails:
 - (i) to sign the agreement.
 - (ii) to furnish security deposit.
 - (iii) does not accept the correction of his bid price pointed out by HLL

Deadline for submission of Bids

4.5 The bids will be received by the Purchaser in the above given address (4.2.a) not later than the date and time specified in the Invitation for Bids.

In the event of the specified date for submission of Bids being declared a holiday for the Purchaser, the bids will be received up to the appointed time on the next working day.

4.6 The purchaser may, at its discretion, extend this deadline for submission of bids by amending the Bid Documents or any other reasons in which case all rights and obligations of the Purchaser and Bidders previously subject to the deadline will thereafter be subject to the deadline as extended.

| | | |
|---|---|---------------------|
|  | HLL LIFECARE LIMITED (A Government of India Enterprise) CENTRAL ENGINEERING DIVISION PEROOKADA PO, THIRUVANANTHAPURAM- 695 005, KERALA, INDIA Phn: 0471 – 2437270, 2433374 | |
| | TENDER FOR THE SUPPLY OF CONVEYOR CHAIN ASSEMBLY AND SPROCKET FOR CONVEYOR TYPE ELECTRONIC TESTING MACHINE (10 STATION ET MACHINE) | |
| PLANT: PFT | REF: IFB No.HLL/CED/PFT/CET/BO- CHAIN&SPROCKET/2016 | DATE :15.06.2016 |

- 4.7 It is the responsibility of the bidders to see that the completed bidding documents whether sent by post or by courier or by person are received in the office of **Deputy Chief Engineer(CED)**, in the above address by the date and time stipulated for receipt as above failing which the bid would be considered late and rejected. Purchaser will not be held responsible for the postal delay, if any, in the delivery of the bidding document or the non-receipt of the same. Bids received after due date and time will be rejected. Mere handing over of the bid documents at reception counter or at any other counter or room or person cannot be considered as submission of bid.

6. Clarification of Bidding Documents

A prospective Bidder requiring any clarification of the Bidding Documents may notify the Purchaser in writing, or by fax at the purchasers mailing address indicated in the Invitation for Bids. The Purchaser will respond in writing to any request for clarification of Bidding Documents, which it receives not later than 7 days prior to the deadline for submission of Bids prescribed by the Purchaser.

7. Amendment of Bidding Documents

- 6.1 At any time prior to the deadline for submission of bids, the Purchaser may, for any reason, modify the Bidding Documents by amendment.
- 6.2 The amendment will be notified in writing or fax or telegram or e-mail to all prospective Bidders, which have received the Bidding Documents and will be binding on them.
- 6.3 In order to afford prospective Bidders reasonable time in which to take the amendment in to account in preparing their bid, the Purchaser may, at its discretion, extend the deadline for the submission of bids.

8. Bid Opening by Purchaser

- 7.1 The Purchaser will open bids, in the presence of the bidders' representatives who choose to attend, at the date and time specified and in the location given in this document. The Bidders' representatives who are present shall sign a register evidencing their attendance. In the event of the specified date of bid opening being declared a holiday for the Purchaser, the bids shall be opened at the appointed time and location on the next working day.
- 7.2 The Purchaser will prepare appropriate bid opening register and the same shall be signed by bidders present during the opening of the bids and Purchaser.

| | | |
|---|---|-----------------------------------|
|  | HLL LIFECARE LIMITED (A Government of India Enterprise) CENTRAL ENGINEERING DIVISION PEROOKADA PO, THIRUVANANTHAPURAM- 695 005, KERALA, INDIA Phn: 0471 – 2437270, 2433374 | |
| | TENDER FOR THE SUPPLY OF CONVEYOR CHAIN ASSEMBLY AND SPROCKET FOR CONVEYOR TYPE ELECTRONIC TESTING MACHINE (10 STATION ET MACHINE) | |
| PLANT: PFT | REF: IFB No.HLL/CED/PFT/CET/BO- CHAIN&SPROCKET/2016 | DATE :15.06.2016 |

9. Clarification of bids

To assist in the examination, evaluation and comparison of bids, the purchaser may, at its discretion, ask the bidder for a clarification of its bid. The request for clarification and the response shall be in writing and no change in the price or substance of the bid shall be sought, offered or permitted.

10. Preliminary examination

- 9.1 The purchaser will examine the bids to determine whether they are complete, whether any computational errors have been made, whether the documents have been properly signed, whether the bid validity is as required and whether the bids are generally in order.
- 9.2 Arithmetical errors will be rectified on the following basis. If there is a discrepancy between the unit price and the total price that is obtained by multiplying the unit price and quantity, the unit price shall prevail and the total price shall be calculated. If there is a discrepancy between the words and figures, the amount in words shall prevail.
- 9.3 Prior to the detailed evaluation, the purchaser will determine the substantial responsiveness of each bid to the bidding documents. For purposes of these clauses, a substantially responsive bid is one that conforms to specifications and all the terms and conditions of the bidding documents without material deviation. The purchaser's determination of a bid's responsiveness is to be based on the contents of the bid itself without recourse to extrinsic evidence.
- 9.4 A bid determined as not substantially responsive will be rejected by the purchaser and may not subsequently be made responsive by the bidder by correction of the non-conformity.
- 9.5 The purchaser may waive any minor informality or non-conformity or irregularity in a bid, which does not constitute a material deviation, provided such waiver does not prejudice or affect the relative ranking of any bidder.
- 9.6 The purchaser's determination as to the substantial responsiveness or otherwise of each bid or consideration of a minor informality or non-conformity or irregularity is final and conclusive.

11. Evaluation and comparison of bids.

- 10.1 The purchaser will technically evaluate all bids previously determined to be responsive and compare the bids previously determined to be substantially responsive and technically acceptable.

| | | |
|---|---|---------------------|
|  | HLL LIFECARE LIMITED (A Government of India Enterprise) CENTRAL ENGINEERING DIVISION PEROOKADA PO, THIRUVANANTHAPURAM- 695 005, KERALA, INDIA Phn: 0471 – 2437270, 2433374 | |
| | TENDER FOR THE SUPPLY OF CONVEYOR CHAIN ASSEMBLY AND SPROCKET FOR CONVEYOR TYPE ELECTRONIC TESTING MACHINE (10 STATION ET MACHINE) | |
| PLANT: PFT | REF: IFB No.HLL/CED/PFT/CET/BO- CHAIN&SPROCKET/2016 | DATE :15.06.2016 |

11. Post – qualification

- 11.1 Notwithstanding the qualification requirements given in this document, the Purchaser will determine to its satisfaction whether the Bidder selected as having submitted the lowest evaluated responsive bid is qualified to satisfactorily perform the Contract.
- 11.2 The determination will take into account the Bidder's financial, technical and production capabilities. It will be based upon an examination of the documentary evidence of the Bidder's qualifications submitted by the Bidder, as well as such other information as the Purchaser deems necessary and appropriate.
- 11.3 The Purchaser reserves the right to negotiate with the lowest evaluated responsive bidder.
- 11.4 An affirmative determination will be a prerequisite for award of the Contract to the Bidder. A negative determination will result in rejection of the Bidder's bid, in which event the Purchaser will proceed to the next lowest evaluated bid to make a similar determination of that bidder's capabilities to perform satisfactorily.
- 11.5 Conditional Bids shall not be entertained.

12. Award Criteria

The Purchaser will award the Contract to the successful Bidder whose bid has been determined to be substantially responsive and has been determined as the lowest evaluated bid provided further that the Bidder is determined to be qualified to perform the Contract satisfactorily for the items offered.

13. Notification of Award

- 13.1 Prior to the expiration of the period of bid validity, the purchaser will notify the successful Bidder in writing by post or by cable or telex or fax, to be confirmed in writing by post, that its bid has been accepted. The notification of award may be sent in the form of Letter of Intend / Work order.
- 13.2 The signed acceptance of the notification of award by the Supplier/Contractor will constitute a concluded contract.

| | | |
|---|---|---------------------|
|  | HLL LIFECARE LIMITED (A Government of India Enterprise) CENTRAL ENGINEERING DIVISION PEROOKADA PO, THIRUVANANTHAPURAM- 695 005, KERALA, INDIA Phn: 0471 – 2437270, 2433374 | |
| | TENDER FOR THE SUPPLY OF CONVEYOR CHAIN ASSEMBLY AND SPROCKET FOR CONVEYOR TYPE ELECTRONIC TESTING MACHINE (10 STATION ET MACHINE) | |
| PLANT: PFT | REF: IFB No.HLL/CED/PFT/CET/BO- CHAIN&SPROCKET/2016 | DATE :15.06.2016 |

SCHEDULE II

DETAILED SPECIFICATION OF ITEM

Requirement:

We are in the process of fabricating Conveyor Type Electronic Testing Machine at our Peroorkada Factory, Thiruvananthapuram for testing male condoms. For the proposed machine, we require the following item as per the specifications given below:

Technical Data and Specification

1. SPROCKET

| SL NO. | ITEM/DESCRIPTION | DRAWING NO. | MATERIAL | QUANTITY |
|--------|--------------------|----------------------|--|----------|
| 1. | SPROCKET | HLL-D-251-00 | Steel Casting CS-125 IS-1030-1962 | 4Nos. |
| 2. | SHAFT | HLL-D-251-00 | EN 24 HRC 52 | 2Nos. |
| 3. | GIB HEADED KEY | HLL-D-251-00 | EN8 Hardened and Tempered IS-2293-1974 | 4Nos. |
| 4. | PARALLEL KEY | HLL-D-251-00 | EN8 Hardened and Tempered IS-2048 | 1No. |
| 5. | STOPPER KEY | HLL-D-251-00 | EN8 Hardened and Tempered | 4Nos. |
| 6. | SPACER | HLL-CED-D2-60- 00 | Mild Steel IS 2062 | 2Nos. |
| 7. | M8 NUT | Std. item | Mild Steel IS 2062 | 4Nos. |
| 8. | M8X50mm SHD Bolt | Std. item | Mild Steel IS 2062 | 4Nos. |
| 9. | M8SPRING WASHER | Std. item | Mild Steel IS 2062 | 4Nos. |
| 10. | M8 PLANE WASHER | Std. item | Mild Steel IS 2062 | 8Nos. |

| | | |
|---|---|---------------------|
|  | HLL LIFECARE LIMITED (A Government of India Enterprise) CENTRAL ENGINEERING DIVISION PEROOKADA PO, THIRUVANANTHAPURAM- 695 005, KERALA, INDIA Phn: 0471 – 2437270, 2433374 | |
| | TENDER FOR THE SUPPLY OF CONVEYOR CHAIN ASSEMBLY AND SPROCKET FOR CONVEYOR TYPE ELECTRONIC TESTING MACHINE (10 STATION ET MACHINE) | |
| PLANT: PFT | REF: IFB No.HLL/CED/PFT/CET/BO- CHAIN&SPROCKET/2016 | DATE :15.06.2016 |

2. CHAIN

Technical Data and Specification

| | | |
|------------|---|----------------------------|
| Item | : | Conveyor Chain Assembly |
| Quantity | : | 52 Metres |
| Drawing No | : | HLL-D-136-00 |
| Make | : | TSUBAKI/TI DIAMOND/TRIPCON |

MANDATORY CONDITIONS

1. The supplier should have their own casting facility. HLL reserves the right to visit this facility of the L1 party before placing the order.
2. Casting material chemical composition will have to be ensured in the presence of HLL Engineer. Only after the approval from HLL engineer, the party can start casting.
3. HLL reserves the right to do third party material inspection from NABL accredited material testing labs/ CMERI/IISC/IIT and if any discrepancy noted, HLL reserves the right to cancel the order.

GENERAL CONDITIONS

- 1) Given specification are indicative only. The supplier should visit the HLL Site at Peroorkada Factory, Thiruvananthapuram and see the machines and also take their own assessments before quoting of bids. Prior permission from HLL shall be taken for visiting the plant. No photographs will be allowed inside the plant. The purchaser will not be responsible for any wrong quotes due to inadequate information.
- 2) The supplier should submit 3 copies of the following documents relevant to his scope of work, two weeks prior to the commissioning of the unit, free of cost.
 1. Instruction/Testing/Operation manual (3 copies)
 2. Maintenance manual/Lubrication Chart (3 copies)
 3. All final drawings - Electrical, mechanical and civil (3 copies)
 4. Relevant Test Certificates, Guarantee Certificate for each item of equipment.
 5. Catalogue and literature on bought outs (3 copies)
 6. Any other related documents

| | | |
|---|---|---------------------|
|  | <p align="center">HLL LIFECARE LIMITED (A Government of India Enterprise) CENTRAL ENGINEERING DIVISION PEROOKADA PO, THIRUVANANTHAPURAM- 695 005, KERALA, INDIA Phn: 0471 – 2437270, 2433374</p> | |
| | <p align="center">TENDER FOR THE SUPPLY OF CONVEYOR CHAIN ASSEMBLY AND SPROCKET FOR CONVEYOR TYPE ELECTRONIC TESTING MACHINE (10 STATION ET MACHINE)</p> | |
| PLANT: PFT | REF: IFB No.HLL/CED/PFT/CET/BO- CHAIN&SPROCKET/2016 | DATE :15.06.2016 |

- 3) The item should be complete with all accessories and interconnections.
- 4) The bidder should attach to their bid detailed specifications, catalogues and other details of all the items quoted by them.
- 5) Calibration certificates with traceability to National Standards shall be supplied for all the instruments coming under the scope of supply of supplier.
- 6) The supplier should submit necessary test certificates as per relevant standards of material used, free of cost.
- 7) The suppliers should submit the following documents, relevant to their scope of work, two weeks prior to the commissioning of the Unit :
 - a) All final drawings
 - b) Relevant Test Certificates, Guarantee Certificate for each material which are using for fabrication.
 - c) Any other related documents
- 8) Any deviations from the bid documents shall be clearly indicated.
- 9) The bid should be complete with all the relevant details.

| | | |
|---|---|---------------------|
|  | HLL LIFECARE LIMITED (A Government of India Enterprise) CENTRAL ENGINEERING DIVISION PEROOKADA PO, THIRUVANANTHAPURAM- 695 005, KERALA, INDIA Phn: 0471 – 2437270, 2433374 | |
| | TENDER FOR THE SUPPLY OF CONVEYOR CHAIN ASSEMBLY AND SPROCKET FOR CONVEYOR TYPE ELECTRONIC TESTING MACHINE (10 STATION ET MACHINE) | |
| PLANT: PFT | REF: IFB No.HLL/CED/PFT/CET/BO- CHAIN&SPROCKET/2016 | DATE :15.06.2016 |

SCHEDULE III

CONDITIONS OF CONTRACT

1. Price

The price quoted should be inclusive of Basic Price, all applicable taxes and duties including VAT, Entry tax, Octroi & other levies, P&F charges, insurance charges etc for supply of items FOR HLL site. The Supplier should pay entry taxes, as applicable and should be included in the offer.

Price quoted should be firm without any escalation till the order is completely executed.

2. Taxes/Duties/Levies

The supplier/contractor shall be entirely responsible for all taxes including entry tax, duties, license fees, etc. incurred until successful completion of contract. All central, state, municipal taxes, duties and levies payable shall be shown by the bidder separately in the Bid. The Purchaser will issue necessary 'C' Form, if required.

Note:

The term 'Machine' means the final and complete equipment/machinery as ordered and does not mean raw material, components, consumable, etc. required for the work. The Purchaser shall not be liable to pay any tax/duty/levy incurred during the transactions between the Supplier and his sub-suppliers and or Agents.

3. Insurance

The supplier shall arrange insurance coverage for transit, storage and erection.

4. Delivery/Completion Period

The sample of chain (1.3mtr) shall be supplied within two weeks from the date of receipt of Letter of Intent.

The equipment and its accessories should be delivered within **5 WEEKS** from the date of approval of the sample by HLL.

Time being the essence of the Contract, the delivery, stipulated should be strictly adhered to. Delay in delivery/non delivery of the equipment will cause loss and/or damage to Purchaser. The delivery period shall be counted from the date of sending of Purchaser's intimation of acceptance of the Supplier's offer (Letter of Intent (LOI) and/or order).

| | | |
|---|---|-----------------------------------|
|  | HLL LIFECARE LIMITED (A Government of India Enterprise) CENTRAL ENGINEERING DIVISION PEROOKADA PO, THIRUVANANTHAPURAM- 695 005, KERALA, INDIA Phn: 0471 – 2437270, 2433374 | |
| | TENDER FOR THE SUPPLY OF CONVEYOR CHAIN ASSEMBLY AND SPROCKET FOR CONVEYOR TYPE ELECTRONIC TESTING MACHINE (10 STATION ET MACHINE) | |
| PLANT: PFT | REF: IFB No.HLL/CED/PFT/CET/BO- CHAIN&SPROCKET/2016 | DATE :15.06.2016 |

5. Terms Of Payment

The payment terms offered are as follows: -

- a) 50% of the total value of equipment/s will be paid against supply and acceptance of item/equipments at site.
- b) 40% of the payment will be made after continuous 7 days of trail run at HLL site within 30 days on acceptance of the item.
- c) Balance 10% of the value of the equipment/s will be paid against a Performance Bank Guarantee (from a nationalized bank) equal to 10% of the total contract value valid for the guarantee period of one year.

Tax Deduction: All statutory deductions like Income Tax or any other government-imposed liabilities shall be borne by the Supplier/Contractor (as applicable at the time of execution of job) and shall be deducted from each bill submitted by the Supplier/Contractor.

6. Guarantee Period

The Guarantee against any possible manufacturing defects shall be given for a period of 18 months from the date of supply and acceptance of the items at HLL site or 12 months from the date of installation, whichever is earlier.

7. Liquidated damages for delays

If the equipment is not supplied to the purchaser within the time stipulated in the Order, Purchaser may at their option, either (1) recover from the Supplier/Contractor liquidated damages at the rate of 0.5 % of the total contract value for every week of delay, subject to a maximum of 7.5 % of the total contract value, or (2) at the risk and cost of the Supplier and without prejudice to the other remedies/rights as per the Contract, terminate the order wholly or partially and complete it themselves or reassign it to other Suppliers/Contractors.

8. Inspection And Testing

Purchaser shall have the right of access to the Supplier's/Contractor's works at all reasonable times to inspect and measure the progress of execution of the Order. The Supplier/Contractor should make available all tools, instruments, apparatus, equipment, facilities, services and materials to enable the Purchaser's nominee to carryout such inspection/tests without obligations. Notwithstanding such tests/inspection conducted at the Supplier's works from time to time, goods under the Order shall not be dispatched unless they have been finally inspected by the purchaser or inspection waived and dispatch specifically authorized in writing, wherever inspection during various stages of execution of the order and prior to dispatch are specifically provided for in the order, sufficient advance notice shall be given to the purchaser for the purpose, and as a

| | | |
|---|---|---------------------|
|  | HLL LIFECARE LIMITED (A Government of India Enterprise) CENTRAL ENGINEERING DIVISION PEROOKADA PO, THIRUVANANTHAPURAM- 695 005, KERALA, INDIA Phn: 0471 – 2437270, 2433374 | |
| | TENDER FOR THE SUPPLY OF CONVEYOR CHAIN ASSEMBLY AND SPROCKET FOR CONVEYOR TYPE ELECTRONIC TESTING MACHINE (10 STATION ET MACHINE) | |
| PLANT: PFT | REF: IFB No.HLL/CED/PFT/CET/BO- CHAIN&SPROCKET/2016 | DATE :15.06.2016 |

consequence of such inspection, if necessary, the Supplier shall arrange re-work at his own cost. Notwithstanding any such inspection/tests carried out at Supplier's works, the equipment shall be accepted only after receipt and successful commissioning at the site and the inspection/tests carried out at Supplier's works will not relieve his contractual obligations for conforming to the specifications under the Order.

9. Performance Guarantee

The Supplier shall fully guarantee all of the equipment supplied to perform in accordance with the specifications and to be free of all defects in design, material and workmanship. Should any equipment not performing as intended or should the design, material or workmanship prove defective within a period of 12 months from the date of successful commissioning, the equipment shall, upon notification of deficiency or defect, be promptly corrected by the Supplier to the satisfaction of Purchaser without delay and at no extra cost. If the Supplier fails to take proper corrective action to replace or repair the deficiency within a reasonable time of Purchaser's notification to this effect, the Purchaser shall be free to take such corrective action at the Supplier's risk and cost.

10. Scope of Services, Supplies and Materials:

The scope will include all services, supplies etc. for the satisfactory execution of the Contract except in so far as any of those are expressly excluded.

11. Force Majeure

- a. Neither the Supplier nor the Purchaser shall be considered in default in the performance of their obligations as per the Contract so long as such performance is prevented or delayed because of strikes, war, hostilities, revolution, civil commotion, epidemics, accidents, fire, cyclone, flood or because of any law and order proclamation, regulation or ordinance of Government or subdivision thereof or because of any act of God. The proof of existence of force majeure shall be provided by the party claiming it to the satisfaction of the other.
- b. The Supplier shall advise Purchaser initially by a Fax, followed by post, the beginning and end of any of the above causes of delay, failing which Purchaser shall not be liable to consider delays due to the above reasons. Notice as stated above should be given even in case where only the Supplier's bids are under the consideration of the Purchaser and no acceptance of the same has been given and detailed order issued.
- c. In the event of definite delay even if arising out of reasons due to force majeure, Purchaser shall have the right at their discretion to cancel the Order or part of the Order without any liability on their part to make any payment to the Supplier while reserving the right to claim refund of and any payment if advanced or paid to Supplier.

| | | |
|---|---|---------------------|
|  | HLL LIFECARE LIMITED (A Government of India Enterprise) CENTRAL ENGINEERING DIVISION PEROOKADA PO, THIRUVANANTHAPURAM- 695 005, KERALA, INDIA Phn: 0471 – 2437270, 2433374 | |
| | TENDER FOR THE SUPPLY OF CONVEYOR CHAIN ASSEMBLY AND SPROCKET FOR CONVEYOR TYPE ELECTRONIC TESTING MACHINE (10 STATION ET MACHINE) | |
| PLANT: PFT | REF: IFB No.HLL/CED/PFT/CET/BO- CHAIN&SPROCKET/2016 | DATE :15.06.2016 |

12. Assignment And Subletting

No assignment and subletting of whole or part of the order shall be permitted except with prior approval of purchase obtained in writing.

13. Correspondence

All correspondence relating to this enquiry shall be in English, to:

Deputy Chief Engineer (CED),
HLL Lifecare Limited
Central Engineering Division,
Perookada. PO, Thiruvananthapuram – 695005,
Kerala, India
Phn: 0471 – 2437270, 2433374
E-mail: rajeevrv@lifecarehll.com, krknair@lifecarehll.com

14. Indemnification Clause

The Supplier shall indemnify and hold harmless the Purchaser from and against all claims, liability, loss damage or expense, including counsel fees arising from or by reason of any actual or claimed trade mark, patent or copy right infringement or any litigation based thereon with respect to any part of the items covered by the Contract, and such obligations shall survive acceptance of payment for the items.

15. Entirety of the Agreement

All the terms agreed between the Supplier and Purchaser will be included in the Purchase/work Order/Contract. No any communication, proposal or understanding, written, oral or implied, will be considered to be included in the Purchase/work Order/Contract or form part of the Contract between the Supplier and Purchaser unless specifically agreed to in that behalf in writing between Purchaser and Supplier.

16. Settlement Of Disputes

Arbitration shall not be a means of settlement of any dispute or claim arising out of the contract relating to the work. Any disputes or difference arising between the parties with respect to the performance of any part of this agreement or any thing connected therewith, etc shall as far as possible be mutually settled by the process of dialog and negotiation.

The Courts at Thiruvananthapuram alone shall have jurisdiction in respect of settlement of any matter arising out or in connection with the contract.

| | | |
|---|---|-----------------------------------|
|  | HLL LIFECARE LIMITED (A Government of India Enterprise) CENTRAL ENGINEERING DIVISION PEROOKADA PO, THIRUVANANTHAPURAM- 695 005, KERALA, INDIA Phn: 0471 – 2437270, 2433374 | |
| | TENDER FOR THE SUPPLY OF CONVEYOR CHAIN ASSEMBLY AND SPROCKET FOR CONVEYOR TYPE ELECTRONIC TESTING MACHINE (10 STATION ET MACHINE) | |
| PLANT: PFT | REF: IFB No.HLL/CED/PFT/CET/BO- CHAIN&SPROCKET/2016 | DATE :15.06.2016 |

SCHEDULE IV

| SI. No | Item/Work Short Description | Quantity | Unit | Rate in Rs | Amount in Rs |
|---|--|--------------|--------------|------------|--------------|
| I. | SUPPLY OF SPROCKET WITH SHAFT AS PER DRAWING AND SPEIFICATIONS AT HLL,CED,PEROORKADA FACTORY, THIRUVANANTHATPURAM | | | | |
| 1. | Sprocket (Main) with shaft & key as per drawing no.HLL-D-251-00 | 1.00 | SET | | |
| 2. | Sprocket (Rear) with shaft & key as per drawing no.HLL-D-251-00 | 1.00 | SET | | |
| 3. | Spacer with bolt, nut, washer etc. as per drawing no.HLL-CED-D2-60-00 | 2.00 | NOS. | | |
| 4 | Supply of Conveyor Chain Assembly for Electronic Pinhole Testing Machine as per Drawing No. HLL-D-136-00 and tender specifications at HLL,CED, Peroorkada Factory, Thiruvananthapuram | 52.00 | MTRS. | | |
| AMOUNT IN RS (EX WORKS) | | | | | |
| EXCISE & OTHER DUTIES | | | | | |
| PACKING & FORWARDING CHARGES | | | | | |
| SALES TAX & OTHER TAXES, IF ANY | | | | | |
| ENTRY TAX, OCTROI AND OTHER LEVIES, IF ANY | | | | | |
| FREIGHT CHARGES INCLUDING TRANSIT INSURANCE | | | | | |

| | | |
|---|---|---------------------|
|  | HLL LIFECARE LIMITED (A Government of India Enterprise) CENTRAL ENGINEERING DIVISION PEROOKADA PO, THIRUVANANTHAPURAM- 695 005, KERALA, INDIA Phn: 0471 – 2437270, 2433374 | |
| | TENDER FOR THE SUPPLY OF CONVEYOR CHAIN ASSEMBLY AND SPROCKET FOR CONVEYOR TYPE ELECTRONIC TESTING MACHINE (10 STATION ET MACHINE) | |
| PLANT: PFT | REF: IFB No.HLL/CED/PFT/CET/BO- CHAIN&SPROCKET/2016 | DATE :15.06.2016 |

| | |
|---|--|
| SUPPLY PRICE F.O.R HLL SITE, PEROORKADA, TRIVANDRUM | |
| <p>(RUPEES IN WORDS)</p> <p>I hereby agree to supply/execute the item/work specified at the above quoted rate/amount.</p> <p style="text-align: right;">SUPPLIER/CONTRACTOR</p> | |

| | | |
|---|---|---------------------|
|  | HLL LIFECARE LIMITED (A Government of India Enterprise) CENTRAL ENGINEERING DIVISION PEROOKADA PO, THIRUVANANTHAPURAM- 695 005, KERALA, INDIA Phn: 0471 – 2437270, 2433374 | |
| | TENDER FOR THE SUPPLY OF CONVEYOR CHAIN ASSEMBLY AND SPROCKET FOR CONVEYOR TYPE ELECTRONIC TESTING MACHINE (10 STATION ET MACHINE) | |
| PLANT: PFT | REF: IFB No.HLL/CED/PFT/CET/BO- CHAIN&SPROCKET/2016 | DATE :15.06.2016 |

SCHEDULE V

ACCEPTANCE FORM

(To be submitted in the letter head of the firm indicating full name and address, telephone & fax numbers etc.)

From

To

Deputy Chief Engineer(CED),
HLL Lifecare Limited
Central Engineering Division,
Peroorkada. PO,
Thiruvananthapuram – 695005,
Kerala, India
Phn: 0471 – 2437270, 2433374
E-mail: rajeevrv@lifecarehll.com, krknair@lifecarehll.com

Dear Sir,

I / We, hereby offer to design/fabricate/supply/commission as detailed in schedule hereto or such portion thereof as you may specify in the acceptance of Bid at the price given in the price schedule and agree to hold this offer open till 90 days after the date of bid opening prescribed by the purchaser. I/We have understood the terms and conditions mentioned in the invitation for bid and Conditions of Contract furnished by you and have thoroughly examined the specifications in the bid document hereto and are fully aware of the nature of the scope of work required and my/our offer is to comply strictly in accordance with the requirement and the terms and conditions mentioned above.

Yours faithfully,

SIGNATURE OF THE BIDDER

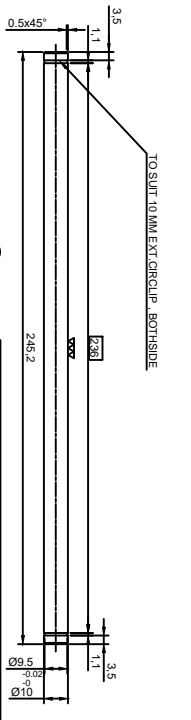
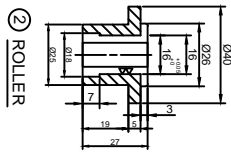
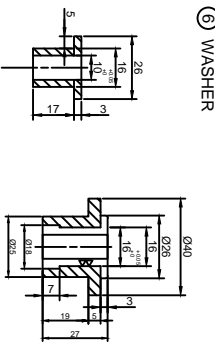
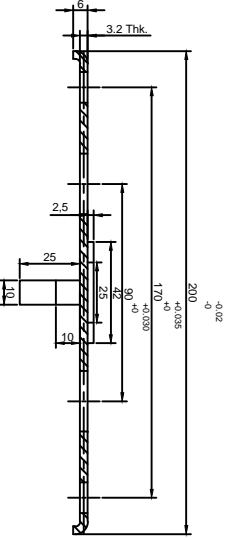
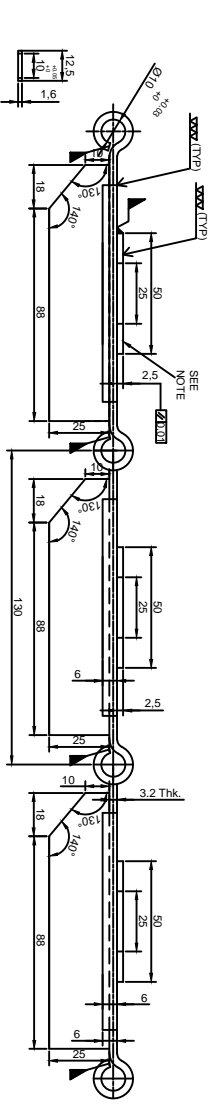
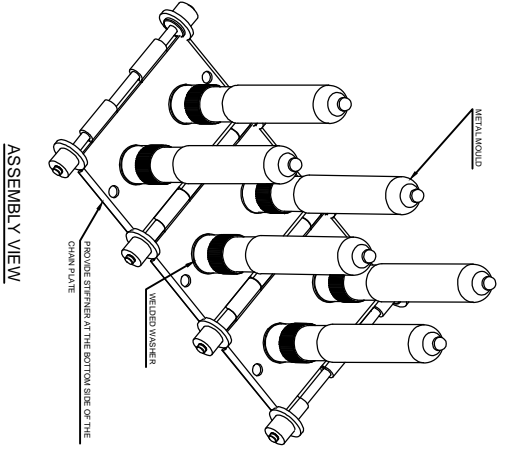
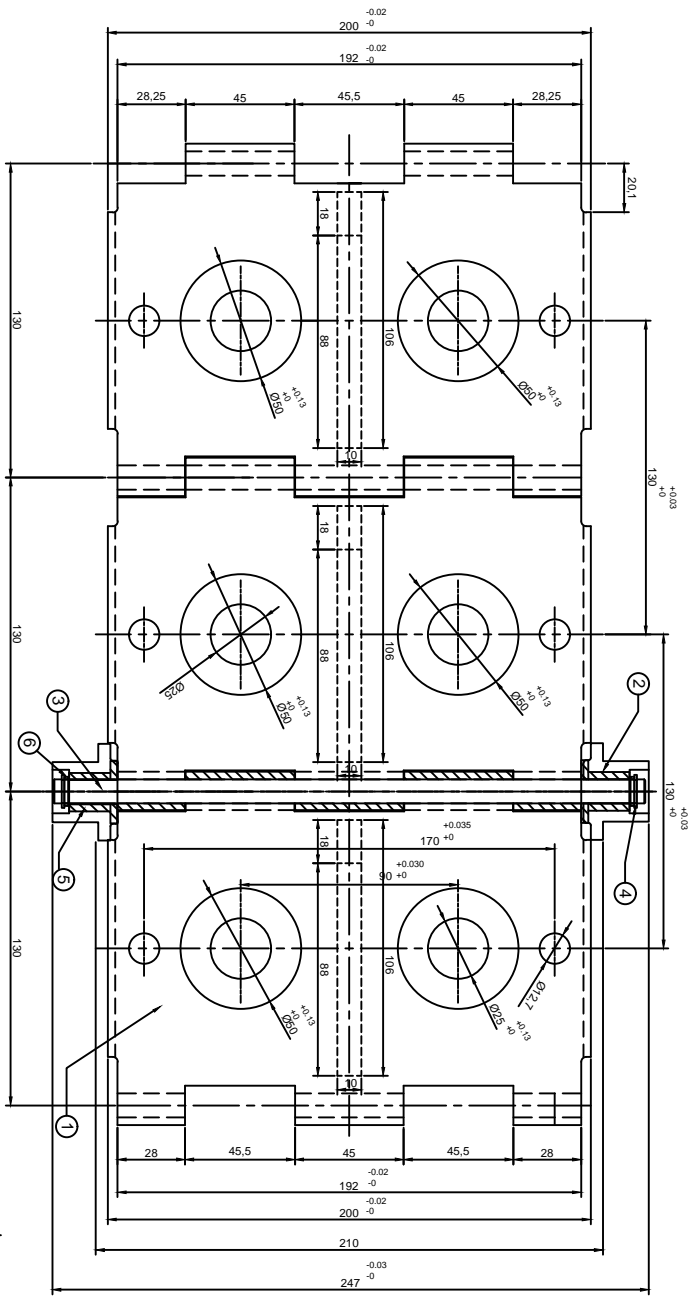

NOTE:
 1. CHAIN COMPONENTS ARE PLATED BY HARD CHROMIUM
 2. WASHER SHOULD BE SPOT WELDED TO TOP OF THE CHAIN PLATE
 3. AFTER WELDING TOP SURFACE OF WASHER MUST BE MACHINED AND KEEP THE SURFACE FINISH AND PARALLELISM.

| S.NO. | DESCRIPTION | MATERIAL | QTY | REMARKS |
|-------|-------------|------------------------------------|-----|-------------------|
| 6 | WASHER | GALVANIZED IRON | | IS-2016-1987 |
| 5 | BUSH | PB / BRONZE MIXED PIPE | | |
| 4 | EXT GIRCLIP | SPRING STEEL | | S-10 IS-3075-1985 |
| 3 | PIN | EN32 TIRRS 581 HARDENED AND GROUND | | |
| 2 | ROLLER | CS-CASTING HRC 48 | | |
| 1 | CHAIN LINK | CARBON STEEL(SI-42 SI) | | |

MATERIAL: HILL LIFECARE LTD
 Thiruvananthapuram-5
 TITLE: CONVEYOR CHAIN ASSEMBLY
 DRAWN BY: RAJKIRAN D
 CHECKED BY:
 APPROVED BY:
 DATE: 23-5-2016
 SCALE:
 ALL DIMENSIONS ARE IN MM

Drq.no:- HLL-D-136-00
 SHEET NO. 1 OF 1
 DATE: 23/05/2016

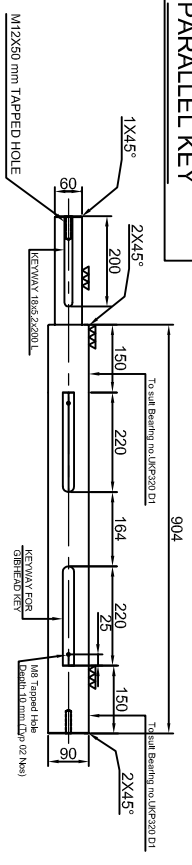
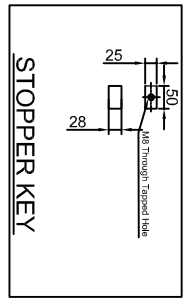
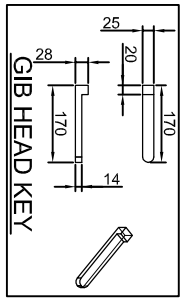
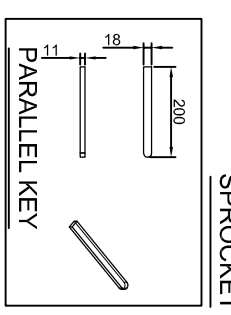
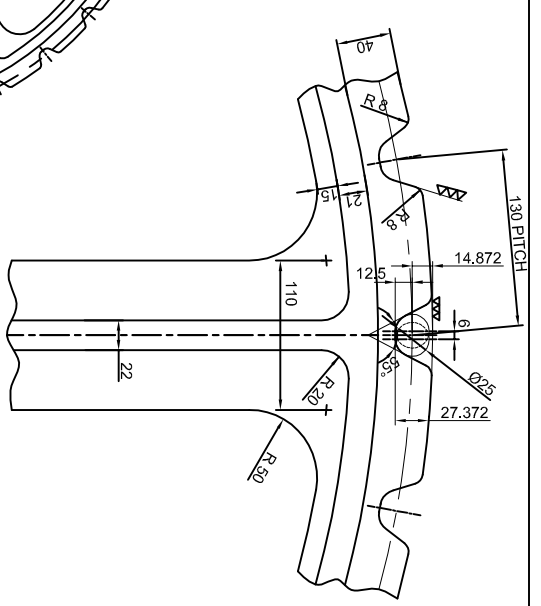
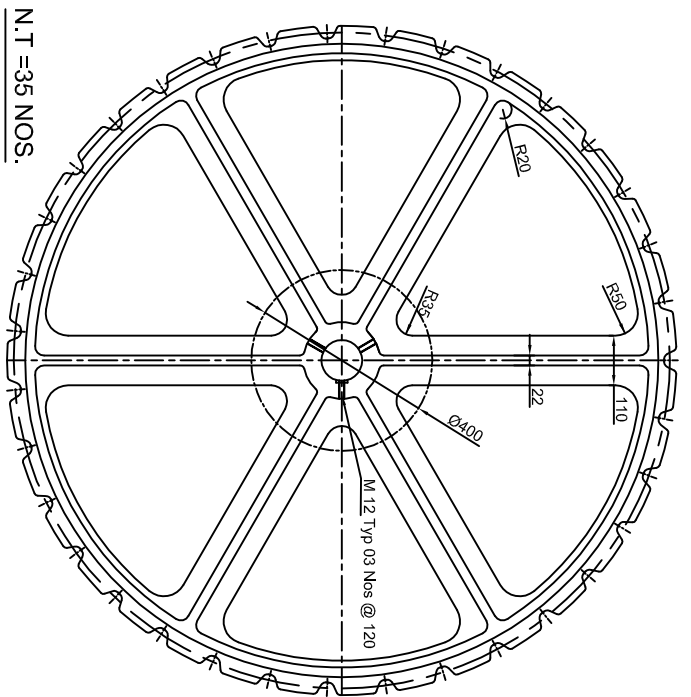
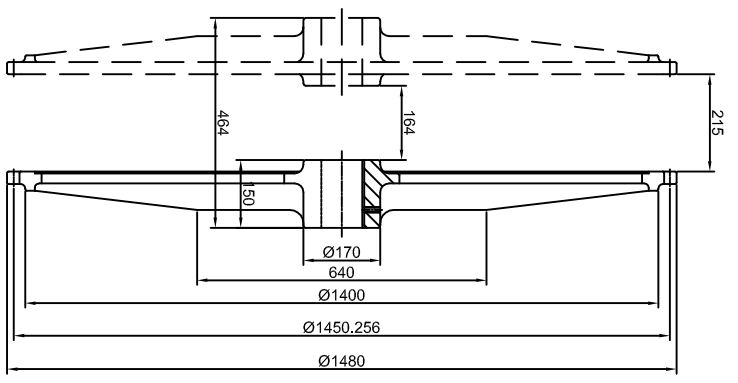
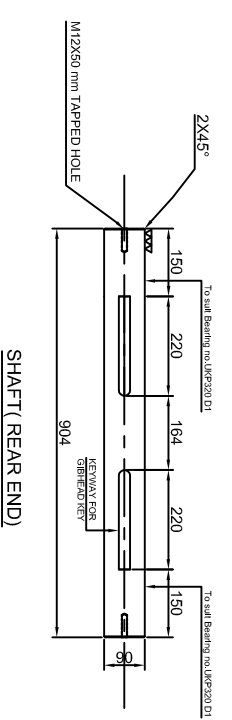
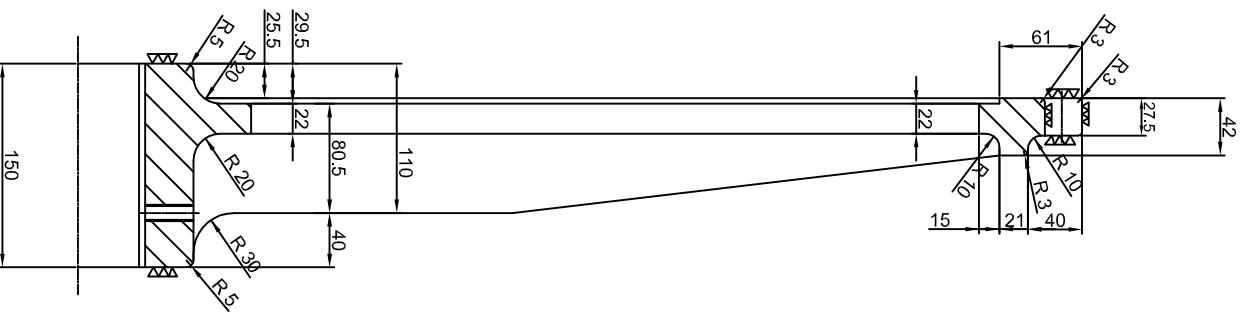

| SL. NO. | DESCRIPTION | MATERIAL | QTY. | REMARKS |
|---------|----------------|-------------------------|-------|---|
| 1 | SPROCKET | STEEL CASTING CS 125 | 4 NOS | IS:1030-1962 |
| 2 | SHAFT | EN 24 | 2 NOS | 1 no Driving side JIG 50 (As per detail) (S std) |
| 3 | GIB HEADED KEY | EN 8 | 4 NOS | 25X14X170 L Hardened and Tempered (S std : 2293-1974) |
| 4 | PARALLEL KEY | EN 8 | 1 NO | 18X14X200 L Tempered (S std:2048) |
| 5 | STOPPER KEY | EN 8 | 4 NOS | 25X28X50 L Hardened and Tempered |

MATERIAL: HLL Lifecare Limited, Thruvanchapuram-5

NO.OFF:

DRAWN BY: TITLE: DETAIL OF SPROCKET & SHAFT

CHECKED BY: (Front end and Rear end)

APPROVED BY: Drg.no:- HLL - D - 251 - 00

DATE: DATES: 02.03.2016

SCALE: SHEET NO 1 OF 1

Note:-
Teeth in both Sprockets should be in line during assembly.