

TENDER ENQUIRY DOCUMENT

FOR SUPPLY AND FIXING OF FURNITURE

FOR

**North Eastern Institute of Folk Medicine, Pasighat,
Arunachal Pradesh**

On behalf of

GOVT. OF INDIA

MINISTRY OF HEALTH & FAMILY WELFARE

HLL/PCD/NEIFM-02/14-15



BY

HLL LIFECARE LIMITED

(A Government of India Enterprise)

Procurement & Consultancy Services Division

B-14 A, Sector-62, Noida-201 307

Phone: 0120-4071500

Fax: 0120-4071513

URL: www.lifecarehll.com

Email: pcd@lifecarehll.com

INDEX

Section	Topic	Page No.
Section I	– Notice inviting Tender (NIT) -----	03
Section II	– General Instructions to Tenderers (GIT) -----	06
Section III	– Special Instructions to Tenderers (SIT) -----	24
Section IV	– General Conditions of Contract (GCC) -----	25
Section V	– Special Conditions of Contract (SCC) _____	39
Section VI	– List of Requirements -----	40
Section VII	– Technical Specifications -----	45
Section VIII	– Quality Control Requirements -----	65
Section IX	– Qualification Criteria -----	66
Section X	– Tender Form -----	70
Section XI	– Price Schedule -----	71
Section XII	– Questionnaire -----	72
Section XIII	– Bank Guarantee Form for EMD -----	73
Section XIV	– Manufacturer’s Authorisation Form -----	74
Section XV	– Bank Guarantee Form for Performance Security-----	75
Section XVI	– Contract Form -----	76
Section XVII	– Proforma of Consignee Receipt Certificate -----	78
Section XVIII	– Proforma of Final Acceptance Certificate by the Consignee -----	79
Section XIX	– -----Deleted -----	80
Section XX	– Check List for the Tenderers -----	81
Section XXI	– Consignee-----	83

SECTION I**NOTICE INVITING TENDERS (NIT)
(Domestic Tender)****Tender Enquiry No.: HLL/PCD/NEIFM-02/14-15****Dated 28.04.2014**

(1) Procurement & Consultancy Services Division of HLL Lifecare Limited, for and on behalf of North Eastern Institute of Folk Medicine (NEIFM), invites sealed tenders, from eligible and qualified tenderers for supply and fixing of Furniture items for NEIFM, Pasighat, Arunachal Pradesh:

Item Sl.no	Name of Item	Qty.	EMD
1	EXAMINATION COUCH	6	3000
2	TREATMENT COUCH	6	2400
3	FOWLER BED	50	50000
4	WHEEL CHAIR	4	1500
5	ARMLESS CHAIR	76	6100
6	BED SIDE CABINET	51	3100
7	CAFETARIA CHAIR	48	2400
8	CAFETARIA TABLE (1.2M x 1.2M)	8	3200
9	CONFERENCE CHAIR	34	6800
10	CONFERENCE TABLE 24 SEATER	1	2500
11	COT WITH MATTRESS - SINGLE	6	2900
12	DOUBLE SIDED BOOK RACK	5	2500
13	EXECUTIVE CHAIR	28	5600
14	EXECUTIVE TABLE	35	10500
15	LAB MODULAR TABLE WITH SINK	4	10000
16	LAB STOOL WITH BACK REST	50	3000
17	LECTURE HALL STUDENT CHAIR	25	2000
18	MODULAR WORK STATIONS	8	4000
19	OPEN STORAGE RACK	50	15000
20	SOFA SINGLE SEATER	10	2000
21	SOFA 3 SEATER	4	2000
22	STAFF CHAIR	57	6900
23	STORAGE CUPBOARD WITH LOCK	33	9900
24	VISITOR CHAIR	50	4500

(2) **Tender No.: HLL/PCD/NEIFM-02/14-15**

Sl. No.	Description	Schedule
i.	Dates of sale of tender enquiry documents	29.04.2014 to 28.05.2014 1000 hrs to 1600 hrs IST
ii.	Place of sale of Tender Enquiry Documents	HLL Lifecare Limited, Procurement & Consultancy Services Division, B-14 A, Sector-62, Noida-201 307
iii.	Cost of the Tender Enquiry Document	2,000/-
iv.	Pre Tender Meeting Date & Time	06.05.2014, 1100 hrs IST
v.	Pre Tender Meeting Venue	Same as 2 (ii)
vi.	Closing date & time for receipt of Tender	29.05.2014, 1400 hrs IST
vii.	Time and date of opening of Techno – Commercial tenders	29.05.2014, 1430 hrs IST
viii	Venue of Opening of Techno Commercial Tender	Same as 2 (ii)

3. Interested tenderers may obtain further information about this requirement from the above office selling the documents. Tender Enquiry Documents may be purchased on payment of non-refundable fee of Rs. 2,000/- per set in the form of account payee Demand Draft/Pay Order/Cashier's Cheque/Banker's Cheque, drawn on a scheduled bank in India, in favour of **"HLL Lifecare Limited"** payable at New Delhi.
4. If requested, the Tender Enquiry Documents will be mailed by Registered Post/Speed Post to the domestic tenderers and by international airmail to the foreign tenderers, for which extra expenditure per set will be Rs 100/- for domestic post. The tenderer is to add the applicable postage cost in the non-refundable fee mentioned in Para 3 above.
5. Tenderer may also download the tender enquiry documents from the web site www.lifecarehll.com or <http://eprocure.gov.in/cppp> and submit its tender by utilizing the downloaded document, along with the required non-refundable fee as mentioned in Para 3 above.
6. All prospective tenderers may attend the Pre Tender meeting. The venue, date and time indicated in the Para 2 above.
7. Tenderers shall ensure that their tenders, complete in all respects, are dropped in the Tender Box located at **HLL Lifecare Limited, Procurement and Consultancy Division, B-14 A, Sector-62,**

Noida-201307,Uttar Pradesh on or before the closing date and time indicated in the Para 2 above, failing which the tenders will be treated as late and rejected.

8. In the event of any of the above mentioned dates being declared as a holiday / closed day for the purchase organisation, the tenders will be sold/received/opened on the next working day at the appointed time.
9. The Tender Enquiry Documents are not transferable.

Head (P&CD)
HLL Lifecare Limited,
Procurement and Consultancy Division
B-14 A, Sector-62, Noida-201 307
Uttar Pradesh

SECTION - II**GENERAL INSTRUCTIONS TO TENDERERS (GIT)
CONTENTS**

Sl. No.	Topic	Page No.
A	PREAMBLE	
1	Definitions and Abbreviations	8
2	Introduction	9
3	Availability of Funds	10
4	Language of Tender	10
5	Eligible Tenderers	10
6	Eligible Goods and Services	10
7	Tendering Expense	10
B	TENDER ENQUIRY DOCUMENTS	
8	Contents of Tender Enquiry Documents	11
9	Amendments to Tender Enquiry Documents	11
10	Clarification of Tender Enquiry Documents	11
C	PREPARATION OF TENDERS	
11	Documents Comprising the Tender	12
12	Tender Currencies	12
13	Tender Prices	13
14	Indian Agent	15
15	Firm Price / Variable Price	15
16	Alternative Tenders	15
17	Documents Establishing Tenderer's Eligibility and Qualifications	15
18	Documents Establishing Good's Conformity to Tender Enquiry Document	15
19	Earnest Money Deposit (EMD)	16
20	Tender Validity	17
21	Signing and Sealing of Tender	17

D	SUBMISSION OF TENDERS	
22	Submission of Tenders	18
23	Late Tender	18
24	Alteration and Withdrawal of Tender	18
E	TENDER OPENING	
25	Opening of Tenders	18
F	SCRUTINY AND EVALUATION OF TENDERS	
26	Basic Principle	19
27	Preliminary Scrutiny of Tenders	19
28	Minor Infirmary/Irregularity/Non-Conformity	20
29	Discrepancy in Prices	20
30	Discrepancy between original and copies of Tender	20
31	Qualification Criteria	20
32	Conversion of Tender Currencies to Indian Rupees	21
33	Schedule-wise Evaluation	21
34	Comparison of Tenders	21
35	Additional Factors and Parameters for Evaluation and Ranking of Responsive Tenders	21
36	Tenderer's capability to perform the contract	21
37	Contacting the Purchaser	21
G	AWARD OF CONTRACT	
38	Purchaser's Right to Accept any Tender and to Reject any or All Tenders	22
39	Award Criteria	22
40	Variation of Quantities at the Time of Award	22
41	Notification of Award	22
42	Issue of Contract	22
43	Non-receipt of Performance Security and Contract by the Purchaser/Consignee	23
44	Return of EMD	23
45	Publication of Tender Result	23
46	Corrupt or Fraudulent Practices	23

GENERAL INSTRUCTIONS TO TENDERERS (GIT)

A. PREAMBLE

1. Definitions and Abbreviations

1.1 The following definitions and abbreviations, which have been used in these documents shall have the meanings as indicated below:

1.2. Definitions:

- (i) "Purchaser" means the organization purchasing goods and services as incorporated in the Tender Enquiry document.
- (ii) "Tender" means Bids / Quotation / Tender received from a Firm / Tenderer / Bidder.
- (iii) "Tenderer" means Bidder/ the Individual or Firm submitting Bids / Quotation / Tender
- (iii) "Supplier" means the individual or the firm supplying the goods and services as incorporated in the contract.
- (iv) "Goods" means the articles, material, commodities, livestock, furniture, fixtures, raw material, spares, instruments, machinery, equipment, medical equipment, industrial plant etc. which the supplier is required to supply to the purchaser under the contract.
- (v) "Services" means services allied and incidental to the supply of goods, such as transportation, installation, commissioning, provision of technical assistance, training, after sales service, maintenance service and other such obligations of the supplier covered under the contract.
- (vi) "Earnest Money Deposit" (EMD) means Bid Security/ monetary or financial guarantee to be furnished by a tenderer along with its tender.
- (vii) "Contract" means the written agreement entered into between the purchaser and/or consignee and the supplier, together with all the documents mentioned therein and including all attachments, annexure etc. therein.
- (viii) "Performance Security" means monetary or financial guarantee to be furnished by the successful tenderer for due performance of the contract placed on it. Performance Security is also known as Security Deposit.
- (ix) "Consignee" means the Hospital/Institute/Medical College/ person to whom the goods are required to be delivered as specified in the Contract. If the goods are required to be delivered to a person as an interim consignee for the purpose of despatch to another person as provided in the Contract then that "another" person is the consignee, also known as ultimate consignee.
- (x) "Specification" means the document/standard that prescribes the requirement with which goods or service has to conform.
- (xi) "Inspection" means activities such as measuring, examining, testing, gauging one or more characteristics of the product or service and comparing the same with the specified requirement to determine conformity.
- (xii) "Day" means calendar day.

1.3 Abbreviations:

- (i) "TE Document" means Tender Enquiry Document
- (ii) "NIT" means Notice Inviting Tenders.
- (iii) "GIT" means General Instructions to Tenderers
- (iv) "SIT" means Special Instructions to Tenderers
- (v) "GCC" means General Conditions of Contract
- (vi) "SCC" means Special Conditions of Contract
- (vii) "DGS&D" means Directorate General of Supplies and Disposals
- (viii) "NSIC" means National Small Industries Corporation
- (ix) "PSU" means Public Sector Undertaking
- (x) "CPSU" means Central Public Sector Undertaking
- (xi) "LSI" means Large Scale Industry
- (xii) "SSI" means Small Scale Industry
- (xiii) "LC" means Letter of Credit
- (xiv) "DP" means Delivery Period
- (xv) "BG" means Bank Guarantee
- (xvi) "ED" means Excise Duty
- (xvii) "CD" means Custom Duty
- (xviii) "VAT" means Value Added Tax
- (xix) "CENVAT" means Central Value Added Tax
- (xx) "CST" means Central Sales Tax
- (xxi) "RR" means Railway Receipt
- (xxii) "BL" means Bill of Lading
- (xxiii) "FOB" means Free on Board
- (xxiv) "FCA" means Free Carrier
- (xxv) "FOR" means Free On Rail
- (xxvi) "CIF" means Cost, Insurance and Freight
- (xxvii) "CIP (Destinations)" means Carriage and Insurance Paid up to named port of destination. Additionally the Insurance (local transportation and storage) would be extended and borne by the Supplier from ware house to the consignee site for a period including 3 months beyond date of delivery.
- (xxviii) "DDP" means Delivery Duty Paid named place of destination (consignee site)
- (xxix) "INCOTERMS" means International Commercial Terms as on the date of Tender Opening
- (xxx) "MOH&FW" means Ministry of Health & Family Welfare, Government of India
- (xxxi) "Dte. GHS" means Directorate General and Health Services, MOH&FW.
- (xxxii) "CMC" means Comprehensive maintenance Contract (labour, spare and preventive maintenance)
- (xxxiii) "RT" means Re-Tender.

2. Introduction

- 2.1 The Purchaser has issued these TE documents for purchase of goods and related services as mentioned in Section – VI – "List of Requirements", which also indicates, *interalia*, the required delivery schedule, terms and place of delivery.
- 2.2 This section (Section II - "General Instruction Tenderers") provides the relevant information as well as instructions to assist the prospective tenderers in preparation and submission of tenders. It also includes the mode and procedure to be adopted by the purchaser for receipt

and opening as well as scrutiny and evaluation of tenders and subsequent placement of contract.

2.3 The tenderers shall also read the Special Instructions to Tenderers (SIT) related to this purchase, as contained in Section III of these documents and follow the same accordingly. Whenever there is a conflict between the GIT and the SIT, the provisions contained in the SIT shall prevail over those in the GIT.

2.4 Before formulating the tender and submitting the same to the purchaser, the tenderer should read and examine all the terms, conditions, instructions, checklist etc. contained in the TE documents. Failure to provide and/or comply with the required information, instructions etc. incorporated in these TE documents may result in rejection of its tender.

3. Availability of Funds

3.1 Expenditure to be incurred for the proposed purchase will be met from the funds available with the purchaser/consignee.

4. Language of Tender

4.1 The tender submitted by the tenderer and all subsequent correspondence and documents relating to the tender exchanged between the tenderer and the purchaser, shall be written in the English language, unless otherwise specified in the Tender Enquiry. However, the language of any printed literature furnished by the tenderer in connection with its tender may be written in any other language provided the same is accompanied by an English translation and, for purposes of interpretation of the tender, the English translation shall prevail.

4.2 The tender submitted by the tenderer and all subsequent correspondence and documents relating to the tender exchanged between the tenderer and the purchaser, may also be written in the Hindi language, provided that the same are accompanied by English translation, in which case, for purpose of interpretation of the tender etc, the English translations shall prevail.

5. Eligible Tenderers

5.1 This invitation for tenders is open to all suppliers who fulfil the eligibility criteria specified in these documents.

6. Eligible Goods and Services

6.1 All goods and related services to be supplied under the contract shall have their origin in India or any other country with which India has not banned trade relations. The term “origin” used in this clause means the place where the goods are mined, grown, produced, or manufactured or from where the related services are arranged and supplied.

7. Tendering Expense

7.1 The tenderer shall bear all costs and expenditure incurred and/or to be incurred by it in connection with its tender including preparation, mailing and submission of its tender and for subsequent processing the same. The purchaser will, in no case be responsible or liable for any such cost, expenditure etc regardless of the conduct or outcome of the tendering process.

B. TENDER ENQUIRY DOCUMENTS

8. Content of Tender Enquiry Documents

8.1 In addition to Section I – “Notice inviting Tender” (NIT), the TE documents include:

- Section II – General Instructions to Tenderers (GIT)
- Section III – Special Instructions to Tenderers (SIT)
- Section IV – General Conditions of Contract (GCC)
- Section V – Special Conditions of Contract (SCC)
- Section VI – List of Requirements
- Section VII – Technical Specifications
- Section VIII – Quality Control Requirements
- Section IX – Qualification Criteria
- Section X – Tender Form
- Section XI – Price Schedules
- Section XII – Questionnaire
- Section XIII – Bank Guarantee Form for EMD
- Section XIV – Manufacturer’s Authorisation Form
- Section XV – Bank Guarantee Form for Performance Security/CMC Security
- Section XVI – Contract Forms A & B
- Section XVII – Proforma of Consignee Receipt Certificate
- Section XVIII – Proforma of Final Acceptance Certificate by the consignee
- Section XIX – Deleted
- Section XX – Check List for the Tenderers
- Section XXI – Consignee List

8.2 The relevant details of the required goods and services, the terms, conditions and procedure for tendering, tender evaluation, placement of contract, the applicable contract terms and, also, the standard formats to be used for this purpose are incorporated in the above-mentioned documents. The interested tenderers are expected to examine all such details etc to proceed further.

9. Amendments to TE documents

9.1 At any time prior to the deadline for submission of tenders, the purchaser may, for any reason deemed fit by it, modify the TE documents by issuing suitable amendment(s) to it.

9.2 Such an amendment will be notified in writing by registered/speed post or by fax/telex/e-mail, followed by copy of the same by registered post to all prospective tenderers, which have received the TE documents and will be binding on them.

9.3 In order to provide reasonable time to the prospective tenderers to take necessary action in preparing their tenders as per the amendment, the purchaser may, at its discretion extend the deadline for the submission of tenders and other allied time frames, which are linked with that deadline.

10. Clarification of TE documents

10.1 A tenderer requiring any clarification or elucidation on any issue of the TE documents may take up the same with the purchaser in writing. The purchaser will respond in writing to such request provided the same is received by the purchaser not later than fifteen days (unless otherwise specified in the SIT) prior to the prescribed date of submission of tender.

C. PREPARATION OF TENDERS

11. Documents Comprising the Tender

11.1 The **Two Tender System**, i.e. “Techno – Commercial Tender” and “Price Tender” prepared by the tenderer shall comprise the following:

A) **Techno – Commercial Tender (Un priced Tender)**

- i) Earnest money furnished in accordance with GIT clause 19.1 alternatively, documentary evidence as per GIT clause 19.2 for claiming exemption from payment of earnest money.
- ii) Tender Form as per Section X (without indicating any prices).
- iii) Documentary evidence, as necessary in terms of clauses 5 and 17 establishing that the tenderer is eligible to submit the tender and, also, qualified to perform the contract if its tender is accepted.
- iv) Tenderer/Agent who quotes for goods manufactured by other manufacturer shall furnish Manufacturer’s Authorisation Form.
- v) Power of Attorney in favour of signatory of TE documents and signatory of Manufacturer’s Authorisation Form.
- vi) Documents and relevant details to establish in accordance with GIT clause 18 that the goods and the allied services to be supplied by the tenderer conform to the requirement of the TE documents.
- vii) Performance Statement as per section IX along with relevant copies of orders and end users’ satisfaction certificate.
- viii) Price Schedule(s) as per Section XI filled up with all the details including Make, Model etc. of the goods offered with prices blank (without indicating any prices).
- ix) Deleted.
- x) Checklist as per Section XX.

B) **Price Tender:**

The information given at clause no. 11.1 A) (viii) above should be reproduced with the prices indicated.

N.B.

1. All pages of the Tender should be page numbered and indexed.
2. It is the responsibility of tenderer to go through the TE document to ensure furnishing all required documents in addition to above, if any.

11.2 The authorized signatory of the tenderer must sign the tender duly stamped at appropriate places and initial all the remaining pages of the tender.

11.3 A tender, which does not fulfil any of the above requirements and/or gives evasive information/reply against any such requirement, shall be liable to be ignored and rejected.

11.4 Tender sent by fax/telex/cable/electronically shall be ignored.

12. Tender currencies

12.1 The tenderer supplying indigenous goods or already imported goods shall quote only in Indian Rupees.

12.2 Deleted.

12.3 Tenders, where prices are quoted in any other way shall be treated as non -responsive and rejected.

13 Tender Prices

- 13.1 The Tenderer shall indicate on the Price Schedule provided under Section XI all the specified components of prices shown therein including the unit prices and total tender prices of the goods and services it proposes to supply against the requirement. All the columns shown in the price schedule should be filled up as required. If any column does not apply to a tenderer, same should be clarified as “NA” by the tenderer.
- 13.2 If there is more than one schedule in the List of Requirements, the tenderer has the option to submit its quotation for any one or more schedules and, also, to offer special discount for combined schedules. However, while quoting for a schedule, the tenderer shall quote for the complete requirement of goods and services as specified in that particular schedule.
- 13.3 The quoted prices for goods offered from within India and that for goods offered from abroad are to be indicated separately in the applicable Price Schedules attached under Section XI.
- 13.4 While filling up the columns of the Price Schedule, the following aspects should be noted for compliance:
- 13.4.1 For domestic goods or goods of foreign origin located within India, the prices in the corresponding price schedule shall be entered separately in the following manner:
- a) the price of the goods, quoted ex-factory/ ex-showroom/ ex-warehouse/ off-the-shelf, as applicable, including all taxes and duties like sales tax, CST VAT, CENVAT, Custom Duty, Excise Duty etc. already paid or payable on the components and raw material used in the manufacture or assembly of the goods quoted ex-factory etc. or on the previously imported goods of foreign origin quoted ex-showroom etc;
 - b) any sales or other taxes and any duties including excise duty, which will be payable on the goods in India if the contract is awarded;
 - c) charges towards Packing & Forwarding, Inland Transportation, Insurance (local transportation and storage) would be borne by the Supplier from ware house to the consignee site for a period including 3 months beyond date of delivery, Loading/Unloading and other local costs incidental to delivery of the goods to their final destination as specified in the List of Requirements and Price Schedule;
 - d) the price of Incidental Services, as mentioned in List of Requirements and Price Schedule;
 - e) Deleted;
 - f) Deleted.
 - g) Deleted.
- 13.4.2 Deleted
- 13.5 Additional information and instruction on Duties and Taxes:
- 13.5.1 If the Tenderer desires to ask for excise duty, sales tax/ VAT, Service Tax, Works Contract Tax etc. to be paid extra, the same must be specifically stated. In the absence of any such stipulation the price will be taken inclusive of such duties and taxes and no claim for the same will be entertained later.
- 13.5.2 Excise Duty:
- a) If reimbursement of excise duty is intended as extra over the quoted prices, the supplier must specifically say so also indicating the rate, quantum and nature of the duty applicable. In the absence of any such stipulation it will be presumed that the prices quoted are firm and final and no claim on account of excise duty will be entertained after the opening of tenders.
 - b) If a Tenderer chooses to quote a price inclusive of excise duty and also desires to be reimbursed for variation, if any, in the excise duty during the time of supply, the tenderer

must clearly mention the same and also indicate the rate and quantum of excise duty included in its price. Failure to indicate all such details in clear terms may result in rejection of that tender.

- c) Subject to sub clauses 13.5.2 (a) & (b) above, any change in excise duty upward/downward as a result of any statutory variation in excise duty taking place within contract terms shall be allowed to the extent of actual quantum of excise duty paid by the supplier. In case of downward revision in excise duty, the actual quantum of reduction of excise duty shall be reimbursed to the purchaser by the supplier. All such adjustments shall include all reliefs, exemptions, rebates, concession etc. if any obtained by the supplier.

13.5.3 Sales Tax:

If a tenderer asks for sales tax/ VAT, Service Tax and Works Contract Tax to be paid extra, the rate and nature of sales tax applicable should be shown separately. The sales tax / VAT, Service Tax and Works Contract Tax will be paid as per the rate at which it is liable to be assessed or has actually been assessed provided the transaction of sale is legally liable to sales tax / VAT, Service Tax and Works Contract Tax and is payable as per the terms of the contract. If any refund of Tax is received at a later date, the Supplier must return the amount forth-with to the purchaser.

13.5.4 Octroi Duty and Local Duties & Taxes:

Normally, goods to be supplied to government departments against government contracts are exempted from levy of town duty, Octroi duty, terminal tax and other levies of local bodies. However, on some occasions, the local bodies (like town body, municipal body etc.) as per their regulations allow such exemptions only on production of certificate to this effect from the concerned government department. Keeping this in view, the supplier shall ensure that the stores to be supplied by the supplier against the contract placed by the purchaser are exempted from levy of any such duty or tax and, wherever necessary, obtain the exemption certificate from the purchaser.

However, if a local body still insists upon payment of such local duties and taxes, the same should be paid by the supplier to the local body to avoid delay in supplies and possible demurrage charges and obtain a receipt for the same. The supplier should forward the receipt obtained for such payment to the purchaser to enable the purchaser reimburse the supplier and take other necessary action in the matter.

13.5.5 Deleted

13.6 Deleted.

- 13.7 For insurance of goods to be supplied, relevant instructions as provided under GCC Clause 11 shall be followed.

13.8 Deleted

- 13.9 The need for indication of all such price components by the tenderers, as required in this clause (viz., GIT clause 13) is for the purpose of comparison of the tenders by the purchaser and will no way restrict the purchaser's right to award the contract on the selected tenderer on any of the terms offered.

- 13.10 All sundry equipments, fittings, units assemblies, accessories, hardware items, foundation bolts, termination lugs for electrical connections, and all other items which are useful and necessary for efficient assembly and installation of equipment and components of the work shall be deemed to have been included in the tender irrespectively of the fact whether such items are specifically mentioned in the tender documents or not.
- 13.11 Tenderers are required to quote as per the specification of the stores. The deviation to specification if any must be brought out clearly giving a deviation statement. Detailed break up of prices for the main equipment and the accessory /optional item must be provided separately, item wise in the same serial order as listed in the technical bid.
- 13.12 Deleted.

14. Deleted

15. Firm Price

- 15.1 Unless otherwise specified in the SIT, prices quoted by the tenderer shall remain firm and fixed during the currency of the contract and not subject to variation on any account.
- 15.2 However, as regards taxes and duties, if any, chargeable on the goods and payable, the conditions stipulated in GIT clause 13 will apply.

16. Alternative Tenders

- 16.1 Alternative Tenders are not permitted.
- 16.2 However the Tenderers can quote alternate models meeting the tender specifications of same manufacturer with single EMD.

17 Documents Establishing Tenderer's Eligibility and Qualifications

- 17.1 Pursuant to GIT clause 11, the tenderer shall furnish, as part of its tender, relevant details and documents establishing its eligibility to quote and its qualifications to perform the contract if its tender is accepted.
- 17.2 The documentary evidence needed to establish the tenderer's qualifications shall fulfil the following requirements:
- a) in case the tenderer offers to supply goods, which are manufactured by some other firm, the tenderer has been duly authorised by the goods manufacturer to quote for and supply the goods to the purchaser. The tenderer shall submit the manufacturer's authorization letter to this effect as per the standard form provided under Section XIV in this document.
 - b) the tenderer has the required financial, technical and production capability necessary to perform the contract and, further, it meets the qualification criteria incorporated in the Section IX in these documents.
 - c) Deleted.
 - d) Deleted.

18. Documents establishing Good's Conformity to TE document.

- 18.1 The tenderer shall provide in its tender the required as well as the relevant documents like technical data, literature, drawings etc. to establish that the goods and services offered in the tender fully conform to the goods and services specified by the purchaser in the TE documents. For this purpose the tenderer shall also provide a clause-by-clause commentary on the technical specifications and other technical details incorporated by the purchaser in

the TE documents to establish technical responsiveness of the goods and services offered in its tender.

- 18.2 In case there is any variation and/or deviation between the goods & services prescribed by the purchaser and that offered by the tenderer, the tenderer shall list out the same in a chart form without ambiguity and provide the same along with its tender.
- 18.3 If a tenderer furnishes wrong and/or misguiding data, statement(s) etc. about technical acceptability of the goods and services offered by it, its tender will be liable to be ignored and rejected in addition to other remedies available to the purchaser in this regard.

19. Earnest Money Deposit (EMD)

- 19.1 Pursuant to GIT clauses 8.1 and 11.1(d) the tenderer shall furnish along with its tender, earnest money for amount as mentioned in column (d) of Table-1 attached with Qualification Criteria (Section – IX). The earnest money is required to protect the purchaser against the risk of the tenderer's unwarranted conduct as amplified under sub-clause 19.7 below.
- 19.2 The tenderers who are currently registered and, also, will continue to remain registered during the tender validity period with Directorate General of Supplies & Disposals or with National Small Industries Corporation for the specific goods as per tender enquiry specification shall be eligible for exemption from EMD. Vague stipulations in the Registration Certificate such as "to customers' specification" etc. will not be acceptable for exemption from furnishing of earnest money. In case the tenderer falls in these categories, it should furnish copy of its valid registration details (with DGS&D or NSIC, as the case may be).
- 19.3 The earnest money shall be denominated in Indian Rupees or equivalent currencies as per GIT clause 12.2. The earnest money shall be furnished in one of the following forms:
- i) Account Payee Demand Draft
 - ii) Banker's cheque and
 - iii) Bank Guarantee
- 19.4 The demand draft or banker's cheque shall be drawn on any commercial bank in India or country of the tenderer, in favour of the "**HLL Lifecare Limited**" payable at New Delhi. In case of bank guarantee, the same is to be provided from any commercial bank in India or country of the tenderer as per the format specified under Section XIII in these documents.
- 19.5 The earnest money shall be valid for a period of forty-five (45) days beyond the validity period of the tender. As validity period of Tender as per Clause 20 of GIT is 120 days, the EMD shall be valid for 165 days from Techno – Commercial Tender opening date.
- 19.6 Unsuccessful tenderers' earnest money along with un-opened price bid will be returned to them without any interest, after expiry of the tender validity period, but not later than thirty days after conclusion of the resultant contract. Successful tenderer's earnest money will be returned without any interest, after receipt of performance security from that tenderer.
- 19.7 Earnest Money is required to protect the purchaser against the risk of the Tenderer's conduct, which would warrant the forfeiture of the EMD. Earnest money of a tenderer will be forfeited, if the tenderer withdraws or amends its tender or impairs or derogates from the tender in any respect within the period of validity of its tender or if it comes to notice that the information/documents furnished in its tender is incorrect, false, misleading or forged without prejudice to other rights of the purchaser. The successful tenderer's earnest money will be forfeited without prejudice to other rights of Purchaser if it fails to furnish the required performance security within the specified period.
- 19.8 Deleted.

20. Tender Validity

- 20.1 If not mentioned otherwise in the SIT, the tenders shall remain valid for acceptance for a period of 120 days (One hundred and twenty days) after the date of tender opening prescribed in the TE document. Any tender valid for a shorter period shall be treated as unresponsive and rejected.
- 20.2 In exceptional cases, the tenderers may be requested by the purchaser to extend the validity of their tenders up to a specified period. Such request(s) and responses thereto shall be conveyed by surface mail or by fax/ telex/cable followed by surface mail. The tenderers, who agree to extend the tender validity, are to extend the same without any change or modification of their original tender and they are also to extend the validity period of the EMD accordingly. A tenderer, however, may not agree to extend its tender validity without forfeiting its EMD.
- 20.3 In case the day up to which the tenders are to remain valid falls on/ subsequently declared a holiday or closed day for the purchaser, the tender validity shall automatically be extended up to the next working day.

21. Signing and Sealing of Tender

- 21.1 The tenderers shall submit their tenders as per the instructions contained in GIT Clause 11.
- 21.2 Unless otherwise mentioned in the SIT, a tenderer shall submit two copies of its tender marking them as "Original" and "Duplicate". Duplicate tenders may contain all pages including Technical Literature/Catalogues as per in Original tenders..
- 21.3 The original and duplicate tender shall either be typed or written in indelible ink and the same shall be signed by the tenderer or by a person(s) who has been duly authorized to bind the tenderer to the contract. The letter of authorization shall be by a written power of attorney, which shall also be furnished along with the tender.
- 21.4 Both the copies of the tender shall be duly signed at the appropriate places as indicated in the TE documents and all other pages of the tender including printed literature, if any shall be initialled by the same person(s) signing the tender. The tender shall not contain any erasure or overwriting, except as necessary to correct any error made by the tenderer and, if there is any such correction; the same shall be initialled by the person(s) signing the tender.
- 21.5 The tenderer is to seal the original and duplicate copy of the tender in separate envelopes, duly marking the same as "Original" and "Duplicate" and so on and writing the address of the purchaser and the tender reference number on the envelopes. The sentence "NOT TO BE OPENED" before _____ (The tenderer is to put the date & time of tender opening) are to be written on these envelopes. The inner envelopes are then to be put in a bigger outer envelope, which will also be duly sealed, marked etc. as above. If the outer envelope is not sealed and marked properly as above, the purchaser will not assume any responsibility for its misplacement, premature opening, late opening etc.
- 21.6 TE document seeks quotation following **two Tender System**, in two parts. First part will be known as '**Techno - Commercial Tender**', and the second part '**Price Tender**' as specified in clause 11 of GIT. Tenderer shall seal '**Techno - Commercial Tender**' and '**Price Tender**' separately and covers will be suitably super scribed. Both these sealed covers shall be put in a bigger cover and sealed and procedure prescribed in Paras 21.1 to 21.5 followed.

D. SUBMISSION OF TENDERS

22. Submission of Tenders

- 22.1 Unless otherwise specified, the tenderers are to deposit the tenders in the tender box kept for this purpose at **HLL Lifecare Limited, Procurement and Consultancy Division, B-14 A, Sector-62, Noida-201 307, Uttar Pradesh**. In case of bulky tender, which can not be put into tender box, the same shall be submitted by the tenderer by hand to **Head (P&CD)** or his nominee, **HLL Lifecare Limited, Procurement and Consultancy Division, B-14 A, Sector-62, Noida-201 307, Uttar Pradesh**. The officer receiving the tender will give the tenderer an official receipt duly signed with date and time.
- 22.2 The tenderers must ensure that they deposit their tenders not later than the closing time and date specified for submission of tenders. It is the responsibility of the tenderer to ensure that their Tenders whether sent by post or by courier or by person, are dropped in the Tender Box by the specified clearing date and time. In the event of the specified date for submission of tender falls on / is subsequently declared a holiday or closed day for the purchaser, the tenders will be received up to the appointed time on the next working day.

23. Late Tender

- 23.1 A tender, which is received after the specified date and time for receipt of tenders will be treated as "late" tender and will be ignored.

24. Alteration and Withdrawal of Tender

- 24.1 The tenderer, after submitting its tender, is permitted to alter / modify its tender so long as such alterations / modifications are received duly signed, sealed and marked like the original tender, within the deadline for submission of tenders. Alterations / modifications to tenders received after the prescribed deadline will not be considered.
- 24.2 No tender should be withdrawn after the deadline for submission of tender and before expiry of the tender validity period. If a tenderer withdraws the tender during this period, it will result in forfeiture of the earnest money furnished by the tenderer in its tender.

E. TENDER OPENING

25. Opening of Tenders

- 25.1 The purchaser will open the tenders at the specified date and time and at the specified place as indicated in the NIT.

In case the specified date of tender opening falls on / is subsequently declared a holiday or closed day for the purchaser, the tenders will be opened at the appointed time and place on the next working day.

- 25.2 Authorized representatives of the tenderers, who have submitted tenders on time may attend the tender opening provided they bring with them letters of authority from the corresponding tenderers.

The tender opening official(s) will prepare a list of the representatives attending the tender opening. The list will contain the representatives' names & signatures and corresponding tenderers' names and addresses.

- 25.3 Two - Tender system as mentioned in Para 21.6 above will be as follows. The **Techno - Commercial Tenders** are to be opened in the first instance, at the prescribed time and date as indicated in NIT. These Tenders shall be scrutinized and evaluated by the competent committee/ authority with reference to parameters prescribed in the TE document. During the Techno - Commercial Tender opening, the tender opening official(s) will read the salient features of the tenders like brief description of the goods offered, delivery period, Earnest Money Deposit and any other special features of the tenders, as deemed fit by the tender opening official(s). Thereafter, in the second stage, the Price Tenders of only the Techno - Commercially acceptable offers (as decided in the first stage) shall be opened for further scrutiny and evaluation on a date notified after the evaluation of the Techno – Commercial tender. The prices, special discount if any of the goods offered etc., as deemed fit by tender opening official(s) will be read out.

F. SCRUTINY AND EVALUATION OF TENDERS

26. Basic Principle

- 26.1 Tenders will be evaluated on the basis of the terms & conditions already incorporated in the TE document, based on which tenders have been received and the terms, conditions etc. mentioned by the tenderers in their tenders. No new condition will be brought in while scrutinizing and evaluating the tenders.

27. Preliminary Scrutiny of Tenders

- 27.1 The Purchaser will examine the Tenders to determine whether they are complete, whether any computational errors have been made, whether required sureties have been furnished, whether the documents have been properly signed stamped and whether the Tenders are generally in order.
- 27.2 Prior to the detailed evaluation of Price Tenders, pursuant to GIT Clause 34, the Purchaser will determine the substantial responsiveness of each Tender to the TE Document. For purposes of these clauses, a substantially responsive Tender is one, which conforms to all the terms and conditions of the TE Documents without material deviations. Deviations from, or objections or reservations to critical provisions such as those concerning Performance Security (GCC Clause 5), Warranty (GCC Clause 15), EMD (GIT Clause 19), Taxes & Duties (GCC Clause 20), Force Majeure (GCC Clause 26) and Applicable law (GCC Clause 31) will be deemed to be a material deviation. The Purchaser's determination of a Tender's responsiveness is to be based on the contents of the tender itself without recourse to extrinsic evidence.
- 27.3 If a Tender is not substantially responsive, it will be rejected by the Purchaser and cannot subsequently be made responsive by the Tenderer by correction of the nonconformity.
- 27.4 The tenders will be scrutinized to determine whether they are complete and meet the essential and important requirements, conditions etc. as prescribed in the TE document. The tenders, which do not meet the basic requirements, are liable to be treated as non – responsive and will be summarily ignored.
- 27.5 The following are some of the important aspects, for which a tender shall be declared non – responsive and will be summarily ignored;
- (i) Tender form as per Section X (signed and stamped) not enclosed
 - (ii) Tender is unsigned.
 - (iii) Tender validity is shorter than the required period.
 - (iv) Required EMD (Amount, validity etc.)/exemption documents have not been provided.

- (v) Tenderer has quoted for goods manufactured by other manufacturer(s) without the required Manufacturer's Authorisation Form as per Section XIV.
- (vi) Tenderer has not agreed to give the required performance security.
- (vii) Goods offered are not meeting the tender enquiry specification.
- (viii) Tenderer has not agreed to other essential condition(s) specially incorporated in the tender enquiry like terms of payment, liquidated damages clause, warranty clause, dispute resolution mechanism applicable law.
- (ix) Poor/ unsatisfactory past performance.
- (x) Tenderers who stand deregistered/banned/blacklisted by any Govt. Authorities.
- (xi) Tenderer is not eligible as per GIT Clauses 5.1 & 17.1.
- (xii) Tenderer has not quoted for the entire quantity in a schedule as specified in the List of Requirements.

28. Minor Infirmary/Irregularity/Non-Conformity

- 28.1 If during the preliminary examination, the purchaser find any minor informality and/or irregularity and/or non-conformity in a tender, the purchaser may waive the same provided it does not constitute any material deviation and financial impact and, also, does not prejudice or affect the ranking order of the tenderers. Wherever necessary, the purchaser will convey its observation on such 'minor' issues to the tenderer by registered/speed post etc. asking the tenderer to respond by a specified date. If the tenderer does not reply by the specified date or gives evasive reply without clarifying the point at issue in clear terms, that tender will be liable to be ignored.

29 Discrepancies in Prices

- 29.1 If, in the price structure quoted by a tenderer, there is discrepancy between the unit price and the total price (which is obtained by multiplying the unit price by the quantity), the unit price shall prevail and the total price corrected accordingly, unless the purchaser feels that the tenderer has made a mistake in placing the decimal point in the unit price, in which case the total price as quoted shall prevail over the unit price and the unit price corrected accordingly.
- 29.2 If there is an error in a total price, which has been worked out through addition and/or subtraction of subtotals, the subtotals shall prevail and the total corrected; and
- 29.3 If there is a discrepancy between the amount expressed in words and figures, the amount in words shall prevail, subject to sub clause 29.1 and 29.2 above.
- 29.4 If, as per the judgement of the purchaser, there is any such arithmetical discrepancy in a tender, the same will be suitably conveyed to the tenderer by registered / speed post. If the tenderer does not agree to the observation of the purchaser, the tender is liable to be ignored.

30. Discrepancy between original and copies of Tender

- 30.1 In case any discrepancy is observed between the text etc. of the original copy and that in the other copies of the same tender set, the text etc. of the original copy shall prevail. Here also, the purchaser will convey its observation suitably to the tenderer by register / speed post and, if the tenderer does not accept the purchaser's observation, that tender will be liable to be ignored.

31. Qualification Criteria

- 31.1 Tenders of the tenderers, who do not meet the required Qualification Criteria prescribed in Section IX, will be treated as non - responsive and will not be considered further.

32. Deleted.

33. **Schedule-wise Evaluation**

33.1 In case the List of Requirements contains more than one schedule, the responsive tenders will be evaluated and compared separately for each schedule. The tender for a schedule will not be considered if the complete requirements prescribed in that schedule are not included in the tender. However, as already mentioned in GIT sub clause 13.2, the tenderers have the option to quote for any one or more schedules and offer discounts for combined schedules. Such discounts wherever applicable will be taken into account to determine the lowest evaluated cost for the purchaser in deciding the successful tenderer for each schedule, subject to tenderer(s) being responsive.

34. **Comparison of Tenders**

34.1 Unless mentioned otherwise in Section – III – Special Instructions to Tenderers and Section – VI – List of Requirements, the comparison of the responsive tenders shall be carried out for each item on the prices quoted at consignee site basis.

35. **Additional Factors and Parameters for Evaluation and Ranking of Responsive Tenders**

35.1 Further to GIT Clause 34 above, the purchaser's evaluation of a tender will include and take into account the following:

i) In the case of goods manufactured in India or goods of foreign origin already located in India, sales tax & other similar taxes and excise duty & other similar duties, Customs Duties, Service Tax, Works Contract Tax etc which will be contractually payable (to the tenderer), on the goods if a contract is awarded on the tenderer; and

ii) Deleted.

35.2 The purchaser's evaluation of tender will also take into account the additional factors, if any, incorporated in SIT in the manner and to the extent indicated therein.

35.3 The Purchaser reserves the right to give the price preference to small-scale sectors etc. and purchase preference to central public sector undertakings as per the instruction in vogue while evaluating, comparing and ranking the responsive tenders.

36. **Tenderer's capability to perform the contract**

36.1 The purchaser, through the above process of tender scrutiny and tender evaluation will determine to its satisfaction whether the tenderer, whose tender has been determined as the lowest evaluated responsive tender is eligible, qualified and capable in all respects to perform the contract satisfactorily. If, there is more than one schedule in the List of Requirements, then, such determination will be made separately for each schedule.

36.2 The above-mentioned determination will, inter alia, take into account the tenderer's financial, technical and production capabilities for satisfying all the requirements of the purchaser as incorporated in the TE document. Such determination will be based upon scrutiny and examination of all relevant data and details submitted by the tenderer in its tender as well as such other allied information as deemed appropriate by the purchaser.

37. **Contacting the Purchaser**

37.1 From the time of submission of tender to the time of awarding the contract, if a tenderer needs to contact the purchaser for any reason relating to this tender enquiry and / or its tender, it should do so only in writing.

- 37.2 In case a tenderer attempts to influence the purchaser in the purchaser's decision on scrutiny, comparison & evaluation of tenders and awarding the contract, the tender of the tenderer shall be liable for rejection in addition to appropriate administrative actions being taken against that tenderer, as deemed fit by the purchaser.

G. AWARD OF CONTRACT

38. Purchaser's Right to accept any tender and to reject any or all tenders

- 38.1 The purchaser reserves the right to accept in part or in full any tender or reject any or more tender(s) without assigning any reason or to cancel the tendering process and reject all tenders at any time prior to award of contract, without incurring any liability, whatsoever to the affected tenderer or tenderers.

39. Award Criteria

- 39.1 Subject to GIT clause 38 above, the contract will be awarded to the lowest evaluated responsive tenderer decided by the purchaser in terms of GIT Clause 36.

40. Variation of Quantities at the Time of Award/ Currency of Contract

- 40.1 At the time of awarding the contract, the purchaser reserves the right to increase or decrease by up to twenty five (25) per cent, the quantity of goods and services mentioned in the schedule (s) in the "List of Requirements" (rounded of to next whole number) without any change in the unit price and other terms & conditions quoted by the tenderer.
- 40.2 If the quantity has not been increased at the time of the awarding the contract, the purchaser reserves the right to increase by up to twenty five (25) per cent, the quantity of goods and services mentioned in the contract (rounded of to next whole number) without any change in the unit price and other terms & conditions mentioned in the contract, during the currency of the contract after one year from the Date of Notification of Award.

41. Notification of Award

- 41.1 Before expiry of the tender validity period, the purchaser will notify the successful tenderer(s) in writing, by registered/speed post or by fax/telex/cable (to be confirmed by registered/speed post) that its tender for goods & services, which have been selected by the purchaser, has been accepted, also briefly indicating therein the essential details like description, specification and quantity of the goods & services and corresponding prices accepted. The successful tenderer must furnish to the purchaser the required performance security within thirty days from the date of dispatch of this notification, failing which the EMD will be forfeited and the award will be cancelled. Relevant details about the performance security have been provided under GCC Clause 5 under Section IV.
- 41.2 The Notification of Award shall constitute the conclusion of the Contract.

42. Issue of Contract

- 42.1 Promptly after notification of award, the Purchaser/Consignee will mail the contract form (as per Section XVI) duly completed and signed, in duplicate, to the successful tenderer by registered / speed post.

- 42.2 Within twenty one days from the date of the contract, the successful tenderer shall return the original copy of the contract, duly signed and dated, to the Purchaser/Consignee by registered / speed post.
- 42.3 The Purchaser/Consignee reserves the right to issue the Notification of Award consignee wise.
- 43. Non-receipt of Performance Security and Contract by the Purchaser/Consignee**
- 43.1 Failure of the successful tenderer in providing performance security and / or returning contract copy duly signed in terms of GIT clauses 41 and 42 above shall make the tenderer liable for forfeiture of its EMD and, also, for further actions by the Purchaser/Consignee against it as per the clause 24 of GCC – Termination of default.
- 44. Return of EMD**
- 44.1 The earnest money of the successful tenderer and the unsuccessful tenderers will be returned to them without any interest, whatsoever, in terms of GIT Clause 19.6.
- 45. Publication of Tender Result**
- 45.1 The name and address of the successful tenderer(s) receiving the contract(s) will be mentioned in the notice board/bulletin/web site of the purchaser.
- 46. Corrupt or Fraudulent Practices**
- 46.1 It is required by all concerned namely the Consignee/Tenderers/Suppliers etc to observe the highest standard of ethics during the procurement and execution of such contracts. In pursuance of this policy, the Purchaser: -
- (a) defines, for the purposes of this provision, the terms set forth below as follows:
- (i) “corrupt practice” means the offering, giving, receiving or soliciting of any thing of value to influence the action of a public official in the procurement process or in contract execution; and
- (ii) “fraudulent practice” means a misrepresentation of facts in order to influence a procurement process or the execution of a contract to the detriment of the Purchaser, and includes collusive practice among Tenderers (prior to or after Tender submission) designed to establish Tender prices at artificial non-competitive levels and to deprive the Purchaser of the benefits of free and open competition;
- (b) will reject a proposal for award if it determines that the Tenderer recommended for award has engaged in corrupt or fraudulent practices in competing for the contract in question;
- (c) will declare a firm ineligible, either indefinitely or for a stated period of time, to be awarded a contract by the purchaser if it at any time determines that the firm has engaged in corrupt or fraudulent practices in competing for, or in executing the contract.

SECTION - III

SPECIAL INSTRUCTIONS TO TENDERERS (SIT)

The following Special Instructions to Tenderers will apply for this purchase. These special instructions will modify/substitute/supplement the corresponding General Instructions to Tenderers (GIT) incorporated in Section II.

In case of any conflict between the provision in the GIT and that in the SIT, the provision contained in the SIT shall prevail.

- A Preamble**
No Change
- B TE documents**
No Change
- C Preparation of Tenders**
No Change
- D Submission of Tenders**
No Change
- E Tender Opening**
No Change
- F Scrutiny and Evaluation of Tenders**
No Change
- G Award of Contract**
No Change

SECTION - IV
GENERAL CONDITIONS OF CONTRACT (GCC)

TABLE OF CLAUSES

Sl No.	Topic	Page No.
1	Application	26
2	Use of contract documents and information	26
3	Patent Rights	26
4	Country of Origin	26
5	Performance Security	26
6	Technical Specifications and Standards	27
7	Packing and Marking	27
8	Inspection, Testing and Quality Control	28
9	Terms of Delivery	30
10	Transportation of Goods	30
11	Insurance	30
12	Spare parts	31
13	Incidental services	31
14	Distribution of Dispatch Documents for Clearance/Receipt of Goods	31
15	Warranty	31
16	Assignment	32
17	Sub Contracts	32
18	Modification of contract	32
19	Prices	32
20	Taxes and Duties	33
21	Terms and mode of Payment	33
22	Delay in the supplier's performance	34
23	Liquidated Damages	35
24	Termination for default	35
25	Termination for insolvency	36
26	Force Majeure	36
27	Termination for convenience	36
28	Governing language	37
29	Notices	37
30	Resolution of disputes	37
31	Applicable Law	37
32	General/Miscellaneous Clauses	37

GENERAL CONDITIONS OF CONTRACT (GCC)

1. Application

1.1 The General Conditions of Contract incorporated in this section shall be applicable for this purchase to the extent the same are not superseded by the Special Conditions of Contract prescribed under Section V, List of requirements under Section VI and Technical Specification under Section VII of this document.

2. Use of contract documents and information

2.1 The supplier shall not, without the purchaser's prior written consent, disclose the contract or any provision thereof including any specification, drawing, sample or any information furnished by or on behalf of the purchaser in connection therewith, to any person other than the person(s) employed by the supplier in the performance of the contract emanating from this TE document. Further, any such disclosure to any such employed person shall be made in confidence and only so far as necessary for the purposes of such performance for this contract.

2.2 Further, the supplier shall not, without the purchaser's prior written consent, make use of any document or information mentioned in GCC sub-clause 2.1 above except for the sole purpose of performing this contract.

2.3 Except the contract issued to the supplier, each and every other document mentioned in GCC sub-clause 2.1 above shall remain the property of the purchaser and, if advised by the purchaser, all copies of all such documents shall be returned to the purchaser on completion of the supplier's performance and obligations under this contract.

3. Patent Rights

3.1 The supplier shall, at all times, indemnify and keep indemnified the purchaser, free of cost, against all claims which may arise in respect of goods & services to be provided by the supplier under the contract for infringement of any intellectual property rights or any other right protected by patent, registration of designs or trademarks. In the event of any such claim in respect of alleged breach of patent, registered designs, trade marks etc. being made against the purchaser, the purchaser shall notify the supplier of the same and the supplier shall, at his own expenses take care of the same for settlement without any liability to the purchaser.

4. Country of Origin

4.1 All goods and services to be supplied and provided for the contract shall have the origin in India or in the countries with which the Government of India has trade relations.

4.2 The word "origin" incorporated in this clause means the place from where the goods are mined, cultivated, grown, manufactured, produced or processed or from where the services are arranged.

4.3 The country of origin may be specified in the Price Schedule

5. Performance Security

5.1 Within twenty one (21) days from date of the issue of notification of award by the Purchaser/Consignee, the supplier, shall furnish performance security to the Purchaser/Consignee for an amount equal to ten percent (10%) of the total value of the contract, valid up to sixty (60) days after the date of completion of all contractual obligations by the supplier, including the warranty obligations, initially valid for a period of minimum 30 months from the date of Notification of Award. Purchaser reserves the right to ask for Performance Guarantee extension if contractual obligations are not fulfilled

- 5.2 The Performance security shall be denominated in Indian Rupees or in the currency of the contract as detailed below:
- a) It shall be in any one of the forms namely Account Payee Demand Draft or Fixed Deposit Receipt drawn from any Scheduled bank in India or Bank Guarantee issued by a Scheduled bank in India, in the prescribed form as provided in section XV of this document in favour of the Purchaser/Consignee. The validity of the Fixed Deposit receipt or Bank Guarantee will be for a period up to sixty (60) days beyond Warranty Period.
- 5.3 In the event of any failure/default of the supplier with or without any quantifiable loss to the Government, the amount of the performance security is liable to be forfeited. The Administration Department may do the needful to cover any failure/default of the supplier with or without any quantifiable loss to the Government.
- 5.4 In the event of any amendment issued to the contract, the supplier shall, within twenty-one (21) days of issue of the amendment, furnish the corresponding amendment to the Performance Security (as necessary), rendering the same valid in all respects in terms of the contract, as amended.
- 5.5 Deleted.
- 5.6 Subject to GCC sub-clause 5.3 above, the Purchaser/Consignee will release the Performance Security without any interest to the supplier on completion of the supplier's all contractual obligations including the warranty obligations.

6. Technical Specifications and Standards

- 6.1 The Goods & Services to be provided by the supplier under this contract shall conform to the technical specifications and quality control parameters mentioned in 'Technical Specification' and 'Quality Control Requirements' under Sections VII and VIII of this document.

7. Packing and Marking

- 7.1 The packing for the goods to be provided by the supplier should be strong and durable enough to withstand, without limitation, the entire journey during transit including transshipment (if any), rough handling, open storage etc. without any damage, deterioration etc. As and if necessary, the size, weights and volumes of the packing cases shall also take into consideration, the remoteness of the final destination of the goods and availability or otherwise of transport and handling facilities at all points during transit up to final destination as per the contract.
- 7.2 The quality of packing, the manner of marking within & outside the packages and provision of accompanying documentation shall strictly comply with the requirements as provided in Technical Specifications and Quality Control Requirements under Sections VII and VIII and in SCC under Section V. In case the packing requirements are amended due to issue of any amendment to the contract, the same shall also be taken care of by the supplier accordingly.
- 7.3 Packing instructions:

Unless otherwise mentioned in the Technical Specification and Quality Control Requirements under Sections VII and VIII and in SCC under Section V, the supplier shall make separate packages for each consignee (in case there is more than one consignee

mentioned in the contract) and mark each package on three sides with the following with indelible paint of proper quality:

- a. contract number and date
- b. brief description of goods including quantity
- c. packing list reference number
- d. country of origin of goods
- e. consignee's name and full address and
- f. supplier's name and address

8. Inspection, Testing and Quality Control

- 8.1 The purchaser and/or its nominated representative(s) will, inspect and/or test the ordered goods and the related services to confirm their conformity to the contract specifications and other quality control details incorporated in the contract.
- 8.2 The Purchaser reserves the right for stage inspection during manufacturing process, pre-dispatch inspection or post-delivery inspection. The Purchaser as deemed fit shall resort to all these inspection or may waive off any of the inspection.
- 8.3 Stage Inspection: The Supplier shall offer semi-finished product without paint for stage inspection supported with invoice & test report of major raw material as per relevant specification standards.
- 8.4 Before resorting to Bulk Manufacturing, the supplier shall offer/send the prototype/actual finished sample for approval by Inspector. The approval of Samples shall be in respect of workmanship and finishing and shall be without prejudice to the rights of purchaser/user to get random testing of items during pre-dispatch inspection or from the actual lot offered. In the event of the failure of the supplier to deliver the sample by the date specified in the contract or any other date agreed by the purchaser or in the event of rejection of the sample second time, the purchaser shall be entitled to cancel the contract and purchase the stores at the risk and cost of the supplier
- 8.5 In case the contract stipulates pre-despatch inspection of the ordered goods at supplier's premises, the supplier shall put up the goods for such inspection to the purchaser's inspector well ahead of the contractual delivery period, so that the purchaser's inspector is able to complete the inspection within the contractual delivery period.
- 8.6 The Inspector shall have full and free access at any time during the execution of the contract to the Supplier's works for satisfying himself that the goods are being manufactured in accordance with the specifications mentioned in the Contract, and he may require the Supplier to make arrangements for inspection of the goods or any part thereof or any material at his premises or at any other place specified by the Inspector and if the Supplier has been permitted to employ the services of a sub-Supplier, he shall in his contract with the sub-Supplier, serve to the Inspector a similar right, provided, however, such inspection shall not preclude the purchaser/inspection authority from re-inspection of the goods after they have been inspected by the Inspector for the purpose aforesaid. The decision of the purchaser/inspection authority in this regard shall be final and binding on the Supplier. All terms and conditions of the contract as they apply to the inspection shall also apply to the re-inspection.

The Supplier shall provide, without any extra charge, all materials, tools, labour and assistance of every kind which the Inspector may demand of him for any test, and examination, which he shall require to be made on the Supplier's premises and the Supplier shall bear and pay all costs attendant thereon. If the Supplier fails to comply with conditions aforesaid, the Inspector shall, in his sole judgement, be entitled to remove for test and examination all or any of the goods manufactured by the Supplier to any premises other than his (Supplier's) and in all such cases the Supplier shall bear the cost of transport and/or carrying out such tests elsewhere. A certificate in writing of the Inspector, that the Supplier has failed to provide the facilities and the means for test and examination, shall be final.

The Supplier shall also provide and deliver for test, free of charge, at such place other than his premises as the Inspector may specify such material or goods as he may require for tests for which Supplier does not have the facilities or for special/independent tests.

The Inspector shall have the right to put all the goods or materials forming part of the same or any part thereof to such tests as he may think fit and proper. The Supplier shall not be entitled to object on any ground whatsoever to the method of testing adopted by the Inspector.

- 8.7 If during such inspections and tests the contracted goods fail to conform to the required specifications and standards, the purchaser's inspector may reject them and the supplier shall either replace the rejected goods or make all alterations necessary to meet the specifications and standards, as required, free of cost to the purchaser and resubmit the same to the purchaser's inspector for conducting the inspections and tests again.
- 8.8 If the supplier tenders the goods to the purchaser's inspector for inspection at the last moment without providing reasonable time to the inspector for completing the inspection within the contractual delivery period, the inspector may carry out the inspection and complete the formality beyond the contractual delivery period at the risk and expense of the supplier. The fact that the goods have been inspected after the contractual delivery period will not have the effect of keeping the contract alive and this will be without any prejudice to the legal rights and remedies available to the purchaser under the terms & conditions of the contract.
- 8.9 Goods accepted by the purchaser/consignee and/or its inspector at initial inspection and in final inspection in terms of the contract shall in no way dilute purchaser's/consignee's right to reject the same later, if found deficient in terms of the warranty clause of the contract, as incorporated under GCC Clause 15.
- 8.10 The Purchaser's Inspector reserves the right to may draw samples through random sampling method after receiving the finished goods at destination. All the supplies shall be accompanied with the Manufacturer's certificate that the material conforms to the specifications

Further to above if on the goods being rejected by the Inspector or consignee at the destination, the Supplier fails to make satisfactory supplies within the stipulated period of delivery the Purchaser shall be at liberty to :

- (i) Require the Supplier to replace the rejected goods forthwith but in any event not later than a period of 30 days from the date of rejection and the Supplier shall bear all cost of such

replacement, including freight, if any, on such replacing and replaced goods but without being entitled to any extra payment on that or any other account.

- (ii) Purchase or authorize the purchase of quantity of the goods rejected or goods of a similar description when goods exactly complying with particulars are not in the opinion of the Purchaser, which shall be final, readily available without notice to the Supplier at his risk and cost and without affecting the Supplier's liability as regards the supply of any further installment due under the contract, or
- (iii) Cancel the contract and purchase or authorise the purchase of the goods or goods of a similar description (when goods exactly complying with particulars are not in the opinion of the Purchaser, which shall be final, readily available) at the risk and cost of the Supplier.
- (iv) The Inspector shall have the power:-
 - (a) before any goods or part thereof are submitted for inspection to certify that they cannot be in accordance with the contract owing to the adoption of any unsatisfactory method of manufacture.
 - (b) to reject any goods submitted as not being in accordance with particulars.
 - (c) to reject the whole of the instalment tendered for inspection, if after inspection of such portion thereof as he may in his discretion think fit, he is satisfied that the same is unsatisfactory.
 - (d) to demand all costs incurred in the inspection and/or test. Cost of test shall be assessed at the rate charged by the Laboratory to private persons for similar work. However if goods are accepted all cost incurred shall be born by the Purchaser.
 - (e) To mark the rejected goods with a rejection mark so that they may be easily identified if re-submitted.

Inspector's decision as regards the rejection shall be final and binding on the Supplier.

9. Terms of Delivery

9.1 Goods shall be delivered by the supplier in accordance with the terms of delivery specified in the contract.

10. Transportation of Goods

10.1 Deleted.

10.2 Instructions for transportation of domestic goods including goods already imported by the supplier under its own arrangement:

In case no instruction is provided in this regard in the SCC, the supplier will arrange transportation of the ordered goods as per its own procedure.

11. Insurance:

11.1 Unless otherwise instructed in the SCC, the supplier shall make arrangements for insuring the goods against loss or damage incidental to manufacture or acquisition, transportation, storage and delivery in the following manner:

- i) in case of supply of domestic goods on Consignee site basis, the supplier shall be responsible till the entire stores contracted for arrival in good condition at destination. The transit risk in this respect shall be covered by the Supplier by getting the stores duly

insured. The insurance cover shall be obtained by the Supplier and should be valid till 3 months after the receipt of goods by the Consignee.

ii) Deleted.

12. Deleted

13. Incidental services

13.1 Subject to the stipulation, if any, in the SCC (Section – V), List of Requirements (Section – VI) and the Technical Specification (Section – VII), the supplier shall be required to perform the following services.

Supplying Assembly drawings/pamphlets for assembly/upkeep of furniture if applicable.

14. Distribution of Dispatch Documents for Clearance/Receipt of Goods

The supplier shall send all the relevant despatch documents well in time to the Purchaser/Consignee to enable the Purchaser/Consignee clear or receive (as the case may be) the goods in terms of the contract.

Unless otherwise specified in the SCC, the usual documents involved and the drill to be followed in general for this purpose are as follows.

Within 24 hours of despatch, the supplier shall notify the purchaser, consignee, and others concerned if mentioned in the contract, the complete details of despatch and also supply the following documents to them by registered post / speed post (or as instructed in the contract):

- (i) Four copies of supplier's invoice showing contract number, goods description, quantity, unit price and total amount;
- (ii) Two copies of packing list identifying contents of each package;
- (iii) Inspection certificate issued by the nominated Inspection agency, if any.
- (iv) Certificate of origin;
- (v) Insurance Certificate as per GCC Clause 11.
- (viii) Manufacturers/supplier's warranty certificate & in-house inspection certificate.

15. Warranty

15.1 The supplier warrants comprehensively that the goods supplied under the contract is new, unused and incorporate all recent improvements in design and materials unless prescribed otherwise by the purchaser in the contract. The supplier further warrants that the goods supplied under the contract shall have no defect arising from design, materials or workmanship or from any act or omission of the supplier that may develop under normal use of the supplied goods under the conditions prevailing in India.

15.2 **The on-site replacement warranty shall remain valid for a period of 24 Months** from the date of recording of acceptance of goods at site.

15.3 In case of any claim arising out of this warranty, the Purchaser/Consignee shall promptly notify the same in writing to the supplier. The period of the warranty will be as per G.C.C clause number 15.2 above irrespective of any other period mentioned elsewhere in the bidding documents.

15.4 Upon receipt of such notice, the supplier shall, within 10 days replace the defective goods free of cost, at the ultimate destination. The supplier shall take over the replaced goods after providing their replacements and no claim, whatsoever shall lie on the purchaser for such

replaced goods thereafter. The penalty clause for non replacement will be applicable as per tender conditions.

- 15.5 In the event of replacement of defective goods during the warranty period, the warranty for the replaced goods shall be extended for a further period as mentioned under Clause 15.2 to the date such goods starts functioning to the satisfaction of the purchaser.
- 15.6 If the supplier, having been notified, fails to respond to take action to replace the defect(s) within 10 days the purchaser may proceed to take such remedial action(s) as deemed fit at the risk and expense of the supplier and without prejudice to other contractual rights and remedies, which the purchaser may have against the supplier.
- 15.7 During Warranty period, the supplier is required to visit at each consignee's site at least once in 4 months commencing from the date of delivery of the goods for preventive maintenance of the goods.
- 15.8 Deleted.
- 15.9 Deleted.
- 15.10 Deleted.

16. Assignment

- 16.1 The Supplier shall not assign, either in whole or in part, its contractual duties, responsibilities and obligations to perform the contract, except with the Purchaser's prior written permission.

17. Deleted.

18. Modification of contract

- 18.1 If necessary, the purchaser may, by a written order given to the supplier at any time during the currency of the contract, amend the contract by making alterations and modifications within the general scope of contract in any one or more of the following:

- a) Specifications, drawings, designs etc. where goods to be supplied under the contract are to be specially manufactured for the purchaser,
- b) Mode of packing,
- c) Incidental services to be provided by the supplier
- d) Mode of despatch,
- e) Place of delivery, and
- f) Any other area(s) of the contract, as felt necessary by the purchaser depending on the merits of the case.

- 18.2 In the event of any such modification/alteration causing increase or decrease in the cost of goods and services to be supplied and provided, or in the time required by the supplier to perform any obligation under the contract, an equitable adjustment shall be made in the contract price and/or contract delivery schedule, as the case may be, and the contract amended accordingly. If the supplier doesn't agree to the adjustment made by the Purchaser/Consignee, the supplier shall convey its views to the Purchaser/Consignee within twenty-one days from the date of the supplier's receipt of the Purchaser's/Consignee's amendment / modification of the contract.

19. Prices

- 19.1 Prices to be charged by the supplier for supply of goods and provision of services in terms of the contract shall not vary from the corresponding prices quoted by the supplier in its tender and incorporated in the contract except for any price adjustment authorised in the SCC.

20. Taxes and Duties

- 20.1 Supplier shall be entirely responsible for all taxes, duties, fees, levies etc. incurred until delivery of the contracted goods to the purchaser.
- 20.2 Further instruction, if any, shall be as provided in the SCC.

21. Terms and Mode of Payment

21.1 Payment Terms

Payment shall be made in Indian Rupees as specified in the contract subject to recoveries, if any, by way of liquidated damages or any other charges as per terms & conditions of contract in the following manner.

a) On delivery:

75% payment of the contract price shall be paid on receipt of goods in good condition at the consignee premises and upon the submission of the following documents:

- (i) Four copies of supplier's invoice showing contract number, goods description, quantity, unit price and total amount;
- (ii) Consignee Receipt Certificate as per Section XVII in original issued by the authorized representative of the consignee;
- (iii) Two copies of packing list identifying contents of each package;
- (iv) Inspection certificate issued by the nominated Inspection agency, if any.
- (v) Insurance Certificate as per GCC Clause 11;

b) On Acceptance:

Balance 25% payment would be made against 'Final Acceptance Certificate' as per Section XVIII of goods to be issued by the consignees subject to recoveries, if any, either on account of non-rectification of defects/deficiencies not attended by the Supplier or otherwise.

- 21.2 The supplier shall not claim any interest on payments under the contract.
- 21.3 Where there is a statutory requirement for tax deduction at source, such deduction towards income tax and other tax as applicable will be made from the bills payable to the Supplier at rates as notified from time to time.
- 21.4 Deleted.
- 21.5 The payment shall be made in the currency /currencies authorised in the contract.
- 21.6 The supplier shall send its claim for payment in writing, when contractually due, along with relevant documents etc., duly signed with date, to respective consignees.
- 21.7 While claiming payment, the supplier is also to certify in the bill that the payment being claimed is strictly in terms of the contract and all the obligations on the part of the supplier for claiming that payment has been fulfilled as required under the contract.
- 21.8 While claiming reimbursement of duties, taxes etc. (like sales tax, excise duty, custom duty) from the Purchaser/Consignee, as and if permitted under the contract, the supplier shall also

certify that, in case it gets any refund out of such taxes and duties from the concerned authorities at a later date, it (the supplier) shall refund to the Purchaser/Consignee forthwith.

- 21.9 In case where the supplier is not in a position to submit its bill for the balance payment for want of receipted copies of Inspection Note from the consignee and the consignee has not complained about the non-receipt, shortage, or defects in the supplies made, balance amount will be paid by the paying authority without consignee's receipt certificate after three months from the date of the preceding part payment for the goods in question, subject to the following conditions:
- (a) The supplier will make good any defect or deficiency that the consignee (s) may report within six months from the date of despatch of goods.
 - (b) Delay in supplies, if any, has been regularized.
 - (c) The contract price where it is subject to variation has been finalized.
 - (d) The supplier furnishes the following undertakings:

"I/We, _____ certify that I/We have not received back the Inspection Note duly receipted by the consignee or any communication from the purchaser or the consignee about non-receipt, shortage or defects in the goods supplied. I/We _____ agree to make good any defect or deficiency that the consignee may report within three months from the date of receipt of this balance payment.

22. Delay in the supplier's performance

- 22.1 The supplier shall deliver of the goods and perform the services under the contract within the time schedule specified by the Purchaser/Consignee in the List of Requirements and as incorporated in the contract.
- 22.2 Subject to the provision under GCC clause 26, any unexcused delay by the supplier in maintaining its contractual obligations towards delivery of goods and performance of services shall render the supplier liable to any or all of the following sanctions:
- (i) imposition of liquidated damages,
 - (ii) forfeiture of its performance security and
 - (iii) termination of the contract for default.
- 22.3 If at any time during the currency of the contract, the supplier encounters conditions hindering timely delivery of the goods and performance of services, the supplier shall promptly inform the Purchaser/Consignee in writing about the same and its likely duration and make a request to the Purchaser/Consignee for extension of the delivery schedule accordingly. On receiving the supplier's communication, the Purchaser/Consignee shall examine the situation as soon as possible and, at its discretion, may agree to extend the delivery schedule, with or without liquidated damages for completion of supplier's contractual obligations by issuing an amendment to the contract.
- 22.4 When the period of delivery is extended due to unexcused delay by the supplier, the amendment letter extending the delivery period shall, inter alia contain the following conditions:
- (a) The Purchaser/Consignee shall recover from the supplier, under the provisions of the clause 23 of the General Conditions of Contract, liquidated damages on the goods and

services, which the Supplier has failed to deliver within the delivery period stipulated in the contract.

- (b) That no increase in price on account of any ground, whatsoever, including any stipulation in the contract for increase in price on any other ground and, also including statutory increase in or fresh imposition of customs duty, excise duty, sales tax/ VAT, Service Tax and Works Contract Tax or on account of any other tax or duty which may be levied in respect of the goods and services specified in the contract, which takes place after the date of delivery stipulated in the contract shall be admissible on such of the said goods and services as are delivered and performed after the date of the delivery stipulated in the contract.
- (c) But nevertheless, the Purchaser/Consignee shall be entitled to the benefit of any decrease in price on account of reduction in or remission of customs duty, excise duty, sales tax/ VAT, Service Tax and Works Contract Tax or any other duty or tax or levy or on account of any other grounds, which takes place after the expiry of the date of delivery stipulated in the contract.

22.5 The supplier shall not dispatch the goods after expiry of the delivery period. The supplier is required to apply to the Purchaser/Consignee for extension of delivery period and obtain the same before despatch. In case the supplier dispatches the goods without obtaining an extension, it would be doing so at its own risk and no claim for payment for such supply and/or any other expense related to such supply shall lie against the purchaser.

23. Liquidated damages

23.1 Subject to GCC clause 26, if the supplier fails to deliver any or all of the goods or fails to perform the services within the time frame(s) incorporated in the contract, the Purchaser/Consignee shall, without prejudice to other rights and remedies available to the Purchaser/Consignee under the contract, deduct from the contract price, as liquidated damages, a sum equivalent to 0.5% per week of delay or part thereof on delayed supply of goods and/or services until actual delivery or performance subject to a maximum of 10% of the contract price. Once the maximum is reached Purchaser/Consignee may consider termination of the contract as per GCC 24.

During the above-mentioned delayed period of supply and / or performance, the conditions incorporated under GCC sub-clause 22.4 above shall also apply.

24. Termination for default

24.1 The Purchaser/Consignee, without prejudice to any other contractual rights and remedies available to it (the Purchaser/Consignee), may, by written notice of default sent to the supplier, terminate the contract in whole or in part, if the supplier fails to deliver any or all of the goods or fails to perform any other contractual obligation(s) within the time period specified in the contract, or within any extension thereof granted by the Purchaser/Consignee pursuant to GCC sub-clauses 22.3 and 22.4.

24.2 In the event of the Purchaser/Consignee terminating the contract in whole or in part, pursuant to GCC sub-clause 24.1 above, the Purchaser/Consignee may procure goods and/or services similar to those cancelled, with such terms and conditions and in such manner as it deems fit

and the supplier shall be liable to the Purchaser/Consignee for the extra expenditure, if any, incurred by the Purchaser/Consignee for arranging such procurement.

24.3 Unless otherwise instructed by the Purchaser/Consignee, the supplier shall continue to perform the contract to the extent not terminated.

25. Termination for insolvency

25.1 If the supplier becomes bankrupt or otherwise insolvent, the purchaser reserves the right to terminate the contract at any time, by serving written notice to the supplier without any compensation, whatsoever, to the supplier, subject to further condition that such termination will not prejudice or affect the rights and remedies which have accrued and / or will accrue thereafter to the Purchaser/Consignee.

26. Force Majeure

26.1 Notwithstanding the provisions contained in GCC clauses 22, 23 and 24, the supplier shall not be liable for imposition of any such sanction so long the delay and/or failure of the supplier in fulfilling its obligations under the contract is the result of an event of Force Majeure.

26.2 For purposes of this clause, Force Majeure means an event beyond the control of the supplier and not involving the supplier's fault or negligence and which is not foreseeable and not brought about at the instance of , the party claiming to be affected by such event and which has caused the non – performance or delay in performance. Such events may include, but are not restricted to, acts of the Purchaser/Consignee either in its sovereign or contractual capacity, wars or revolutions, hostility, acts of public enemy, civil commotion, sabotage, fires, floods, explosions, epidemics, quarantine restrictions, strikes excluding by its employees, lockouts excluding by its management, and freight embargoes.

26.3 If a Force Majeure situation arises, the supplier shall promptly notify the Purchaser/Consignee in writing of such conditions and the cause thereof within twenty one days of occurrence of such event. Unless otherwise directed by the Purchaser/Consignee in writing, the supplier shall continue to perform its obligations under the contract as far as reasonably practical, and shall seek all reasonable alternative means for performance not prevented by the Force Majeure event.

26.4 If the performance in whole or in part or any obligation under this contract is prevented or delayed by any reason of Force Majeure for a period exceeding sixty days, either party may at its option terminate the contract without any financial repercussion on either side.

26.5 In case due to a Force Majeure event the Purchaser/Consignee is unable to fulfil its contractual commitment and responsibility, the Purchaser/Consignee will notify the supplier accordingly and subsequent actions taken on similar lines described in above sub-paragraphs.

27. Termination for convenience

27.1 The Purchaser/Consignee reserves the right to terminate the contract, in whole or in part for its (Purchaser's/Consignee 's) convenience, by serving written notice on the supplier at any time during the currency of the contract. The notice shall specify that the termination is for the convenience of the Purchaser/Consignee. The notice shall also indicate interalia, the extent to which the supplier's performance under the contract is terminated, and the date with effect from which such termination will become effective.

27.2 The goods and services which are complete and ready in terms of the contract for delivery and performance within thirty days after the supplier's receipt of the notice of termination

shall be accepted by the Purchaser/Consignee following the contract terms, conditions and prices. For the remaining goods and services, the Purchaser/Consignee may decide:

- a) To get any portion of the balance completed and delivered at the contract terms, conditions and prices; and / or
- b) To cancel the remaining portion of the goods and services and compensate the supplier by paying an agreed amount for the cost incurred by the supplier towards the remaining portion of the goods and services.

28. Governing language

28.1 The contract shall be written in English language following the provision as contained in GIT clause 4. All correspondence and other documents pertaining to the contract, which the parties exchange, shall also be written accordingly in that language.

29. Notices

29.1 Notice, if any, relating to the contract given by one party to the other, shall be sent in writing or by cable or telex or facsimile and confirmed in writing. The procedure will also provide the sender of the notice, the proof of receipt of the notice by the receiver. The addresses of the parties for exchanging such notices will be the addresses as incorporated in the contract.

29.2 The effective date of a notice shall be either the date when delivered to the recipient or the effective date specifically mentioned in the notice, whichever is later.

30. Resolution of disputes

30.1 If dispute or difference of any kind shall arise between the Purchaser/Consignee and the supplier in connection with or relating to the contract, the parties shall make every effort to resolve the same amicably by mutual consultations.

30.2 If the parties fail to resolve their dispute or difference by such mutual consultation within twenty-one days of its occurrence, then, unless otherwise provided in the SCC, either the Purchaser/Consignee or the supplier may give notice to the other party of its intention to commence arbitration, as hereinafter provided the applicable arbitration procedure will be as per the Arbitration and Conciliation Act, 1996 of India. In the case of a dispute or difference arising between the Purchaser/Consignee and a domestic Supplier relating to any matter arising out of or connected with the contract, such dispute or difference shall be referred to the sole arbitration of an officer in the Ministry of Law and Justice, appointed to be the arbitrator by Ministry of Health & Family Welfare or the Client. The award of the arbitrator shall be final and binding on the parties to the contract subject to the provision that the Arbitrator shall give reasoned award in case the value of claim in reference exceeds Rupees One Lac (Rs. 1,00,000/-)

30.3 Venue of Arbitration: The venue of arbitration shall be New Delhi, India.

31. Applicable Law

The contract shall be governed by and interpreted in accordance with the laws of India for the time being in force.

32. General/ Miscellaneous Clauses

32.1 Nothing contained in this Contract shall be constructed as establishing or creating between the parties, i.e. the Supplier/its Agent on the one side and the Purchaser on the other side, a relationship of master and servant or principal and agent.

- 32.2 Any failure on the part of any Party to exercise right or power under this Contract shall not operate as waiver thereof.
- 32.3 The Supplier shall notify the Purchaser/Consignee /the Government of India of any material change would impact on performance of its obligations under this Contract.
- 32.4 Each member/constituent of the Supplier/its Agent, in case of consortium shall be **jointly and severally liable** to and responsible for all obligations towards the Purchaser/Consignee/Government for performance of contract/ under the Contract.
- 32.5 The Supplier/its Agent shall at all times, indemnify and keep indemnified the Purchaser/Government of India against all claims/damages etc. for any infringement of any Intellectual Property Rights (IPR) while providing its services under the Contract.
- 32.6 The Supplier/its Agent shall, at all times, indemnify and keep indemnified the Purchaser/Consignee/Government of India against any claims in respect of any damages or compensation payable in consequences of any accident or injury sustained or suffered by its employees or agents or by any other third party resulting from or by any action, omission or operation conducted by or on behalf of the supplier/its associate/affiliate etc.
- 32.7 All claims regarding indemnity shall survive the termination or expiry of the contract.

SECTION – V

SPECIAL CONDITIONS OF CONTRACT (SCC)

The following Special Conditions of Contract (SCC) will apply for this purchase. The corresponding clauses of General Conditions of Contract (GCC) relating to the SCC stipulations have also been incorporated below.

These Special Conditions will modify/substitute/supplement the corresponding (GCC) clauses. Whenever there is any conflict between the provision in the GCC and that in the SCC, the provision contained in the SCC shall prevail.

SECTION - VI**LIST OF REQUIREMENTS****Part I**

Item Sl.No	Name of Item	Qty. (Nos.)
1	EXAMINATION COUCH	6
2	TREATMENT COUCH	6
3	FOWLER BED	50
4	WHEEL CHAIR	4
5	ARMLESS CHAIR	76
6	BED SIDE CABINET	51
7	CAFETARIA CHAIR	48
8	CAFETARIA TABLE (1.2M x 1.2M)	8
9	CONFERENCE CHAIR	34
10	CONFERENCE TABLE 24 SEATER	1
11	COT WITH MATTRESS - SINGLE	6
12	DOUBLE SIDED BOOK RACK	5
13	EXECUTIVE CHAIR	28
14	EXECUTIVE TABLE	35
15	LAB MODULAR TABLE WITH SINK	4
16	LAB STOOL WITH BACK REST	50
17	LECTURE HALL STUDENT CHAIR	25
18	MODULAR WORK STATIONS	8
19	OPEN STORAGE RACK	50
20	SOFA SINGLE SEATER	10
21	SOFA 3 SEATER	4
22	STAFF CHAIR	57
23	STORAGE CUPBOARD WITH LOCK	33
24	VISITOR CHAIR	50

Part II: Required Delivery Schedule:

- i. The tenderer/supplier is required to have capability to supply bulk/large quantity in shortest time.
- ii. The quantity mentioned in List of requirement must be supplied within **Ninety Days** of Notification of Award or within 60 days from the date of approval of advance sample.
- iii. The finished advance sample shall be given within **Twenty One days** from the Date of Notification of Award before resorting to bulk manufacturing/supplies.

Note: The Purchaser/Consignee reserves the right to extend the delivery period up to one year from the date of NOA at its discretion.

Part III: Scope of Incidental Services:

As specified in GCC Clause 13

Part IV:

Deleted

Part V:

Deleted

Part VI:

Required Terms of Delivery and Destination

Free at Consignee's Site

Destination/Consignee details are given in Section XXI

SECTION-VII

GENERAL APPENDEX TO SPECIFICATIONS

- Note 1:** Tenderer's attention is drawn to GIT clause 18 and clause 11. The tenderer is to provide the required details, information, confirmations, etc. accordingly failing which it's tender is liable to be ignored.
- Note 2 :** All metal Structure would be treated by seven tanks process for Powder Coating Paint i.e. Digressing (1st Tank), Water Rinsing(2nd Tank), Dirusting By Acid (3rd Tank), Water rinsing (4th Tank), Phosphating (5th Tank), Water Rinsing (6th Tank), Passivation (7th Tank) respectively with non electrolytic deep process to produce a protective oxide coating for smooth surface with matt finish anticorrosive automated powder Coating Paint of thickness 40-60 microns and over baked for high resistance to scratch, Chemical, thermal ad mechanical stress. Open ends of the steel pipes would be covered by Nylon caps and buffers.
- Note 3:** Wherever plywood are required BWR termite proof ISO 9000:14001 grade ISI marked hot pressed commercial ply of the desired thickness should be used.
- Note 4:** Wherever springs are required the suppliers should supply this furniture with Heavy Duty springs of desired thickness.
- Note 5:** The picture provided in the specification is for illustration purposes only and not to scale.
- Note 6: Warranty:**
Two Years on-site replacement Warranty as per Conditions of Contract of the TE document for complete Stores from the date of recording of acceptance of stores at site.
- Note 7: After Sales Service:**
After sales service should be available at the city of Hospital/Institution/Medical College on 24 (hrs) X 7 (days) X 365 (days) basis. Complaints should be attended properly. The service should be provided directly by the supplier or his authorised agent whose details shall be provided to the purchaser/consignee within one month from the date of award of contract.
- Note 8: Watch and Ward**
The supplier shall be responsible for watch and ward of all the works, equipment and various materials till complete handing over the works.
- Note 9: The following standards shall apply wherever applicable:**
- | | |
|----------|--|
| IS 2202 | Wooden flush door shutters (solid core type) particle board face panels and hard (part 2) board face panels. |
| (Part-I) | Operations and workmanship |
| (Part 2) | Schedule |

IS 2380	Methods of test for wood particle boards.
IS 5437	Figured, rolled and wired glass
IS 14900	Transparent float glass-specifications.
IS 277	Galvanized steel sheets (Plain or corrugated).
IS 737	Specification for wrought aluminium and aluminium alloy sheet and strips for general engineering purpose.
IS 801	Code of practice for use of cold formed light gauge steel structural members in general building construction.
IS 7178	Technical supply conditions for tapping screw.
IS8183	Bonded mineral wool.
IS 12118	Two parts polysulphide.
IS 12823, 1990	PLB, Pre-laminated particle board.
IS 13871, 1993	Powder coating specification.
IS 3087, 1985	Specification for wood particle boards for general purpose.
IS 2046, 1995	Decorative thermosetting synthetic resin banded laminated sheets specification.

INTERNATIONAL STANDARDS

AS1365	Standards for steel manufacturing
AS 1397	A steel sheet & steel hot-dipped zinc coated or aluminium zinc coated.
AS/NZS 2728	Pre finished/pre painted sheet metal product for interior/exterior building applications-performance requirement.
AS3566	Self drilling screws for building and construction industry.
BIFMA	The Business and Institutional Furniture Manufacturers' Association

Note 10: LIST OF RECOMMENDED MAKES OR MATERIALS FURNITURE WORKS

Sl. No	Material	Approved Make
1.	Paint	ICI/Asian Paints/Berger/Jenson & Nicholson/Nerolac
2.	Float Glass/ toughened glass	Modi Guard/Indo Asahi/Pilkington, St. Gobain
3.	Expansion Bolts	1. Hilti 2. Fischer
4.	Glazing Sealant	1. Dow Corning 2. GE Sealant 3. Wacker
5.	Plastic Laminated Board/medium Density Fibre Board	1. Nuwad 2. Duratuff 3. Shirdi
6.	Resin based Adhesive	1. Fevicol 2. Vamicol
7.	Pin-Up Board	1. Sitatex 2. Novapan 3. Greenlam 4. Marino
8.	Fire Retardant Paint	1. Navair

		2. Viper
9.	SS/Chrome Coated Hardware	1. Earl Bihari Pvt. Ltd. (EBCO) 2. Dorset 3. Ar Kay.
10.	Laminate	Sitatex/Novapan/Greenlam/ Marino
11.	Aluminium Alloy Extruded section	1. Hindalco 2. Indalco 3. Jindal
12.	Pre-laminated Particle Board (Exterior Grade) and Post Form Laminate	1. Sitatex 2. Novapan 3. Greenlam 4. Marino 5. Action Tesa 6. ASIS 7. Space Wood
13.	Fabric Protection	Fabguard / Scotchguard as approved
14.	Locks	Locks should be made of brass levers & lock springs should be made of phosphorous bronze. Lock keys shall be fabricated out of blank stainless steel sheets. Make -Godrej / Dorset ML-101 or equivalent with separate keyhole ring.
15.	Pivots, Handle bars etc.	Dorma, Dorset or equivalent in SS finish
16.	Brass/powder coated Hardware	Jarods, Palladium, Parmar, Earl Bihari / as approved

Note 11: A tolerance of $\pm 2\%$ subject to a maximum of 15 mm. shall be allowed in dimensions.

Note 12: In addition to the makes specified under Note:10, any other equivalent ISI mark make can also be used. The word “equivalent “would imply meeting the major critical parameters.

TECHNICAL SPECIFICATIONS

Item Sl. No. 1

EXAMINATION COUCH

1. Overall size: 1890 mm L x 560mm W x 840mm H. Fixed upholstered top 64mm thick in two sections.
2. Body frame work made from 20G. CRCA sheet and 20 mm x 40mm x 16 G MS. Rectangular Tubes, couch fitted with stainless steel legs.
3. Headrest adjustable on gas spring.
4. Upper section of box size 1220 mm L x 460 mm W x 630 mm H with three sliding drawers of size 320 mm L x 430 mm W x 75 mm H.
5. Lower section comprises of three cabinets of inside size 350mm L x 440 W mm x 430 H mm with separate doors & lock.
6. B.P. Apparatus tray made of 18 G MS sheet of size 350 mm L x 120 mm W X 20 mm H provided on a swinging rod rotating through a bush welded on the body of the couch.
7. Should have Sliding Inbuilt Step Stool.
8. All mild steel components should be thoroughly pre-treated chemically to remove rust and foreign matter like Grease, Oil etc. by dip tank process pretreatment system.
9. The treated Metal surface should have coating of Epoxy Polyester Powder with paint film thickness of 60 microns (minimum) and oven baked at 180 degree to 200 degree Centigrade to avoid contamination of the clean metal surface from dust particles.



Item Sl. No. 2
TREATMENT COUCH

1. Basic treatment couch
2. Upholstered Two-section well-padded top. Water proof cover
3. Size 180cm x 60cm with a fixed working height of 80cm.
4. Backrest is 67cm long and is easily adjustable for desired position.
5. Top of this treatment couch is fitted on painted heavy duty rectangular steel pipe frame and mounted on four, chrome plated, 37mm dia. tubular legs for stability.



Item Sl. No. 3
FOWLER BED

1. Overall size 2180mm L x 1010mm W x 600mm H.
2. Bed frame: size: 2095mm L x 920mm W.
3. The main frame should be made from 60mm x 30mm x 16 G ERW rectangular tubes.
4. Four sections top should be made from 18 G C.R.C.A. sheets uniformly perforated and should be suitably fitted to the main frame.
5. Back-rest and knee rest should be maneuvered by the screw mechanism with one common handle, welded with 31.7mm dia x 16 G ERW M. S.
6. Tube for linear movement in a 38mm dia x 16 G ERW M. S. cover tube which can be smoothly operated on thrust bearings.
7. Detachable Head and Leg Bows: Should be made from stainless steel 31.7mm dia x 18 G tube with laminated panels of approx. size 810mm L x 140mm wide x 14mm thick on stainless steel bracket.
8. The base frame should be fitted with non-rusting swivel castor wheels 125mm dia, 2 with brake, 2 without brakes castors housing and wheels made from high grade non floor staining synthetic materials with integrated thread guards wheel centre having precision ball bearing to run smoothly.
9. The bows should be mounted to the bed frame on welded brackets in such a way that bolt or nut should not appear on top surface of the bed frame.
10. Mattress of the bed should be made of high density foam which is more than 50 mm thick, with anti-microbial properties to prevent microbial growth of any kind. Cover should be water proof and very easy to clean.
11. Additional 10 % quantity of mattress should be supplied as spare.



Item Sl. No. 4
WHEEL CHAIR

1. Overall size: 670mm W x 1120mm D x 920mm H. approx.
2. Welded frame construction of round tubes.
3. Two solid rubber tyred bicycle wheels with brakes & self-propelling stainless steel hoops.
4. Minimum Frame size of round steel 22.2 x 18 G tubes and 19.05 x 18 G tubes. Mild steel tubular construction fitted with cushion seat and back.
5. Wheel chair is fitted with minimum 24" dia rim of bicycle wheel fitted on specially developed and heat treated axle with solid tyre in the rear.
6. In the front minimum 150mm dia castor wheels are fitted. In front of castor wheels, aluminum foot paddles are provided on adjustable brackets.
7. Two handles are provided with the hand grips. Brakes are provided on rear wheel to hold the chair to stop in 5 degree ramp.
8. All mild steel components should be thoroughly pre-treated chemically to remove rust and foreign matter like Grease, Oil etc. by dip tank process pretreatment system.
9. The treated Metal Surface should have coating of Epoxy Polyester Powder with paint film thickness of 60 microns (minimum) and oven baked at 180 degree to 200 degree Centigrade to avoid contamination of clean metal surface from dust particles.



Item Sl. No. 5
ARMLESS CHAIR



1. SEAT/BACK ASSEMBLY: The seat is made of moulded Polyurethane foam and 12mm thk Recycled composite board upholstered with replaceable fabric cover. The back is made of MS tubular frame insitu moulded with Polyurethane foam and upholstered with fabric cover. Back Size 45.0 cm. (W) x 47.0 cm. (H) Seat Size: 45.0 cm. (W) x 50.5 cm. (D)
2. POLYURETHANE FOAM: The Polyurethane foam is moulded with density = 45 ± 2 kg/m³ and Hardness for back foam is 16 (+0/-2) & that for seat foam is 20 (+/-2) at 25% compression.
3. TUBULAR FRAME STRUCTURE: The powder coated tubular frame structure is made of 48 mm x 18.5 mm x 2.5 mm thk M.S. ERW oblong tube.
4. Stackable chairs.
5. Assorted Colours.

Item Sl. No. 6
BEDSIDE CABINET



1. Material :ABS engineering plastic
2. Size:450*470*780mm
3. 1 drawer and 1 storage cabinet.
4. Hidden pull-out tray for cups & articles.
5. 2 towel holders (one on each side).

Item Sl. No. 7
CAFETARIA CHAIR



Seat & Back shell is injection moulded in Poly Propylene.

Tubular Frame in 19mm Dia stainless steel tube.

Dimensions:

Width : 52 cm

Depth : 55 cm

Height : 80 cm

Item Sl. No. 8
CAFETARIA TABLE(1.2Mx1.2M)

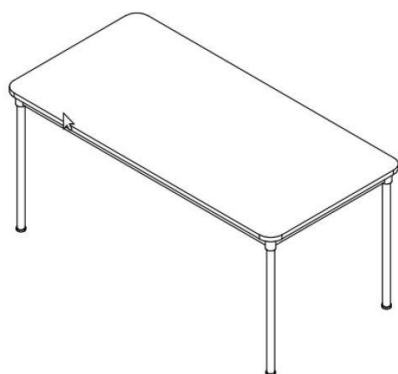

Work-Surface : PVC foiled 25mm Thick (± 1 mm)

Base Material : 25mm MDF board PU painted of 5H hardness with 75% gloss as per color chart, Combination color Graphics on the centre.

Understructure : Bend pipe understructure of MS. Powder coated. Pipe dia 38mm, 2mm thick. Fitted with top by SS machine screws. Table bottom have metal insert for better holding of screw.

Legs : 4 Glide Plastic Glide fixed at the understructure to prevent the damage of table top during stacking.

: PVC Membrane foil on top. .

Dimensions : Table out to out: 1200mm W x 1200mm D x 750mm H.

Item Sl. No. 9
CONFERENCE CHAIR



1. SEAT/BACK ASSEMBLY: The seat is made up of 1.2 cm. thick hot pressed plywood upholstered with fabric and moulded Polyurethane Foam. The back is made up 1.2 cm. thick hot pressed plywood upholstered with replaceable fabric upholstery covers and moulded polyurethane foam. The back ply and foam is designed with contoured lumber support for comfortable seating posture. Back Size 48cm.(W) X 64.5cm.(H). Seat Size 51.0cm.(W) X 48.0cm.(D)
2. POLYURETHANE FOAM: The polyurethane foam for seat and back is moulded with density = 45 +/-2 kg/m³ and Hardness = 20 +/- 2.
3. ARMRESTS (FIXED) :The armrest top is made of moulded polyurethane (P.U) and mounted on to a fixed type M.S. tubular armrest support chrome plated. The arm support has static vertical adjustment of +/-1.5cm.
4. FRONT PIVOT SYNCHRO MECHANISM: The mechanism is designed with the following features: 360° revolving type. Single point control. Front pivot for tilt with feet resting on ground ensuring more comfort. Tilt tension adjustment. 4-position locking with anti-shock feature. Seat back tilting ratio of 1:2 (11° Seat Tilt /22° back tilt).
5. FIXED BACKREST: The backrest consists of a fixed type mechanism i.e no back up/down adjustment.
6. PNEUMATIC HEIGHT ADJUSTMENT : The pneumatic height adjustment has an adjustment of 8-10 cm.
7. PEDESTAL ASSEMBLY : The pedestal is fabricated from steel, hard chrome plated and assembled with injection moulded black polypropylene hub cap and 5 nos. twin wheel castors (castor wheel dia. 5.0 cm). The pedestal is 66.0cm. Pitch-center dia. (76.0 cm with castors).
8. TWIN WHEEL CASTORS: The twin wheel castors are injection moulded in black Nylon.

Item Sl. No. 10
CONFERENCE TABLE -24 SEATER



Size	Dimensions (mms)	
Single Seater	760 W	600 D
Two Seater	1360 W	600 D
Half Round (2 Seater)	R 713	
Quarter Round (1 Seater)	R 713	
Work surface	Top thickness 37.6 (18mm + 18mm + 0.6 mm DL + 0.4mm Membrane) Edge profile Waterfall Edge 10mm radius on top edge and 5mm at bottom.	
Legs	Made from 36mm PPB (18+18) having a straight profile with half round edges and clad with 0.6mm thick Post Forming laminate. Overall thickness of leg is 37.2mm.	
Modesty Panel	Made from PLT (Prelaminated Twin) boards of 18mm thick.	
Wire Manager	Wire Carrier : Made from 0.6mm thick CRCA painted.	
Carrier Cover	Made of 12mm thk. MDF Painted all over.	
Substrate	MDF	
Skin	PVC Membrane foil (0.4mm thk) clad on the substrate MDF using PU glue for better adhesion. This foil is pre-coated with layer of polyurethane for better scratch resistance.	

Item Sl. No. 11**COT WITH MATTRESS - SINGLE**

The Single Cot Bed of dimensions 6'3" X 3' approximately.

The specifications are as follows :

Bed surface Dimension Width – 920mm, Length – 1900mm, Height – 450mm

Bed structure consists of metal frames made of Powder coated MS rectangular pipe 1.5mm thickness of 75mmX50mm

Height of head end from floor 800mm, W 100mm, Foot end height from floor 550mm made of 35mm board, laminated with 1.5mm thickness total edge binding with hot glued beading of matching colour. Bed fitted with polypropylene grommets. Bed made of 12mm ply wood screwed on frame reinforcement on 2 sections of rectangular pipe 16 SWG 25mmX25mm by welding.

Bed should be supplied with matching jute mattress to fit on above bed quilted with high density foam covered with cloth. Mattress should be at least 80mm thick

All metal parts should be powder coated.

Item Sl. No. 12
DOUBLE SIDED BOOK RACK

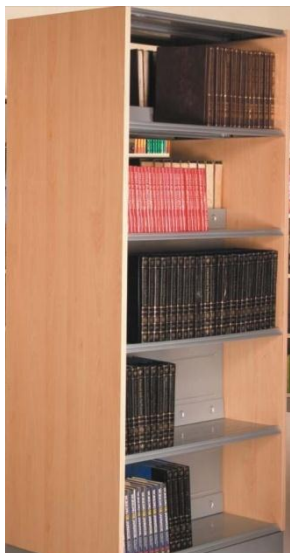

1. Size: Width: 925mm Main Unit/900mm Add On Unit , Height: 1890mm(Incl. 85mm Skirting)
Depth: 300mm
2. Rigid knockdown construction. Back panel up to the bottom of third rack for additional rigidity.
3. Material: Racks, Back Panel & Skirting: CRCA 0.8mm Thickness Side panels:25mm thick Prelaminated particle board (PLB) with laminate on both sides.
4. Finish: Metal panels: Epoxy Polyester Powder coated to the thickness of 50 microns (+/-10).
5. Stackability: The add-on units can be stacked width wise to form a bank of racks having common side panel.
6. Number of racks: Bottom plus four fixed racks. (Total 5 loading levels). Each rack is provided with stiffener at bottom for strength.
 - Uniformly Distributed Load Capacity per each full shelf is 80 Kg maximum.
7. Rack back stiffener At the rear side of the racks back stiffeners are provided. These are to support books on the rear side.
8. Label holder: Label Holder on each main unit to insert labels for identification.

Item Sl. No. 13
EXECUTIVE CHAIR



- 1) SEAT/BACK ASSEMBLY: The seat is made up of 1.2cm. thick hot-pressed plywood, upholstered with pure leather (Black) at body contact areas and polyurethane foam. The back is made up of Dia 10mm M.S tubular frame, upholstered with pure leather (Black) at body contact areas.
 - 2) POLYURETHANE FOAM: The polyurethane foam for the seat is of density = 32 ± 2 kg/cu.m and for the back is of density = 24 ± 2 kg/cu.m.
 - 3) ARMRESTS (ADJUSTABLE): The armrest top is soft touch upholstered with pure leather mounted on to an injection moulded height adjustable type armrest.
 - 4) SYNCHRO MECHANISM: The mechanism is designed with the following features: 360 degree revolving type. Single point control. Tilt tension adjustment. 5-position locking with anti-shock feature
 - 5) CONNECTING SPINE BRACKET: Spine bracket is made of M.S. plate connecting the back with mechanism.
 - 6) PNEUMATIC HEIGHT ADJUSTMENT: The pneumatic height adjustment has an adjustment stroke of 8.5 ± 0.5 cm.
 - 7) PEDESTAL ASSEMBLY: Pedestal is made of High Pressure Die-cast Aluminum fitted with 5 nos. twinwheel nylon castors (castor wheel diameter 5.0 cm). The pedestal is of 65.0cm Pitch Center Diameter and with castors the outer dimension is 75.0 cm.
- 113-121 HEIGHT (H), 75DEPTH 75(D), WIDTH (W) 42.5 - 50.5, SEAT HEIGHT (SH).

Item Sl. No. 14
EXECUTIVE TABLE



ELEMENTS	SPECIFICATIONS
Desk	Made from 25mm MDF and clad with laminate and coated with pigmented polyurethane and SS Leg pipe
Pedestal	Desk = Mobile pedestal with box drawers moulded on roller slides and filing drawer mounted on telescopic ball slide. Pedestal contains 3 box drawers mounted as roller slides.

DIMENSIONS

	W	D	H
Desk	1800	900	750
Mobile Pedestal	400	560	560

Item Sl. No. 15
LAB MODULAR TABLE WITH SINK



The Welded storage in three configurations:

Counter having Granite top and Support Brackets for the purpose of supporting the carrying the service lines.

- 1) Storage unit with one/two shutters and one adjustable shelf
- 2) Storage unit with one drawer, one/ two shutters and one adjustable shelf

3) Storage unit with 4 drawers.

All the cabinets will have shutter and drawer fronts in CRCA steel with epoxy powder coating. All storages are without locks and can be provided if required and when specified.

Size:

Standard Storage Units of sizes:

In width: 300, 450, 600, 750, 900mm

End sink Unit: 1400mm. the unit should to be connected to the main drain

Height: 724(For 750), 874mm (900mm working ht)

Depth: 550mm

Construction:

- Framed, welded construction for durability & strength.
- Shutters and drawer fronts flush with the cabinet.

Material:

The cabinet and steel shutters are made up of 0.8 mm thick CRCA M.S. sheet.

Surface Treatment:

The complete M.S. material of cabinet is pretreated (degreased, Zinc Phosphated) and epoxy powder coated for better corrosion resistance. The thickness of powder coat is 45 -50microns, which passes the test of Salt Spray for 1000 Hours and having the Scratch Hardness of 3 Kgs.

Other Specifications:

The each storage unit is assembled with M6 Fasteners having Zinc-Cobalt coating for better corrosion resistance. The two adjacent units are connected together with Zinc-Cobalt coated Cabinet Connectors. The shutters are fitted with Nickel-chrome plated self closing hinges which are further coated with cathodic electro-deposition (CED) paint to improve the resistance to corrosion. The drawer trays are mounted on Delryn roller bearing slides, which are made up of 1.6 mm thick M.S. sheet and epoxy powder coated. A pair of slide can carry a UDL of 15 Kgs.

Shutters and Drawer fronts:

Shutters:

- Two piece shutter construction with sound deadening material for quite operation and rigidity.
- Rubber grommet on shutters for silent banging of shutter against body.
- The shutters are fitted with Nickel-chrome plated self-closing hinges which are further coated by Cathode Electro-deposition (CED) process to improve the corrosion resistance.

Drawers:

- Drawers are mounted with precision double extension (for full access) ball slides for smooth movement of drawers. Built-in anti rebound mechanism prevents drawer from coming out once it is pushed inside the cabinet. These slides are tested as per SEFA and BIFMA standards.
- One piece drawer tray construction for easy cleaning.
- Two piece drawer front construction with sound deadening material for quite operation and rigidity.

Shelf:

- Full width shelf for maximum storage space.
- Adjustable shelf at pitch of 1°
- Zn plated rigid shelf supports.

Load Carrying Capacity:

The overall load carrying capacity of cabinet is 80 Kg of UDL (40 kgs. on each shelf and 40 kgs. on bottom). The overall load carrying capacity of drawer is 15 kgs. of UDL for a pair of roller slide.

Item Sl. No. 16
LAB STOOL WITH BACK REST



1) SEAT ASSEMBLY: The seat is made up of 1.2 cm thick Commercial Grade plywood with moulded Polyurethane foam and are upholstered with replaceable fabric covers. The upholstery is available in Leather cloth and Fabric.

SEAT SIZE: Diameter 40.0 cm

ADJUSTMENTS: 360 Degree Revolving type

2) BACK ASSEMBLY : The back foam is designed with contoured Lumbar support for extra comfort. The upholstery is available in Leather cloth and Fabric.

BACK SIZE: 45.0 cm (W) covered with U foam.

3) POLYURETHANE FOAM: The polyurethane foam is moulded with density = 45 +/-2 kg/m³ and Hardness 20 +/- 2 on Hampden machine at 25% compression.

4) HEIGHT ADJUSTMENT: The manual height adjustment is very easy to operate with a help of a knob. It can be easily locked at the most comfortable position.

5) PEDESTAL ASSEMBLY : The five-prong pedestal is fabricated from 0.2cm. Thick CR steel, powder coated and fitted with an injection moulded black Polypropylene Hub Cap and 5 nos. twin wheel castors (Castor wheel diameter 5.0cm.). The pedestal is 55.0cm pitch-circle diameter (65.0 cm with Castors).

6) TWIN WHEEL CASTORS: The twin wheel castors are injection moulded in Black Nylon.

Item Sl. No. 17
LECTURE HALL STUDENT CHAIR



1) SEAT/BACK ASSEMBLY: The seat and back are made up of 1.2 cm thick hot pressed plywood, upholstered with fabric and moulded Polyurethane foam with PVC lipping all around. The back foam is designed with contoured lumbar support for extra comfort.

Back Size : 49.0cm. (W) X 47.0cm. (H)

SEAT SIZE: 49.0cm. (W) X 44.0cm. (D)

2) POLYURETHANE FOAM: The polyurethane foam is moulded with density = 45 +/-2 kg/m³ and Hardness = 20 +/- 2 on Hampden machine at 25% compression.

3) TUBULAR FRAME: The tubular frame is cantilever type & made of Dia.2.54cm. (1") x 14 BG M.S. E.R.W. tube and black powder coated. The Armrest Tube of Dia.2.54cm. (1") x 14 BG M.S. E.R.W. tube is welded to mainframe. The desklet is fitted on the right hand side.

4) DESKLET ASSEMBLY: The wooden desklet is made of 1.8cm. thk. pre-laminated chipboard with 2mm. thk. P.V.C lipping all around. SIZE: 54.0cm. (W) X 29.0cm. (D).

5) ARMRESTS: The armrests are made from chemically treated & seasoned wood with black melamine polish.

6) PAPER TRAY: The paper tray is made of 0.2cm. dia. M.S. wire spot welded to form a mesh. It is black powder coated. SIZE: 34.5cm. (W) X 35.0cm. (D).

Item Sl. No. 18
MODULAR WORK STATIONS

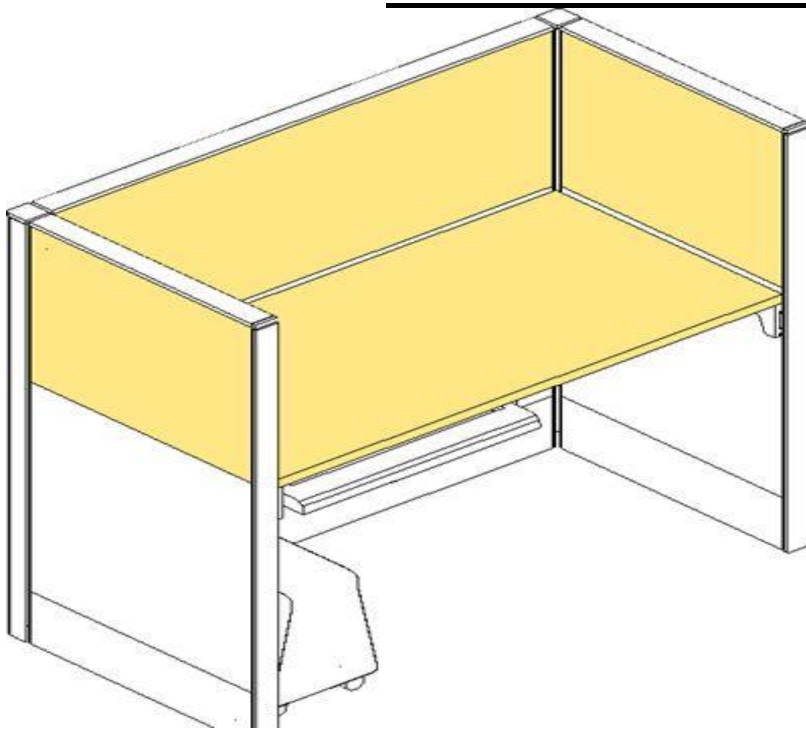

70 mm Tile Based System Tile based system

Main Frame

The system a combination of frames varying in heights from 2.5 feet to 6.5 feet and widths varying from 1.0 foot to 4 feet. The frame comprises of 2 vertical uprights, a top horizontal tube and a bottom C channel as a welded structure. The vertical upright is made from 1.5mm thick CRCA M.S. Grade D formed into “C” channel of 41.5 X 50. The top horizontal is a 1.2 mm thick M.S. tube of 38.1 X 25.4 mm (1 X 1 ½ inch). The bottom horizontal is a 1.5 mm thick M.S. ‘C’ channel of size 38.1mm x 31.8 mm. The frame will be powder coated in approved color. The pitch for mounting the brackets on the upright is 25.4 mm. The rectangular slot for wires on the upright is 60mm (H) x 18 mm (W), 1 no. at the bottom and 2 nos. at the intermediate level wherein each slot can allow 9 power cables of Dia.10 or 32 data cables □of Dia. 6. The bottom horizontal would also have 2 slots for carrying wires, which are of the size 100mm (L) X 20mm(W), wherein each slot can allow 20 power cables of Dia10 or 64 data cables of Dia.6 which is same as GRID. The Table should have 15 Amps 5Pin plug 4Nos in each table and supplier has to connect from main supply or from the other W.S.

The frames can be joined to each other to form different layouts.

Note: Please quote the unit rate of work station.

Item Sl. No. 19
OPEN STORAGE RACK



Span: 1200 mm – 2500 Width

Depth: 450 mm – 1200 mm

Heights: 1500 mm – 3000 mm

Construction : CRC with powder coated paint.

Racks should be adjustable and stackable and side to mountable and conform to storage area.

Load bearing capacity of each rack should be more than 300Kg.

Item Sl. No. 20
SOFA SINGLE SEATER



1 Seater: Total Length 975, Total Width 885, c Total Height 810 w/o Legs, Seating Area Width 520, Seating Area Length 520, Seating Area Height from Ground 350 add leg height, Arm Height 470 add leg height, Arm Length 550 Back Height from Arm 340 j Back Width 365, arm Width 225 l Leg Height 125, Length between Legs 1750 -1220- 750 n Width between Legs 510. Made of 800 GLM PVC top coat 200, middle coat 500, fabric polyester knitted,Sautex fabric. FRAME MATERIAL (TROPICAL WOOD / PINE WOOD/ RUBBER WOOD): pine wood MOISTURE CONTENT : less

than 8%. Seat foam block foam in multiple of 24 mm.thickness 28- 30 kg./m³. BACK FOAM: block foam in multiple of 24mm thickness.Leg Material Mild Steel, Chrome plated 125 mm.

Item Sl. No. 21
SOFA 3 SEATER



1) **CONNECTING BEAM ASSEMBLY:** It is a fabricated assembly made by welding MS. square pipe 6.0 cm. x 6.0 cm. x 10 BG. thick. to 0.5cm. thick HR. Steel plate on each side for fixing the moulded side frame assembly. The connecting beam assembly is black powder coated.

2) **SEATREST ASSEMBLY:** The seat rest assembly consists of a fabricated inner-frame assembly insitu-moulded with Polyurethane foam having density = 45 +/- 2 Kg./cm³. The hardness of the P.U. foam = 23 - 27 Kgs. on Hampden m/c. for 25% compression of the foam. The complete moulded seat rest assembly is covered with a replaceable fabric upholstery cover.

Over all Size : 190cm W x 74D x 78H

SEAT SIZE: 52.0cm. (W) X 50.0cm. (D) X 6.0cm. (T) Approx.

3) **BACKREST ASSEMBLY:** The backrest assembly is flexing type and consists of a fabricated inner-frame assembly insitu-moulded with Polyurethane foam having density = 45 +/- 2 Kg./cm³. The hardness of the P.U. foam = 16 – 20 Kgs. on Hampden m/c. for 25% compression of the foam. The complete moulded backrest assembly is covered with a replaceable fabric upholstery cover.

BACK SIZE: 52.0cm. (W) X 57.0cm. (H) X 12.0cm. (T) Approx.

4) **SIDEFAME (ARMREST) ASSEMBLY:** The side frame assembly, which forms the armrest assembly, is fitted to the two ends of the connecting beam assly. to form the leg-cum-armrest assembly It consists of a fabricated inner-frame assembly insitu-moulded with Polyurethane foam having density = 45 +/-2 Kg./cm³. The hardness of the P.U. foam = 16 - 20 Kgs. on Hampden m/c. for 25% compression of the foam. The complete moulded side frame assembly is covered with a replaceable fabric upholstery cover.

SIDEFAME (ARMREST) SIZE: 63.0cm. (D) X 58.0cm. (H) X 12.0cm. (T) Approx.

6) **ADJUSTABLE GLIDE:** The adjustable glide is injection moulded in black ABS and is used for level adjustment of the sofa on uneven floor surface. It is fitted to the side frame assembly.

Item Sl. No. 22
STAFF CHAIR



1. SEAT/BACK ASSEMBLY: The seat is made of moulded Polyurethane foam and 12mm thk Recycled composite board upholstered with replaceable fabric cover. The back is made of MS tubular frame insitu moulded with Polyurethane foam and upholstered with fabric cover. Back Size 45.0 cm. (W) x 47.0 cm. (H) Seat Size: 45.0 cm. (W) x 50.5 cm. (D)
2. POLYURETHANE FOAM: The Polyurethane foam is moulded with density = 45 ± 2 kg/m³ and Hardness for back foam is 16 (+0/-2) & that for seat foam is 20 (+/-2) at 25% compression.
- 3.ARMRESTS :Armrest has a two piece construction and is mounted on to the tubular frame structure.It is injection moulded in talc filled PP.
8. TUBULAR FRAME STRUCTURE: The powder coated tubular frame structure is made of 48 mm x 18.5 mm x 2.5 mm thk M.S. ERW oblong tube.

Item Sl. No. 23
STORAGE CUPBOARD WITH LOCK



- 18 gauge steel wardrobe with lock & key
made of 1.25 mm CRCA (Cold Rolled Close Annealed) Steel powder coated
4 adjustable shelves
"Width: 900 , Depth: 500 , Height: 2000 approx"

Item Sl. No. 24
VISITOR CHAIR



- 1) SEAT/BACK ASSEMBLY: The seat is made up of 1.2cm. thick hot-pressed plywood, upholstered with pure leather (Black) at body contact areas and polyurethane foam. The back is made up of Dia 10mm M.S tubular frame, upholstered with pure leather (Black) at body contact areas.
 - 2) POLYURETHANE FOAM: The polyurethane foam for the seat is of density = 32 ± 2 kg/cu.m and for the back is of density = 24 ± 2 kg/cu.m.
 - 3) ARMRESTS (ADJUSTABLE): The armrest top is soft touch upholstered with pure leather mounted on to an injection moulded height adjustable type armrest.
 - 4) LEG FRAME ASSEMBLY (9N12AX): Leg frame welded assembly is made from 38mm X 19mm X 1.2mm elliptical MS ERW tube with base plate for seat fixing.
- 95.5HEIGHT (H), 75 DEPTH (D), 75WIDTH (W), 44 SEAT HEIGHT (SH).

Section – VIII**Quality Control Requirements**

(Proforma for equipment and quality control employed by the manufacturer(s))

Tender Reference No.

Date of opening

Time

Name and address of the Tenderer:

Note: All the following details shall relate to the manufacturer(s) for the goods quoted for.

- 01 Name of the manufacturer
 - a. full postal address
 - b. full address of the premises
 - c. telegraphic address
 - d. telex number
 - e. telephone number
 - f. fax number

- 02 Plant and machinery details
- 03 Manufacturing process details
- 04 Monthly (single shift) production capacity of goods quoted for
 - a. normal
 - b. maximum

- 05 Total annual turn-over (value in Rupees)
- 06 Quality control arrangement details
 - a. for incoming materials and bought-out components
 - b. for process control
 - c. for final product evaluation
- 07 Test certificate held
 - a. . type test
 - b. . BIS/ISO certification
 - c. . any other
- 08 Details of staff
 - a. technical
 - b. skilled
 - c. unskilled

Signature and seal of the Tenderer

Section – IX Qualification Criteria

1. The Tenderer must be a Manufacturer or its Authorized Agent/ Distributor/ Dealer/ Stockist (hereinafter called only Authorised Agent).
2. The manufacturer should have an average annual turnover of **Rs. *as computed*** [*Please refer Column (e) of the tabular statement and the note given in table 1 below*] during the last three years (2010-11, 2011-12, 2012-13). The manufacturer should submit balance sheet and Profit & loss account duly attested by chartered accountant for the preceeding three financial years.
3. The tenderer quoting as authorised agents must submit the manufacturer's authorisation as per the format given in Section XIV. The agent should have been appointed at least one year prior to the publication of this tender enquiry. The proof of appointment as authorised agent shall be submitted (if not original then notarized photocopy, however purchaser may call for original to varify)
4. Meeting the criteria as per clause 2 & 3 above, the tenderer quoting as Authorised Agent should have an average annual turnover of not less than Rupees **Rs. *as computed*** [*Please refer Column (f) of the tabular statement and the note given in table 1 below*] in the last 3 financial year. They shall submit balance sheet and profit & loss account of the manufacturer and also their own for preceeding three financial year duly attested by chartered accountant.
5. The tenderer should have satisfactorily completed contract(s) of similar nature i.e furniture items in his own name at least one contract with a minimum value of **Rs. *as computed*** [*Please refer Column (h) of the tabular statement and the note given in table 1 below*] or two contracts with minimum value of **Rs. *as computed*** [*Please refer Column (i) of the tabular statement and the note given in table 1 below*] or three contracts with minimum value of **Rs. *as computed*** [*Please refer Column (j) of the tabular statement and the note given in table 1 below*] each during the last 03 years prior to the submission of bid.
6. Solvency Certificate
The bidder shall submit solvency certificate equal to **Rs. *as computed*** [*Please refer Column (g) of the tabular statement and the note given in table 1 below*] issued in the name of the bidder
7. The bidder should have earned a net profit at least in two financial years out of the preceding three financial years.
8. Technical Requirement
The manufacturer itself or on whose behalf the bid is submitted should have the certification for ISO 9001/14001 certification. The self-attested copy of the certificate(s) to be attached.

Note:

Notwithstanding anything stated above, the Purchaser reserves the right to assess the Tenderer's capability and capacity to perform the contract satisfactorily before deciding on award of Contract, should circumstances warrant such an assessment in the overall interest of the Purchaser. The Purchaser reserves the right to ask for a free demonstration of the quoted Goods/Stores at a pre determined place acceptable to the purchaser for technical acceptability as per the tender specifications, before the opening of the Price Tender.

Table-1

Sl. No	Name of the Item	Qty	EMD (in INR)	Min. Av. Annual Turnover of Manufacturer (in INR)	Min. Av. Turnover of Authorised Agent (in INR)	Min. Solvency (in INR)	Min. value of One order (in INR)	Min. value of Two orders each (in INR)	Min. value of Three orders each (in INR)
(a)	(b)	(c)	(d)	(e)	(f)	(g)	(h)	(i)	(j)
1	EXAMINATION COUCH	6	3000	150000	75000	60000	120000	75000	60000
2	TREATMENT COUCH	6	2400	120000	60000	48000	96000	60000	48000
3	FOWLER BED	50	50000	2500000	1250000	1000000	2000000	1250000	1000000
4	WHEEL CHAIR	4	1500	72000	36000	28800	57600	36000	28800
5	ARMLESS CHAIR	76	6100	304000	152000	121600	243200	152000	121600
6	BED SIDE CABINET	51	3100	153000	76500	61200	122400	76500	61200
7	CAFETARIA CHAIR	48	2400	12000	60000	48000	96000	60000	48000
8	CAFETARIA TABLE (1.2M x 1.2M)	8	3200	160000	80000	64000	128000	80000	64000
9	CONFERENCE CHAIR	34	6800	340000	170000	136000	272000	170000	136000
10	CONFERENCE TABLE 24 SEATER	1	2500	125000	62500	50000	100000	62500	50000
11	COT WITH MATTRESS - SINGLE	6	2900	144000	72000	57600	115200	72000	57600
12	DOUBLE SIDED BOOK RACK	5	2500	125000	62500	50000	100000	62500	50000
13	EXECUTIVE CHAIR	28	5600	280000	140000	112000	224000	140000	112000
14	EXECUTIVE TABLE	35	10500	525000	262500	210000	420000	262500	210000
15	LAB MODULAR TABLE WITH SINK	4	10000	500000	250000	200000	400000	250000	200000
16	LAB STOOL WITH BACK REST	50	3000	150000	75000	60000	120000	75000	60000
17	LECTURE HALL STUDENT CHAIR	25	2000	100000	50000	40000	80000	50000	40000
18	MODULAR WORK STATIONS	8	4000	200000	100000	80000	160000	100000	80000
19	OPEN STORAGE RACK	50	15000	750000	375000	300000	600000	375000	300000
20	SOFA SINGLE SEATER	10	2000	100000	50000	40000	80000	50000	40000
21	SOFA 3 SEATER	4	2000	100000	50000	40000	80000	50000	40000

Sl. No	Name of the Item	Qty	EMD (in INR)	Min. Av. Annual Turnover of Manufacturer (in INR)	Min. Av. Turnover of Authorised Agent (in INR)	Min. Solvency (in INR)	Min. value of One order (in INR)	Min. value of Two orders each (in INR)	Min. value of Three orders each (in INR)
22	STAFF CHAIR	57	6900	342000	171000	136800	273600	171000	136800
23	STORAGE CUPBOARD WITH LOCK	33	9900	495000	247500	198000	396000	247500	198000
24	VISITOR CHAIR	50	4500	225000	112500	90000	180000	112500	90000
	Total for all items			7972000	4040000	3232000	6464000	4040000	3232000

Note:

- 1) Bidder may quote one or more items but bidder cannot bid for part quantity of same item.
- 2) If the bidder quotes for one item, the bidder is required to meet the requirement of EMD, Average Annual Turn Over (for the manufacturer and Agent as the case may be), Solvency certificate, satisfactory work execution as mentioned against the item for which the bid is submitted
- 3) In case the bidder quotes for more than one item, the bidder would be required to meet cumulative requirement of EMD, Average Annual Turnover, Solvency certificate, Satisfactory work execution) for all the items for which the bid is submitted.

Example: (for sl. no.2 & 3 above):

- If the bid is submitted for one item (say item at sl. no. 8) then the bidder is required to meet the followings:
EMD : Rs. 52,400
Minimum Average Annual Turn Over for last three years (Manufacturer) : Rs. 26,20,000
Minimum Average Annual Turn Over for last three years (Authorized Agent) : Rs. 13,10,000
Minimum Value of Solvency Certificate : Rs. 10,48,000
Minimum value of order successfully executed (if, one order) : Rs.20,96,000 Each
Minimum value of each order successfully executed (if, two orders) :13,10,000 Rs each
Minimum value of each order successfully executed (if, three orders) : Rs.10,48,000 each
- If the bid is submitted for more than one item (say three items: Items at sl. no. 1,2 & 3) then the bidder is required to meet the followings:
EMD : Rs. 55,400
Minimum Average Annual Turn Over for last three years (Manufacturer) : Rs. 27,70,000
Minimum Average Annual Turn Over for last three years (Authorized Agent) : Rs. 13,85,000
Minimum Value of Solvency Certificate : Rs. 11,08,000
Minimum Order value of order executed (if, one order) : Rs. 22,16,000
Minimum Order value of each order executed (if, two orders) : Rs.13,85,000
Minimum Order value of each order executed (if, three orders) : Rs. 11,08,000
- Likewise the bidder has to calculate the requirement to be met depending upon the no. of items for which bid is submitted.

PROFORMA 'A'**PROFORMA FOR PERFORMANCE STATEMENT
(or the period of last 3 years)**

Sl. No.	Client's Name and Address	Description of the goods ordered	Agreement/ Notification of Award No. with date	Contract Value (Rs. in Cr.)	Date of Completion		Reasons for delay in completion if any	Ref. of document (with page no.) in support of meeting Qualification Criteria.
					As per NOA/ Agreement	Actual		

SEAL AND SIGNATURE OF THE BIDDER

Note:

1. In support of having completed above supplies attach notarized purchase orders/work order copies and notarized copies of the satisfactory completion certificate from the consignee(s) .If at any time, information furnished is proved to be false or incorrect, the earnest money furnished will be forfeited.
2. JV/Consortium not allowed. However exemption is given to NSIC as per prevailing Government rules. Foreign firms not allowed.
3. The turnover and experience should be in the name of bidding company and not in the name of subsidiary/associate company/group company etc.

Section – X

TENDER FORM

Date_____

To

Head (P&CD), HLL Lifecare Limited, Procurement and Consultancy Division, B-14 A, Sector -62, Noida -201307, Uttar Pradesh

Ref. Your TE document No. _____ dated _____

We, the undersigned have examined the above mentioned TE document, including amendment/corrigendum No. _____, dated _____ (*if any*), the receipt of which is hereby confirmed. We now offer to supply and deliver_____ (*Description of goods and services*) in conformity with your above referred document for the sum of amount as mentioned in price bid, attached herewith and made part of this tender.

If our tender is accepted, we undertake to supply the goods and perform the services as mentioned above, in accordance with the delivery schedule specified in the List of Requirements.

We further confirm that, if our tender is accepted, we shall provide you with a performance security of required amount in an acceptable form in terms of GCC clause 5, read with modification, if any, in Section - V – “Special Conditions of Contract”, for due performance of the contract.

We agree to keep our tender valid for acceptance as required in the GIT clause 20, read with modification, if any in Section - III – “Special Instructions to Tenderers” or for subsequently extended period, if any, agreed to by us. We also accordingly confirm to abide by this tender up to the aforesaid period and this tender may be accepted any time before the expiry of the aforesaid period. We further confirm that, until a formal contract is executed, this tender read with your written acceptance thereof within the aforesaid period shall constitute a binding contract between us.

We further understand that you are not bound to accept the lowest or any tender you may receive against your above-referred tender enquiry.

We confirm that we do not stand deregistered/banned/blacklisted by any Govt. Authorities.

We confirm that we fully agree to the terms and conditions specified in above mentioned TE document, including amendment/ corrigendum if any

(Signature with date)

(Name and designation) Duly authorised to sign tender for and on behalf of

SECTION – XI PRICE SCHEDULE**PRICE SCHEDULE FOR DOMESTIC GOODS OR GOODS OF FOREIGN ORIGIN LOCATED WITHIN INDIA**

1	2	3	4	5						6	
				Price per unit (Rs.)							
Item sl. no.	Brief Description of Goods	Country of Origin	Quantity (Nos.)	Ex - factory/ Ex -warehouse /Ex-showroom /Off - the shelf (a)	Packing and Forwarding charges (b)	Excise Duty (if any) [%age & value] (c)	Sales Tax/ VAT(if any) [%age & value] (d)	Inland Transportation, Insurance for a period including 3 months beyond date of delivery, loading/ unloading and Incidental costs till consignee's site (e)	Incidental Services at the Consignee's site (f)	Unit Price (at Consignee Site) basis (g) =a+b+c+d+e+f	Total Price (at Consignee Site) basis (Rs.) 4 x 5(g)
1.											
2.											
3.											

Total Tender price in Rupees: _____

In words: _____

Note: -

If there is a discrepancy between the unit price and total price THE UNIT PRICE shall prevail.

Name _____

Business Address _____

Place: _____

Signature of Tenderer _____

Date: _____

Seal of the Tenderer _____

SECTION – XII QUESTIONNAIRE

Fill up the Section XX – Check List for Tenderers and enclose with the Tender

1. The tenderer should furnish specific answers to all the questions/issues mentioned in the Checklist. In case a question/issue does not apply to a tenderer, the same should be answered with the remark “not applicable”.
2. Wherever necessary and applicable, the tenderer shall enclose certified copy as documentary proof/ evidence to substantiate the corresponding statement.
3. In case a tenderer furnishes a wrong or evasive answer against any of the question/issues mentioned in the Checklist, its tender will be liable to be ignored.

SECTION – XIII
BANK GUARANTEE FORM FOR EMD

Whereas _____ (hereinafter called the “Tenderer”) has submitted its quotation dated _____ for the supply of _____ (hereinafter called the “tender”) against the purchaser’s tender enquiry No. _____ Know all persons by these presents that we _____ of _____ (Hereinafter called the “Bank”) having our registered office at _____ are bound unto _____ (hereinafter called the “Purchaser) in the sum of _____ for which payment will and truly to be made to the said Purchaser, the Bank binds itself, its successors and assigns by these presents. Sealed with the Common Seal of the said Bank this _____ day of _____ 20____. The conditions of this obligation are:

- (1) If the Tenderer withdraws or amends, impairs or derogates from the tender in any respect within the period of validity of this tender.
- (2) If the Tenderer having been notified of the acceptance of his tender by the Purchaser during the period of its validity:-
 - a) fails or refuses to furnish the performance security for the due performance of the contract.
 - or
 - b) fails or refuses to accept/execute the contract.
 - or
 - c) if it comes to notice that the information/documents furnished in its tender is incorrect, false, misleading or forged

We undertake to pay the Purchaser up to the above amount upon receipt of its first written demand, without the Purchaser having to substantiate its demand, provided that in its demand the Purchaser will note that the amount claimed by it is due to it owing to the occurrence of one or both the two conditions, specifying the occurred condition(s).

This guarantee will remain in force for a period of forty-five days after the period of tender validity and any demand in respect thereof should reach the Bank not later than the above date.

(Signature of the authorised officer of the Bank)

Name and designation of the officer

Seal, name & address of the Bank and address of the Branch

SECTION – XIV

MANUFACTURER'S AUTHORISATION FORM

To

Head (P&CD), HLL Lifecare Limited, Procurement and Consultancy Division, B-14 A, Sector -62, Noida -201307, Uttar Pradesh

Dear Sirs,

Ref. Your TE document No _____, dated _____

We, _____ who are proven and reputable manufacturers of _____ (*name and description of the goods offered in the tender*) having factories at _____, hereby authorise Messrs _____ (*name and address of the agent*) to submit a tender, process the same further and enter into a contract with you against your requirement as contained in the above referred TE documents for the above goods manufactured by us.

We further confirm that no supplier or firm or individual other than Messrs. _____ (*name and address of the above agent*) is authorised to submit a tender, process the same further and enter into a contract with you against your requirement as contained in the above referred TE documents for the above goods manufactured by us.

We also hereby extend our full warranty, CMC as applicable as per clause 15 of the General Conditions of Contract, read with modification, if any, in the Special Conditions of Contract for the goods and services offered for supply by the above firm against this TE document.

Yours faithfully,

[Signature with date, name and designation]

for and on behalf of Messrs _____

[Name & address of the manufacturers]

Note: 1. This letter of authorisation should be on the letter head of the manufacturing firm and should be signed by a person competent and having the power of attorney to legally bind the manufacturer.

2. Original letter may be sent.

SECTION – XV

BANK GUARANTEE FORM FOR PERFORMANCE SECURITY

To
**Head (P&CD), HLL Lifecare Limited, Procurement and Consultancy Division, B-14 A,
Sector -62, Noida -201307**

WHEREAS _____ (Name and address of the supplier) (Hereinafter called “the supplier”) has undertaken, in pursuance of contract no _____ dated _____ to supply (description of goods and services) (herein after called “the contract”).

AND WHEREAS it has been stipulated by you in the said contract that the supplier shall furnish you with a bank guarantee by a scheduled commercial bank recognised by you for the sum specified therein as security for compliance with its obligations in accordance with the contract;

AND WHEREAS we have agreed to give the supplier such a bank guarantee;

NOW THEREFORE we hereby affirm that we are guarantors and responsible to you, on behalf of the supplier, up to a total of. _____ (Amount of the guarantee in words and figures), and we undertake to pay you, upon your first written demand declaring the supplier to be in default under the contract and without cavil or argument, any sum or sums within the limits of (amount of guarantee) as aforesaid, without your needing to prove or to show grounds or reasons for your demand or the sum specified therein.

We hereby waive the necessity of your demanding the said debt from the supplier before presenting us with the demand.

We further agree that no change or addition to or other modification of the terms of the contract to be performed there under or of any of the contract documents which may be made between you and the supplier shall in any way release us from any liability under this guarantee and we hereby waive notice of any such change, addition or modification.

This guarantee shall be valid up to 30 (thirty) months from the date of Notification of Award i.e. up to ----- (indicate date)

.....
(Signature with date of the authorised officer of the Bank)

.....
Name and designation of the officer

.....
Seal, name & address of the Bank and address of the Branch

SECTION – XVI**CONTRACT FORM****CONTRACT FORM FOR SUPPLY, INSTALLATION, COMMISSIONING, HANDING OVER, TRIAL RUN, TRAINING OF OPERATORS & WARRANTY OF GOODS**

(Address of the Purchaser's/Consignee's office issuing the contract)

Contract No. _____ dated _____

This is in continuation to this office's Notification of Award No. _____ dated _____

1. Name & address of the Supplier: _____
2. Purchaser's TE document No. _____ dated _____ and subsequent Amendment No. _____, dated _____ (if any), issued by the purchaser
3. Supplier's Tender No. _____ dated _____ and subsequent communication(s) No. _____ dated _____ (if any), exchanged between the supplier and the purchaser in connection with this tender.
4. In addition to this Contract Form, the following documents etc, which are included in the documents mentioned under paragraphs 2 and 3 above, shall also be deemed to form and be read and construed as integral part of this contract:

- (i) General Conditions of Contract;
- (ii) Special Conditions of Contract;
- (iii) List of Requirements;
- (iv) Technical Specifications;
- (v) Quality Control Requirements;
- (vi) Tender Form furnished by the supplier;
- (vii) Price Schedule(s) furnished by the supplier in its tender;
- (viii) Manufacturers' Authorisation Form (if applicable for this tender);
- (ix) Purchaser's Notification of Award

Note: The words and expressions used in this contract shall have the same meanings as are respectively assigned to them in the conditions of contract referred to above. Further, the definitions and abbreviations incorporated under clause 1 of Section II – 'General Instructions to Tenderers' of the Purchaser's TE document shall also apply to this contract.

5. Some terms, conditions, stipulations etc. out of the above-referred documents are reproduced below for ready reference:
 - (i) Brief particulars of the goods and services which shall be supplied/ provided by the supplier are as under:

Schedule No.	Brief description of goods/services	Accounting unit	Quantity to be supplied	Unit Price	Total price	Terms of delivery

Any other additional services (if applicable) and cost thereof: _____

Total value (in figure) _____ (In words) _____

- 2. Delivery schedule
- (iii) Details of Performance Security
- (iv) Quality Control
 - (a) Mode(s), stage(s) and place(s) of conducting inspections and tests.
 - (b) Designation and address of purchaser's inspecting officer
- (v) Destination and despatch instructions
- (vi) Consignee, including port consignee, if any
 - 3. Warranty clause
 - 4. Payment terms
 - 5. Paying authority

**(Signature, name and address
of the Purchaser's/Consignee's authorised official)**
For and on behalf of _____

Received and accepted this contract

(Signature, name and address of the supplier's executive
duly authorised to sign on behalf of the supplier)

For and on behalf of _____

(Name and address of the supplier)

(Seal of the supplier)

Date: _____

Place: _____

SECTION – XVII

CONSIGNEE RECEIPT CERTIFICATE
(To be given by consignee’s authorized representative)

The following store (s) has/have been received in good condition:

- 1) Contract No. & date : _____
- 2) Supplier’s Name : _____
- 3) Consignee’s Name & Address with
telephone No. & Fax No. : _____
- 4) Name of the item supplied : _____
- 5) Quantity Supplied : _____
- 6) Date of Receipt by the Consignee : _____
- 7) Name and designation of
Authorized Representative of
Consignee : _____
- 8) Signature of Authorized
Representative of Consignee with
date : _____
- 9) Seal of the Consignee : _____

SECTION – XVIII

Proforma of Final Acceptance Certificate by the Consignee

No _____

Date _____

To

M/s _____

Subject: Certificate of commissioning of equipment/plant.

This is to certify that the Goods/Storesas detailed below has/have been received in good conditions along with all the standard and special accessories and in accordance with the contract/ specifications. The same has beenaccepted and taken in stock.

(a) Contract No _____ dated _____

(b) Description of the equipment(s)/plants: _____

(c) Quantity: _____

(d) Receipt/ Goods Consignment Note no _____ dated _____

(e) Name of the Transporters: _____

(f) Name of the Consignee: _____

(g) Date of acceptance: _____

(h) Remarks if any: _____

Signature

Name

Designation with Stamp/Seal

SECTION – XIX

This section is deleted

SECTION – XX**CHECKLIST****Name of Tenderer:****Name of Manufacturer:**

Sl No.	Activity	Yes/ No/ NA	Page No. in the TE document	Remarks
1. a.	Have you enclosed EMD of required amount for the quoted schedules?			
b.	In case EMD is furnished in the form of Bank Guarantee, has it been furnished as per Section XIII?			
c.	In case Bank Guarantee is furnished, have you kept its validity of 165 days from Techno Commercial Tender Opening date as per clause 19 of GIT?			
2. a.	Have you enclosed duly filled Tender Form as per format in Section X?			
b.	Have you enclosed Power of Attorney in favour of the signatory?			
3.	Are you a SSI unit, if yes have you enclosed certificate of registration issued by Directorate of Industries/NSIC			
4. a.	Have you enclosed clause-by-clause technical compliance statement for the quoted goods vis-à-vis the Technical specifications?			
b.	In case of Technical deviations in the compliance statement, have you identified and marked the deviations?			
5. a.	Have you submitted satisfactory performance certificate as per the Proforma for performance statement as per Proforma given in TE document in respect of all orders?			
b.	Have you submitted copy of the order(s) and end user certificate?			
6.	Have you submitted manufacturer's authorization as per Section XIV?			
7.	Have you submitted prices of goods, in the Price Schedule as per Section XI?			
8.	Have you kept validity of 120 days from the Techno Commercial Tender Opening date as per the TE document?			

Sl No.	Activity	Yes/ No/ NA	Page No. in the TE document	Remarks
9.	Have you furnished Income Tax Account No. as allotted by the Income Tax Department of Government of India?			
10.	Have you intimated the name and full address of your Banker (s) along with your Account Number			
11.	Have you fully accepted payment terms as per TE document?			
12.	(a) Have you fully accepted delivery period as per TE document? (b) Have you accepted terms of delivery at consignee site?			
13.	Have you submitted the certificate of incorporation?			
14.	Have you accepted the warranty as per TE document?			
15.	Have you accepted terms and conditions of TE document?			
16.	Have you furnished documents establishing your eligibility & qualification criteria as per TE documents?			
17.	Have you furnished Annual Report (Balance Sheet and Profit & Loss Account) for last three years prior to the date of Tender opening?			
18.	Have you submitted quality control requirement?			

N.B.

1. All pages of the Tender should be page numbered and indexed.
2. The Tenderer may go through the checklist and ensure that all the documents/confirmations listed above are enclosed in the tender and no column is left blank. If any column is not applicable, it may be filled up as NA.
3. It is the responsibility of tenderer to go through the TE document to ensure furnishing all required documents in addition to above, if any.

(Signature with date)

(Full name, designation & address of the person duly authorised sign on behalf of the Tenderer)
For and on behalf of

(Name, address and stamp of the tendering firm)

Section – XXI

Consignee List

**North Eastern Institute of Folk
Medicines, Pasighat,
Arunachal Pradesh**

NB: The consignee will ensure timely issue of Octroi Exemption Certificates, Road Permits & Entry Tax Exemption Certificates, wherever applicable, to the suppliers.