	HLL LIFECARE LIMITED, PEROORKADA FACTORY THIRUVANANTHAPURAM 695 005 Phn: 0471 2437270	Pages- 1 of 18
	TENDER FOR THE SUPPLY OF FLAP UNIT AND ACCESSORIES AT HLL,PEROORKADA FATORY	
PLANT : PFT	IFB NO – HLL/PFT/CED/STATIC-TESTING/FLAP UNIT/17	DATE: 27/10/2017

**TENDER FOR THE SUPPLY OF
FLAP UNIT AND ACCESSORIES
AT
HLL LIFECARE LIMITED,PEROORKADA FACTORY,
THIRUVANANTHAPURAM**

**IFB NO – HLL/PFT/CED/STATIC-TESTING/FLAP UNIT/17
27/10/2017**

	HLL LIFECARE LIMITED, PEROORKADA FACTORY THIRUVANANTHAPURAM 695 005 Phn: 0471 2437270	Pages- 2 of 19
	TENDER FOR THE SUPPLY OF FLAP UNIT AND ACCESSORIES AT HLL,PEROORKADA FATORY	
PLANT : PFT	IFB NO – HLL/PFT/CED/STATIC-TESTING/FLAP UNIT/17	DATE: 27.10.2017

**HLL LIFECARE LIMITED,
PEROORKADA FACTORY
THIRUVANANTHAPURAM 695 005**

INVITATION FOR BIDS (IFB)

IFB NO – HLL/PFT/CED/STATIC-TESTING/FLAP UNIT/17 DATED: 27/10/2017

HLL Lifecare Limited (HLL), a Government of India Enterprise is in the process of fabricating Electronic Pin hole testing machine(Dual station) for testing male Condoms. For the said project, sealed and super scribed bids are invited from competent and experienced Suppliers/Contractors who are capable to do the following work meeting the requirements as per our tender.

Sl. No	Brief Description of Item/Work	Qty
1	Supply of Flap unit & Accessories as per tender specifications and schedule at HLL Lifecare Limited, Peroorkada Factory, Thiruvananthapuram 695 005	As per Schedule IV

2. The bid documents will be available up to 15.00 Hrs. on the previous working day of the opening of the bids. The scheduled date for issue, receipt and opening of bids is as follows.

- a) Date of issue of tender document - 27/10/2017 onwards
- b) Last date and time for receipt of bids - 10/11/2017 up to 15.00 Hrs.
- c) Date and time of opening of bids - 10/11/2017, 15.30 Hrs.
- d) Address for communication, receipt and place of opening of bids:

Dy General Manager (CED),
Central Engineering Division,
HLL Lifecare Limited (A Government of India Enterprise),
PB No 2, Peroorkada, Thiruvananthapuram – 695005,
Kerala State, India
Ph: (++91 471) 2433374,2437270 –501,502
Tele Fax: (++ 91 471) 2432647
E-mail: rajeevrv@lifecarehll.com, rajeshkumar@lifecarehll.com

3. The completed and sealed bid documents should be submitted to Dy. General Manager (CED) in the above address. The outer cover should bear the Enquiry No, closing date and General description of item tendered, and the words “DO NOT OPEN BEFORE” 15.30 Hrs (IST) on 10/11/2017.

	HLL LIFECARE LIMITED, PEROORKADA FACTORY THIRUVANANTHAPURAM 695 005 Phn: 0471 2437270	Pages- 3 of 19
	TENDER FOR THE SUPPLY OF FLAP UNIT AND ACCESSORIES AT HLL,PEROORKADA FATORY	
PLANT : PFT	IFB NO – HLL/PFT/CED/STATIC-TESTING/FLAP UNIT/17	DATE: 27.10.2017

4. Bids will be opened in the presence of Bidders representative(s) who choose to attend on the specified date and time, at the office of HLL at the address given in Clause 2 (d) above.
5. In the event of the date specified for bid receipt and opening being declared as a closed holiday for the above purchaser's office, the due date for submission of bids and opening of bids will be the following working day at the appointed times.
6. HLL may, at its discretion, extend this deadline for submission of bids by amending the Bid Documents or any other reasons, in which case all rights and obligations of HLL and Bidders previously subject to the deadline will thereafter be subject to the deadline as extended.
7. HLL will not be held responsible for the postal delay, if any, in the delivery of the bidding document or the non-receipt of the same. Bids sent by Telex/Fax/Telegraph will not be accepted.
8. The company reserves the right to club or split the items of works, change the qualifying criteria at their discretion and to reject or cancel the Invitation for bids without assigning any reason thereof.
9. In addition to the invitation for bids, the bidding documents include the following schedules.

SCHEDULE	- I	: Conditions of Bid
SCHEDULE	- II	: Detailed Specification of Item
SCHEDULE	- III	: Conditions of Contract
SCHEDULE	- IV	: Format of Quoting
SCHEDULE	- V	: Acceptance Form

DY. GENERAL MANAGER (CED)

	<p align="center">HLL LIFECARE LIMITED, PEROORKADA FACTORY THIRUVANANTHAPURAM 695 005 Phn: 0471 2437270</p>	<p align="center">Pages- 4 of 19</p>
	<p align="center">TENDER FOR THE SUPPLY OF FLAP UNIT AND ACCESSORIES AT HLL,PEROORKADA FATORY</p>	
<p>PLANT : PFT</p>	<p>IFB NO – HLL/PFT/CED/STATIC-TESTING/FLAP UNIT/17</p>	<p>DATE: 27.10.2017</p>

**SCHEDULE I
CONDITIONS OF BID**

1. Definitions

- a. **“Invitation For Bid”** shall mean and include the present document, and such other complements and agenda, which may subsequently be issued in this connection.
- b. **“Purchaser/Owner”** shall mean HLL Lifecare Limited, (Peroorkada Factory) or its units thereof.
- c. **“Bidder”** shall mean the person, firm of Corporation submitting a bid against this invitation for bid and shall also include his agents and representatives.
- d. **“Supplier/Contractor”** shall mean the bidder whose bid has been accepted and shall also include his successors and assigns, agents and representatives.
- e. **“Contract”** means signed acceptance of the Letter of Intend, if issued, and order by the supplier.
- f. **“Site”** shall mean **HLL Lifecare Limited, Peroorkada Factory, Thiruvananthapuram – 695 005.**

2. Bid Information and Period of Validity

2.1 The Bid must include the following information,

- a. Enquiry / IFB No.
- b. Promised Delivery Schedule for each item/work.
- c. Certificate that bid is in total conformity with the specifications and terms and conditions mentioned in the bid document and if not, list of exclusions, and/or exceptions.
- d. All information requested in the specifications, dimensional drawings, technical literature describing the make offered, material etc., as specified in the bid document.
- e. The Price should be quoted as per the following:
 - i) The Bidder shall indicate all prices including basic price, the relevant duties and taxes, other levies, packing & forwarding charges, charges for inland transportation and other local costs incidental to delivery of the goods to supplier's site, etc. on the appropriate price schedule (FORMAT FOR QUOTING – SCHEDULE IV) attached to these documents for completing the above work as per the Specification, Terms and Conditions as specified in the Bid Documents. Civil work is excluded from the scope of the supplier.
 - ii) Bidder must quote for unit price and total price based on the requirement shown in the bid document.
 - iii) Price should be firm without any escalation on any account until the order is completely fulfilled.
 - iv) All other documents/certificate/information as specified in the bid document.

	<p align="center">HLL LIFECARE LIMITED, PEROORKADA FACTORY THIRUVANANTHAPURAM 695 005 Phn: 0471 2437270</p>	<p align="center">Pages- 5 of 19</p>
	<p align="center">TENDER FOR THE SUPPLY OF FLAP UNIT AND ACCESSORIES AT HLL,PEROORKADA FATORY</p>	
<p>PLANT : PFT</p>	<p>IFB NO – HLL/PFT/CED/STATIC-TESTING/FLAP UNIT/17</p>	<p>DATE: 27.10.2017</p>

2.2 Bids shall remain valid for **90 days** after the date of bid opening prescribed by the Purchaser.

3. Format and Signing of Bid

- 3.1 All pages of the bid, except for un-amended printed literature shall be signed by the person or persons signing the bid.
- 3.2 Bids shall be made in English.
- 3.3 The bid shall contain no interlineations, erasures or overwriting except as necessary to correct errors made by the Bidder, in which case such corrections shall be signed by the person or persons signing the bid.

4. Submission of Bids

Sealing and Marking of Bids

4.2 The envelopes shall be:

- (a) Addressed to the Purchaser in the following address,

Dy General Manager (CED),
Central Engineering Division,
HLL Lifecare Limited (A Government of India Enterprise),
PB No 2, Peroorkada, Thiruvananthapuram – 695005,
Kerala State, India
Ph: (++91 471) 2433374,2437270 –501,502
Tele Fax: (++ 91 471) 2432647
E-mail: rajeevrv@lifecarehll.com,

- (b) Bear the Enquiry No, closing date and General description of item tendered, and the words "DO NOT OPEN BEFORE" 15.30 Hrs (IST) on 10/11/2017

- 4.3 The envelopes shall indicate the name and address of the Bidder. If the envelope is not sealed and marked as indicated above, the Purchaser will assume no responsibility for the bid's misplacement or premature opening.
- 4.4 Bids should be hand delivered or sent by courier to ensure timely arrival. Telex, cable, e-mail or facsimile bids will be rejected.

Deadline for submission of Bids

	<p align="center">HLL LIFECARE LIMITED, PEROORKADA FACTORY THIRUVANANTHAPURAM 695 005 Phn: 0471 2437270</p>	<p align="right">Pages- 6 of 19</p>
	<p align="center">TENDER FOR THE SUPPLY OF FLAP UNIT AND ACCESSORIES AT HLL,PEROORKADA FATORY</p>	
<p>PLANT : PFT</p>	<p>IFB NO – HLL/PFT/CED/STATIC-TESTING/FLAP UNIT/17</p>	<p>DATE: 27.10.2017</p>

- 4.5 The bids will be received by the Purchaser in the above given address (4.2.a) not later than the date and time specified in the Invitation for Bids.

In the event of the specified date for submission of Bids being declared a holiday for the Purchaser, the bids will be received up to the appointed time on the next working day.

- 4.6 The purchaser may, at its discretion, extend this deadline for submission of bids by amending the Bid Documents or any other reasons in which case all rights and obligations of the Purchaser and Bidders previously subject to the deadline will thereafter be subject to the deadline as extended.
- 4.7 It is the responsibility of the bidders to see that the completed bidding documents whether sent by post or by courier or by person are received in the office of **Dy. General Manager (CED)**, in the above address by the date and time stipulated for receipt as above failing which the bid would be considered late and rejected. Purchaser will not be held responsible for the postal delay, if any, in the delivery of the bidding document or the non-receipt of the same. Bids received after due date and time will be rejected. Mere handing over of the bid documents at reception counter or at any other counter or room or person cannot be considered as submission of bid.

5. Clarification of Bidding Documents

A prospective Bidder requiring any clarification of the Bidding Documents may notify the Purchaser in writing, or by fax at the purchasers mailing address indicated in the Invitation for Bids. The Purchaser will respond in writing to any request for clarification of Bidding Documents, which it receives not later than 7 days prior to the deadline for submission of Bids prescribed by the Purchaser.

6. Amendment of Bidding Documents

- 6.1 At any time prior to the deadline for submission of bids, the Purchaser may, for any reason, modify the Bidding Documents by amendment.
- 6.2 The amendment will be notified in writing or fax or telegram or e-mail to all prospective Bidders, which have received the Bidding Documents and will be binding on them.
- 6.3 In order to afford prospective Bidders reasonable time in which to take the amendment in to account in preparing their bid, the Purchaser may, at its discretion, extend the deadline for the submission of bids.

7. Bid Opening by Purchaser

	<p align="center">HLL LIFECARE LIMITED, PEROORKADA FACTORY THIRUVANANTHAPURAM 695 005 Phn: 0471 2437270</p>	<p align="center">Pages- 7 of 19</p>
	<p align="center">TENDER FOR THE SUPPLY OF FLAP UNIT AND ACCESSORIES AT HLL,PEROORKADA FATORY</p>	
<p>PLANT : PFT</p>	<p>IFB NO – HLL/PFT/CED/STATIC-TESTING/FLAP UNIT/17</p>	<p>DATE: 27.10.2017</p>

- 7.1 The Purchaser will open bids, in the presence of the bidders' representatives who choose to attend, at the date and time specified and in the location given in this document. The Bidders' representatives who are present shall sign a register evidencing their attendance. In the event of the specified date of bid opening being declared a holiday for the Purchaser, the bids shall be opened at the appointed time and location on the next working day.
- 7.2 The Purchaser will prepare appropriate bid opening register and the same shall be signed by bidders present during the opening of the bids and Purchaser.

8. Clarification of bids

To assist in the examination, evaluation and comparison of bids, the purchaser may, at its discretion, ask the bidder for a clarification of its bid. The request for clarification and the response shall be in writing and no change in the price or substance of the bid shall be sought, offered or permitted.

9. Preliminary examination

- 9.1 The purchaser will examine the bids to determine whether they are complete, whether any computational errors have been made, whether the documents have been properly signed, whether the bid validity is as required and whether the bids are generally in order.
- 9.2 Arithmetical errors will be rectified on the following basis. If there is a discrepancy between the unit price and the total price that is obtained by multiplying the unit price and quantity, the unit price shall prevail and the total price shall be calculated. If there is a discrepancy between the words and figures, the amount in words shall prevail.
- 9.3 Prior to the detailed evaluation, the purchaser will determine the substantial responsiveness of each bid to the bidding documents. For purposes of these clauses, a substantially responsive bid is one that conforms to specifications and all the terms and conditions of the bidding documents without material deviation. The purchaser's determination of a bid's responsiveness is to be based on the contents of the bid itself without recourse to extrinsic evidence.
- 9.4 A bid determined as not substantially responsive will be rejected by the purchaser and may not subsequently be made responsive by the bidder by correction of the non-conformity.
- 9.5 The purchaser may waive any minor informality or non-conformity or irregularity in a bid, which does not constitute a material deviation, provided such waiver does not prejudice or affect the relative ranking of any bidder.
- 9.6 The purchaser's determination as to the substantial responsiveness or otherwise of each bid or consideration of a minor informality or non-conformity or irregularity is final and conclusive.

	<p align="center">HLL LIFECARE LIMITED, PEROORKADA FACTORY THIRUVANANTHAPURAM 695 005 Phn: 0471 2437270</p>	<p align="center">Pages- 8 of 19</p>
	<p align="center">TENDER FOR THE SUPPLY OF FLAP UNIT AND ACCESSORIES AT HLL,PEROORKADA FATORY</p>	
<p>PLANT : PFT</p>	<p>IFB NO – HLL/PFT/CED/STATIC-TESTING/FLAP UNIT/17</p>	<p>DATE: 27.10.2017</p>

10. Evaluation and comparison of bids.

- 10.1 The purchaser will technically evaluate all bids previously determined to be responsive and compare the bids previously determined to be substantially responsive and technically acceptable.

11. Post – qualification

- 11.1 Notwithstanding the qualification requirements given in this document, the Purchaser will determine to its satisfaction whether the Bidder selected as having submitted the lowest evaluated responsive bid is qualified to satisfactorily perform the Contract.
- 11.2 The determination will take into account the Bidder's financial, technical and production capabilities. It will be based upon an examination of the documentary evidence of the Bidder's qualifications submitted by the Bidder, as well as such other information as the Purchaser deems necessary and appropriate.
- 11.3 The Purchaser reserves the right to negotiate with the lowest evaluated responsive bidder.
- 11.4 An affirmative determination will be a prerequisite for award of the Contract to the Bidder. A negative determination will result in rejection of the Bidder's bid, in which event the Purchaser will proceed to the next lowest evaluated bid to make a similar determination of that bidder's capabilities to perform satisfactorily.
- 11.5 Conditional Bids shall not be entertained.

12. Award Criteria

The Purchaser will award the Contract to the successful Bidder whose bid has been determined to be substantially responsive and has been determined as the lowest evaluated bid provided further that the Bidder is determined to be qualified to perform the Contract satisfactorily for the items offered.

13. Notification of Award

- 13.1 Prior to the expiration of the period of bid validity, the purchaser will notify the successful Bidder in writing by post or by cable or telex or fax, to be confirmed in writing by post, that its bid has been accepted. The notification of award may be sent in the form of Letter of Intend / Supply or Work order.
- 13.2 The signed acceptance of the notification of award by the Supplier/Contractor will constitute a concluded contract..

	HLL LIFECARE LIMITED, PEROORKADA FACTORY THIRUVANANTHAPURAM 695 005 Phn: 0471 2437270	Pages- 9 of 19
	TENDER FOR THE SUPPLY OF FLAP UNIT AND ACCESSORIES AT HLL,PEROORKADA FATORY	
PLANT : PFT	IFB NO – HLL/PFT/CED/STATIC-TESTING/FLAP UNIT/17	DATE: 27.10.2017

SCHEDULE II

DETAILED SPECIFICATION OF ITEM

Requirement:

We are in the in the process of fabricating Electronic Testing Machine(Dual Station) for testing male condoms. For the proposed machine, we require the following item as per the specifications given below:

1.Flapon unit & Accessories

Technical Data and Specification

ITEM NO.	PART NUMBER	DESCRIPTION	QTY.
1	Bottom support of testing flap	HLL-CED-D5-057-00	2
2	Mounting plate	HLL-CED-D5-089-00	2
3	Holder for testing flap shaft	HLL-CED-D5-090-00	2
4	Carbon rod	HLL-CED-D5-058-00	4
5	Carbon rod holder	HLL-CED-D5-059-00	4
6	Flap fixing shafts	HLL-CED-D5-062-00	12
7	Middle piece	HLL-CED-D5-065-00	2
8	Spring	HLL-CED-D5-071-00	4
9	Shaft for flap support fixing	HLL-CED-D5-084-00	2
10	M6x15(L)	STD ITEM	8
11	M8x130(L) SHD BOLT	HLL-CED-D5-064-00	2
12	Top support of flap	HLL-CED-D5-074-00	2
13	Bottom support of flap	HLL-CED-D5-057-00	2
14	Flap fixing roller	HLL-CED-D5-061-00	2
15	Coller for testing flap	HLL-CED-D5-060-00	4
16	Flap for RRT	UNDER HLL SCOPE	4

	HLL LIFECARE LIMITED, PEROORKADA FACTORY THIRUVANANTHAPURAM 695 005 Phn: 0471 2437270	Pages- 10 of 19
	TENDER FOR THE SUPPLY OF FLAP UNIT AND ACCESSORIES AT HLL,PEROORKADA FATORY	
PLANT : PFT	IFB NO – HLL/PFT/CED/STATIC-TESTING/FLAP UNIT/17	DATE: 27.10.2017

17	M6x10 mm grub screw	STD ITEM	24
18	M10X55	STD ITEM	4
19	M10 FLAT WASHER	STD ITEM	4
20	M10 Spring washer	STD ITEM	4
21	M10 nut	STD ITEM	2
22	M6x30 bolt	STD ITEM	2
23	M6 plane washer	STD ITEM	2
24	M6 spring wagher	STD ITEM	4
25	Bearing 608-2RS	STD ITEM	2
26	M5x30 mm SHD Bolt	STD ITEM	8
27	M4X40 (SLOTTED FLAT)	STD ITEM	4
28	M4 HEX NUT	STD ITEM	4
29	Testing flap stiffner	HLL-CED-D5-072-00	2
30	M6x20	STD ITEM	6
31	M6 nut	STD ITEM	4
32	Bottom support anchor of testing flap stem	HLL-CED-D5-091-00	2
33	Rubber disc support base plate	HLL-CED-D5-067-00	
34	Hollow Shaft for rubber roller	HLL-CED-D5-063-00	
35	Shaft	HLL-CED-D5-070-00	
36	Rubber roller	HLL-CED-D5-076-00	
37	Pylley for rubber disc	HLL-CED-D5-066-00	
38	Bottom pulley of testing flap	HLL-CED-D5-053-00	
39	62022ZC3 bearing		
40	Top sapcer	HLL-CED-D5-073-00	
41	Bottom spacer-1	HLL-CED-D5-056-00	
42	Bottom spacer-2	HLL-CED-D5-056-00	
43	Nut m10-6		

	HLL LIFECARE LIMITED, PEROORKADA FACTORY THIRUVANANTHAPURAM 695 005 Phn: 0471 2437270	Pages- 11 of 19
	TENDER FOR THE SUPPLY OF FLAP UNIT AND ACCESSORIES AT HLL,PEROORKADA FATORY	
PLANT : PFT	IFB NO – HLL/PFT/CED/STATIC-TESTING/FLAP UNIT/17	DATE: 27.10.2017

44	Washer(10 mm)	STD ITEM	
45	M6x15(L) SHD	STD ITEM	
46	M6x30 bolt	STD ITEM	
47	M6 nut	STD ITEM	
48	M6 plane washer	STD ITEM	
49	M6 spring wagher	STD ITEM	

GENERAL CONDITIONS

- 1) Given specification are indicative only. The supplier should visit the HLL Site at Peroorkada Factory, Thiruvanthapuram and see the machines and also take their own assessments before quoting of bids. Prior permission from HLL shall be taken for visiting the plant. No photographs will be allowed inside the plant. The purchaser will not be responsible for any wrong quotes due to inadequate information.
- 2) The item should be complete with all accessories and interconnections.
- 3) The bidder should attach to their bid detailed specifications, catalogues and other details of all the items quoted by them (If necessary)
- 4) Calibration certificates with traceability to National Standards shall be supplied for all the instruments coming under the scope of supply of supplier. (If necessary)
- 5) The supplier should submit necessary test certificates as per relevant standards of material used, free of cost.
- 6) The suppliers should submit the following documents, relevant to their scope of work, two weeks prior to the commissioning of the Unit :
 - a) All final drawings
 - b) Relevant Test Certificates, Guarantee Certificate for each material which are using for fabrication.
 - c) Any other related documents
- 7) Any deviations from the bid documents shall be clearly indicated.
- 8) The bid should be complete with all the relevant details.

	<p align="center">HLL LIFECARE LIMITED, PEROORKADA FACTORY THIRUVANANTHAPURAM 695 005 Phn: 0471 2437270</p>	<p align="center">Pages- 12 of 19</p>
	<p align="center">TENDER FOR THE SUPPLY OF FLAP UNIT AND ACCESSORIES AT HLL,PEROORKADA FATORY</p>	
<p>PLANT : PFT</p>	<p>IFB NO – HLL/PFT/CED/STATIC-TESTING/FLAP UNIT/17</p>	<p>DATE: 27.10.2017</p>

SCHEDULE III

CONDITIONS OF CONTRACT

1. Price

The price quoted should be inclusive of Basic Price, all applicable taxes and duties including GST, Entry tax, Octroi & other levies, P&F charges, insurance charges etc for supply of items FOR HLL site. The Supplier should pay entry taxes, as applicable and should be included in the offer.

Price quoted should be firm without any escalation till the order is completely executed.

2. Taxes/Duties/Levies

The supplier/contractor shall be entirely responsible for all taxes including entry tax, duties, license fees, etc. incurred until successful completion of contract. All central, state, municipal taxes, duties and levies payable shall be shown by the bidder separately in the Bid.

Note:

The term 'Machine' means the final and complete equipment/machinery as ordered and does not mean raw material, components, consumable, etc. required for the work. The Purchaser shall not be liable to pay any tax/duty/levy incurred during the transactions between the Supplier and his sub-suppliers and or Agents.

3. Insurance

The supplier shall arrange insurance coverage for transit, storage and erection.

4. Delivery/Completion Period

The equipment and its accessories should be delivered within **4 Weeks** from the date of Letter Of Intent or Order.

Time being the essence of the Contract, the delivery, stipulated should be strictly adhered to. Delay in delivery/non delivery of the equipment will cause loss and/or damage to Purchaser. The delivery period shall be counted from the date of sending of Purchaser's intimation of acceptance of the Supplier's offer (Letter of Intent (LOI) and/or order).

	HLL LIFECARE LIMITED, PEROORKADA FACTORY THIRUVANANTHAPURAM 695 005 Phn: 0471 2437270	Pages- 13 of 19
	TENDER FOR THE SUPPLY OF FLAP UNIT AND ACCESSORIES AT HLL,PEROORKADA FATORY	
PLANT : PFT	IFB NO – HLL/PFT/CED/STATIC-TESTING/FLAP UNIT/17	DATE: 27.10.2017

5. Terms Of Payment

The payment terms offered are as follows: -

- a) 70% of the total value of equipment/s will be paid against supply and acceptance of item/equipments at site.
- b)
- c) Balance 20% against trial run and satisfactory performance
- d) Balance 10% of the value of the equipment/s will be paid after the guarantee period of one year.

Tax Deduction: All statutory deductions like Income Tax or any other government-imposed liabilities shall be borne by the Supplier/Contractor (as applicable at the time of execution of job) and shall be deducted from each bill submitted by the Supplier/Contractor.

6. Guarantee Period

The Guarantee against any possible manufacturing defects shall be given for a period of 18 months from the date of supply and acceptance of the items at HLL site or 12 months from the date of installation, whichever is earlier.

7. Liquidated damages for delays

If the equipment is not supplied to the purchaser within the time stipulated in the Order, Purchaser may at their option, either (1) recover from the Supplier/Contractor liquidated damages at the rate of 0.5 % of the total contract value for every week of delay, subject to a maximum of 7.5 % of the total contract value, or (2) at the risk and cost of the Supplier and without prejudice to the other remedies/rights as per the Contract, terminate the order wholly or partially and complete it themselves or reassign it to other Suppliers/Contractors.

8. Inspection And Testing

Purchaser shall have the right of access to the Supplier's/Contractor's works at all reasonable times to inspect and measure the progress of execution of the Order. The Supplier/Contractor should make available all tools, instruments, apparatus, equipment, facilities, services and materials to enable the Purchaser's nominee to carryout such inspection/tests without obligations. Notwithstanding such tests/inspection conducted at the Supplier's works from time to time, goods under the Order shall not be dispatched unless they have been finally inspected by the purchaser or inspection waived and dispatch specifically authorized in writing, wherever inspection during various stages of execution of the order and prior to dispatch are specifically provided for in the order, sufficient advance notice shall be given to the purchaser for the purpose, and as a consequence of such inspection, if necessary, the Supplier shall arrange re-work at his own cost. Notwithstanding any such inspection/tests carried out at Supplier's works, the equipment shall be accepted only after receipt and successful commissioning at the site and the inspection/tests

	HLL LIFECARE LIMITED, PEROORKADA FACTORY THIRUVANANTHAPURAM 695 005 Phn: 0471 2437270	Pages- 14 of 19
	TENDER FOR THE SUPPLY OF FLAP UNIT AND ACCESSORIES AT HLL,PEROORKADA FATORY	
PLANT : PFT	IFB NO – HLL/PFT/CED/STATIC-TESTING/FLAP UNIT/17	DATE: 27.10.2017

carried out at Supplier's works will not relieve his contractual obligations for conforming to the specifications under the Order.

9. Performance Guarantee

The Supplier shall fully guarantee all of the equipment supplied to perform in accordance with the specifications and to be free of all defects in design, material and workmanship. Should any equipment not performing as intended or should the design, material or workmanship prove defective within a period of 12 months from the date of successful commissioning, the equipment shall, upon notification of deficiency or defect, be promptly corrected by the Supplier to the satisfaction of Purchaser without delay and at no extra cost. If the Supplier fails to take proper corrective action to replace or repair the deficiency within a reasonable time of Purchaser's notification to this effect, the Purchaser shall be free to take such corrective action at the Supplier's risk and cost.

10. Scope of Services, Supplies and Materials:

The scope will include all services, supplies etc. for the satisfactory execution of the Contract except in so far as any of those are expressly excluded.

11. Force Majeure

- a. Neither the Supplier nor the Purchaser shall be considered in default in the performance of their obligations as per the Contract so long as such performance is prevented or delayed because of strikes, war, hostilities, revolution, civil commotion, epidemics, accidents, fire, cyclone, flood or because of any law and order proclamation, regulation or ordinance of Government or subdivision thereof or because of any act of God. The proof of existence of force majeure shall be provided by the party claiming it to the satisfaction of the other.
- b. The Supplier shall advise Purchaser initially by a Fax, followed by post, the beginning and end of any of the above causes of delay, failing which Purchaser shall not be liable to consider delays due to the above reasons. Notice as stated above should be given even in case where only the Supplier's bids are under the consideration of the Purchaser and no acceptance of the same has been given and detailed order issued.
- c. In the event of definite delay even if arising out of reasons due to force majeure, Purchaser shall have the right at their discretion to cancel the Order or part of the Order without any liability on their part to make any payment to the Supplier while reserving the right to claim refund of and any payment if advanced or paid to Supplier.

12. Assignment And Subletting

No assignment and subletting of whole or part of the order shall be permitted except with prior approval of purchase obtained in writing.

13. Correspondence

	HLL LIFECARE LIMITED, PEROORKADA FACTORY THIRUVANANTHAPURAM 695 005 Phn: 0471 2437270	Pages- 15 of 19
	TENDER FOR THE SUPPLY OF FLAP UNIT AND ACCESSORIES AT HLL,PEROORKADA FATORY	
PLANT : PFT	IFB NO – HLL/PFT/CED/STATIC-TESTING/FLAP UNIT/17	DATE: 27.10.2017

All correspondence relating to this enquiry shall be in English, to:

Dy. General Manager (CED)
HLL Lifecare Limited,
Peroorkada Factory,
Thiruvananthapuram 695005

14. Indemnification Clause

The Supplier shall indemnify and hold harmless the Purchaser from and against all claims, liability, loss damage or expense, including counsel fees arising from or by reason of any actual or claimed trade mark, patent or copy right infringement or any litigation based thereon with respect to any part of the items covered by the Contract, and such obligations shall survive acceptance of payment for the items.

15. Entirety of the Agreement

All of the terms agreed to between the Supplier and Purchaser will be included in the Purchase/work Order/Contract and no their communication, proposal or understanding, written, oral or implied, will be considered to be included in the Purchase/work Order/Contract or form part of the Contract between the Supplier and Purchaser unless specifically agreed to in that behalf in writing between Purchaser and Supplier.

16. Settlement Of Disputes

Arbitration shall not be a means of settlement of any dispute or claim arising out of the contract relating to the work. Any disputes or difference arising between the parties with respect to the performance of any part of this agreement or any thing connected therewith, etc shall as far as possible be mutually settled by the process of dialog and negotiation.

The Courts at Thiruvananthapuram alone shall have jurisdiction in respect of settlement of any matter arising out or in connection with the contract.

	HLL LIFECARE LIMITED, PEROORKADA FACTORY THIRUVANANTHAPURAM 695 005 Phn: 0471 2437270	Pages- 16 of 19
	TENDER FOR THE SUPPLY OF FLAP UNIT AND ACCESSORIES AT HLL,PEROORKADA FATORY	
PLANT : PFT	IFB NO – HLL/PFT/CED/STATIC-TESTING/FLAP UNIT/17	DATE: 27.10.2017

SCHEDULE IV

FORMAT FOR QUOTING

Sl. No	Item/Work Short Description	Unit	Quantity	Rate in Rs	Amount in Rs
1	Bottom support of testing flap	No	2		
2	Mounting plate	No	2		
3	Holder for testing flap shaft	No	2		
4	Carbon rod	No	4		
5	Carbon rod holder	No	4		
6	Flap fixing shafts	No	12		
7	Middle piece	No	2		
8	Spring	No	4		
9	Shaft for flap support fixing	No	2		
10	M6x15(L)	No	8		
11	M8x130(L) SHD BOLT	No	2		
12	Top support of flap	No	2		
13	Bottom support of flap	No	2		
14	Flap fixing roller	No	2		
15	Coller for testing flap	No	4		
16	Flap for RRT	No	4		
17	M6x10 mm grub screw	No	24		
18	M10X55	No	4		
19	M10 FLAT WASHER	No	4		
20	M10 Spring washer	No	4		

	HLL LIFECARE LIMITED, PEROORKADA FACTORY THIRUVANANTHAPURAM 695 005 Phn: 0471 2437270	Pages- 17 of 19
	TENDER FOR THE SUPPLY OF FLAP UNIT AND ACCESSORIES AT HLL,PEROORKADA FATORY	
PLANT : PFT	IFB NO – HLL/PFT/CED/STATIC-TESTING/FLAP UNIT/17	DATE: 27.10.2017

21	M10 nut	No	2		
22	M6x30 bolt	No	2		
23	M6 plane washer	No	2		
24	M6 spring wagher	No	4		
25	Bearing 608-2RS	No	2		
26	M5x30 mm SHD Bolt	No	8		
27	M4X40 (SLOTTED FLAT)	No	4		
28	M4 HEX NUT	No	4		
29	Testing flap stiffner	No	2		
30	M6x20	No	6		
31	M6 nut	No	4		
32	Bottom support anchor of testing flap stem	No	2		
33	Rubber disc support base plate	No	2		
34	Hollow Shaft for rubber roller	No	2		
35	Shaft	No	2		
36	Rubber roller	No	2		
37	Pylley for rubber disc	No	2		
38	Bottom pulley of testing flap	No	2		
39	62022ZC3 bearing	No	4		
40	Top sapcer	No	2		

	HLL LIFECARE LIMITED, PEROORKADA FACTORY THIRUVANANTHAPURAM 695 005 Phn: 0471 2437270	Pages- 18 of 19
	TENDER FOR THE SUPPLY OF FLAP UNIT AND ACCESSORIES AT HLL,PEROORKADA FATORY	
PLANT : PFT	IFB NO – HLL/PFT/CED/STATIC-TESTING/FLAP UNIT/17	DATE: 27.10.2017

41	Bottom spacer-1	No	2		
42	Bottom spacer-2	No	2		
43	Nut m10-6	No	4		
44	Washer(10 mm)	No	4		
45	M6x15(L) SHD	No	2		
46	M6x30 bolt	No	8		
47	M6 nut	No	8		
48	M6 plane washer	No	8		
49	M6 spring wاهر	No	8		

AMOUNT IN RS (EX WORKS)

EXCISE & OTHER DUTIES

GST

PACKING & FORWARDING CHARGES

GST

ENTRY TAX, OCTROI AND OTHER LEVIES, IF ANY

FREIGHT CHARGES INCLUDING TRANSIT INSURANCE

**SUPPLY PRICE F.O.R HLL SITE, Peroorkada,
THIRUVANANTHAPURAM**

(RUPEES IN WORDS)

I hereby agree to supply/execute the item/work specified at the above quoted rate/amount.

SUPPLIER/CONTRACTOR

	<p align="center">HLL LIFECARE LIMITED, PEROORKADA FACTORY THIRUVANANTHAPURAM 695 005 Phn: 0471 2437270</p>	<p align="center">Pages- 19 of 19</p>
	<p align="center">TENDER FOR THE SUPPLY OF FLAP UNIT AND ACCESSORIES AT HLL,PEROORKADA FATORY</p>	
<p>PLANT : PFT</p>	<p>IFB NO – HLL/PFT/CED/STATIC-TESTING/FLAP UNIT/17</p>	<p>DATE: 27.10.2017</p>

**SCHEDULE V
ACCEPTANCE FORM**

(To be submitted in the letter head of the firm indicating full name and address, telephone & fax numbers etc.)

From

Date :

To

Dy General Manager (CED),
Central Engineering Division,
HLL Lifecare Limited (A Government of India Enterprise),
PB No 2, Peroorkada, Thiruvananthapuram – 695005,
Kerala State, India
Ph: (++91 471) 2433374,2437270 –501,502
Tele Fax: (++ 91 471) 2432647
E-mail: rajeevrv@lifecarehll.com

Dear Sir,

I / We, hereby offer to design/fabricate/supply/commission as detailed in schedule hereto or such portion thereof as you may specify in the acceptance of Bid at the price given in the price schedule and agree to hold this offer open till 90 days after the date of bid opening prescribed by the purchaser. I/We have understood the terms and conditions mentioned in the invitation for bid and Conditions of Contract furnished by you and have thoroughly examined the specifications in the bid document hereto and are fully aware of the nature of the scope of work required and my/our offer is to comply strictly in accordance with the requirement and the terms and conditions mentioned above.

Yours faithfully,

SIGNATURE OF THE BIDDER

ITEM NO.	PART NUMBER	DESCRIPTION	QTY.
1	Bottom support of testing flap	HLL-CED-D5-057-00	1
2	Mounting plate	HLL-CED-D5-089-00	1
3	Holder for testing flap shaft	HLL-CED-D5-090-00	1
4	Carbon rod	HLL-CED-D5-058-00	2
5	Carbon rod holder	HLL-CED-D5-059-00	2
6	Flap fixing shafts	HLL-CED-D5-062-00	6
7	Middle piece	HLL-CED-D5-065-00	1
8	Spring	HLL-CED-D5-071-00	2
9	Shaft for flap support fixing	HLL-CED-D5-084-00	1
10	M6x15(L)	HLL-CED-D5-085-00	4
11	M8x130(L) SHD BOLT	HLL-CED-D5-064-00	1
12	Top support of flap	HLL-CED-D5-074-00	1
13	Bottom support of flap	HLL-CED-D5-057-00	1
14	Flap fixing roller	HLL-CED-D5-061-00	1
15	Coller for testing flap	HLL-CED-D5-060-00	2
16	Flap for RRT	UNDER HLL SCOPE	2
17	M6x10 mm grub screw	STD ITEM	12
18	M10X55	STD ITEM	2
19	M10 FLAT WASHER	STD ITEM	2
20	M10 Spring washer	STD ITEM	2
21	M10 nut	STD ITEM	1
22	M6x30 bolt	STD ITEM	1
23	M6 plane washer	STD ITEM	1
24	M6 spring wاهر	STD ITEM	2
25	Bearing 608-2RS	STD ITEM	1
26	M5x30 mm SHD Bolt	STD ITEM	4
27	M4X40 (SLOTTED FLAT)	STD ITEM	2
28	M4 HEX NUT	STD ITEM	2
29	Testing flap stiffner	HLL-CED-D5-072-00	1
30	M6x20	STD ITEM	3
31	M6 nut	STD ITEM	2
32	Bottom support anchor of testing flap stem	HLL-CED-D5-091-00	1

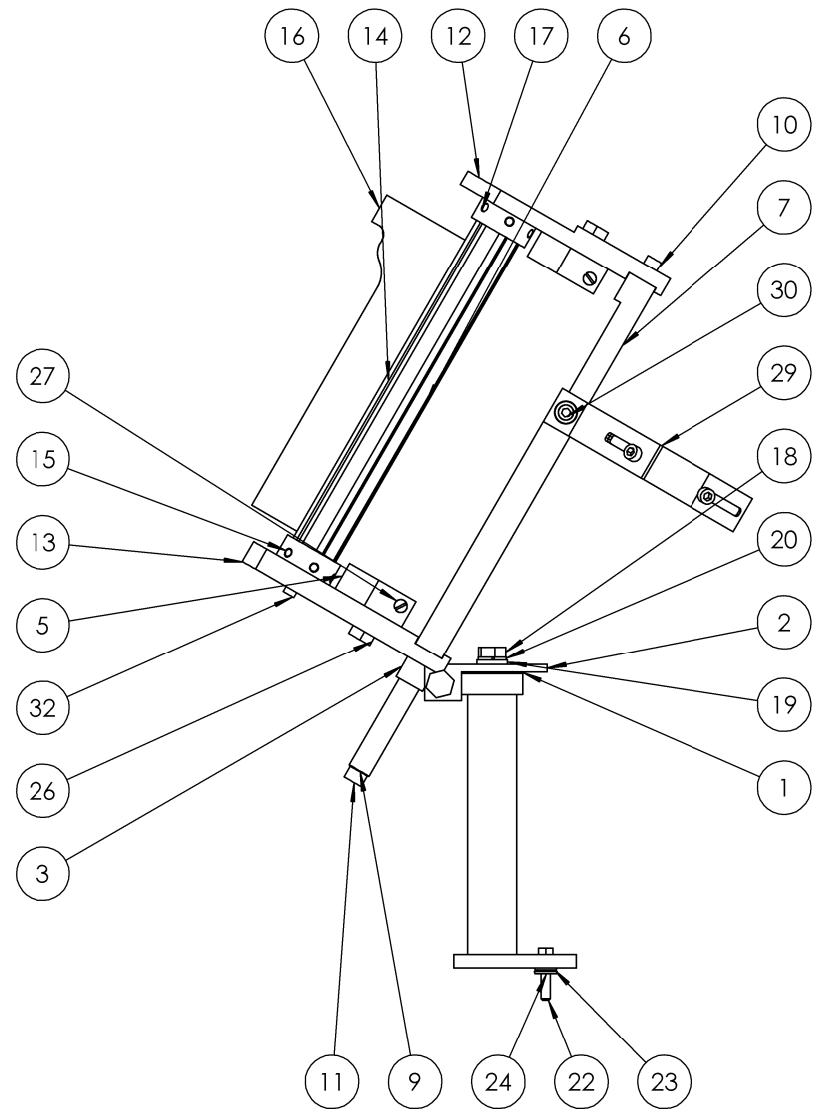
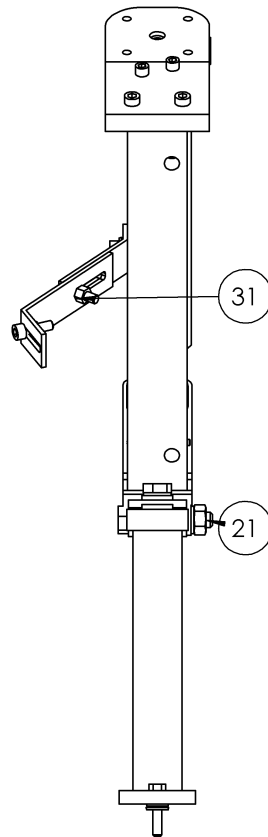

MATERIAL AS SPECIFIED		HLL Lifecare Limited Thiruvananthapuram - 05	QTY 01 No
DRAWN BY	RAJKIRAN	TITLE Testing flap assembly	
CHECKED BY		DRG NO: HLL-CED-D5-075-00	
APPROVED BY		SHEET NO : 01/01	
DATE	25-10-2017	REV: _____ DATE: _____	
SCALE	NTS	ALL DIMENSIONS ARE IN MM	

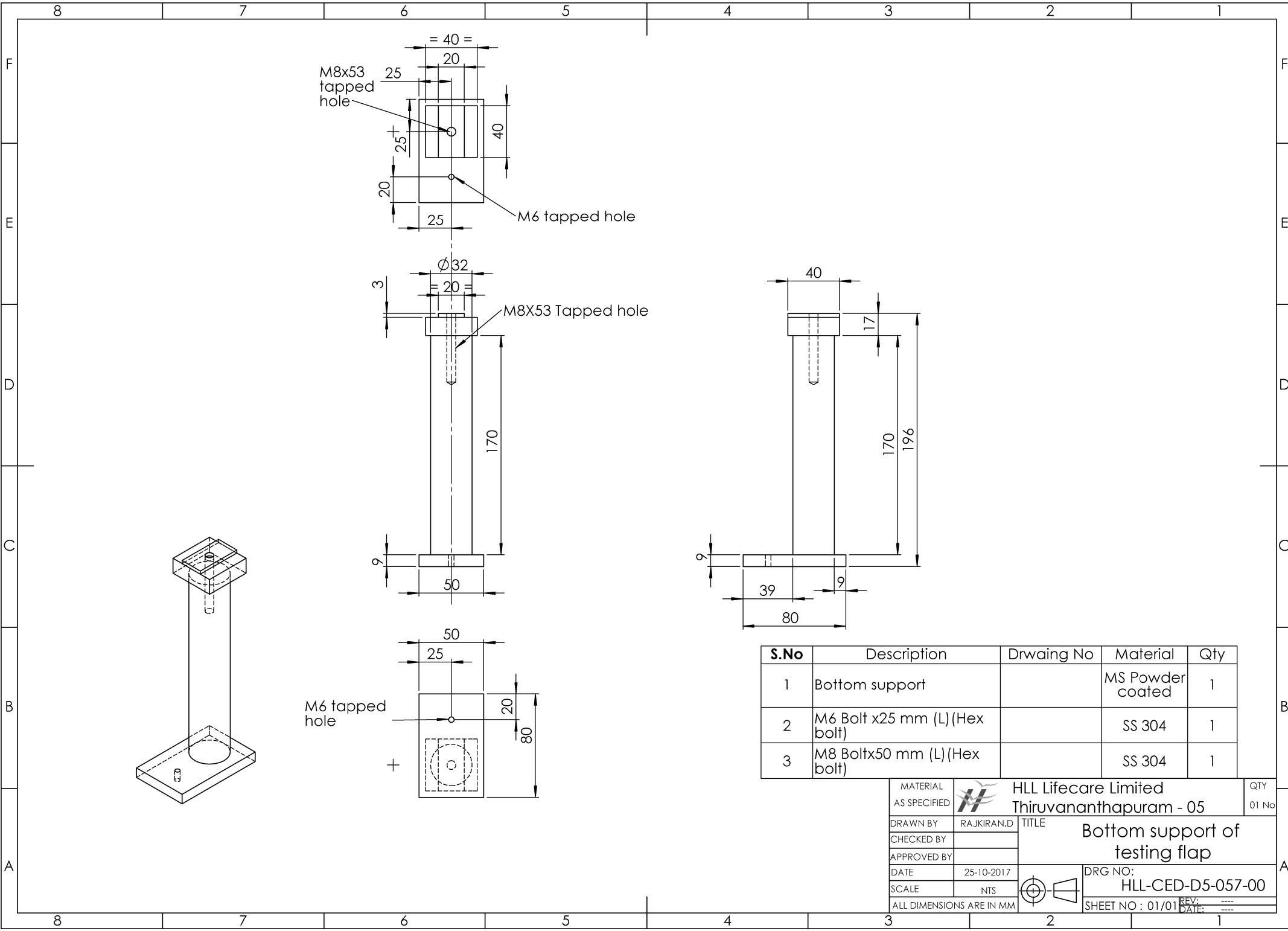

S.No	Description	Drwaing No	Material	Qty
1	Bottom support		MS Powder coated	1
2	M6 Bolt x25 mm (L)(Hex bolt)		SS 304	1
3	M8 Boltx50 mm (L)(Hex bolt)		SS 304	1

MATERIAL AS SPECIFIED		HLL Lifecare Limited Thiruvananthapuram - 05		QTY 01 No
DRAWN BY		RAJKIRAN.D	TITLE Bottom support of testing flap	
CHECKED BY		DRG NO: HLL-CED-D5-057-00		
APPROVED BY		SHEET NO : 01/01		REV: ----- DATE: -----
DATE	25-10-2017	ALL DIMENSIONS ARE IN MM		
SCALE	NTS			

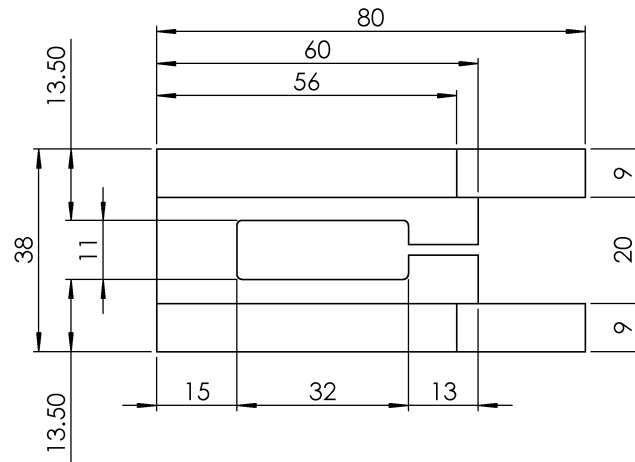
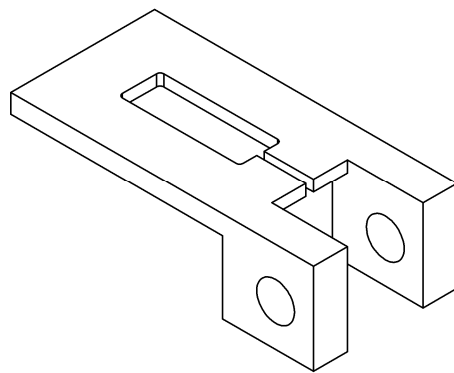
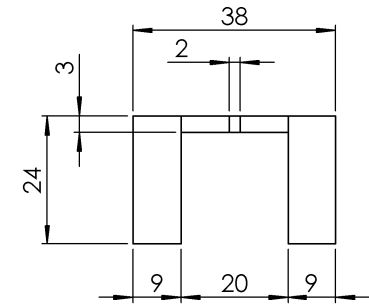
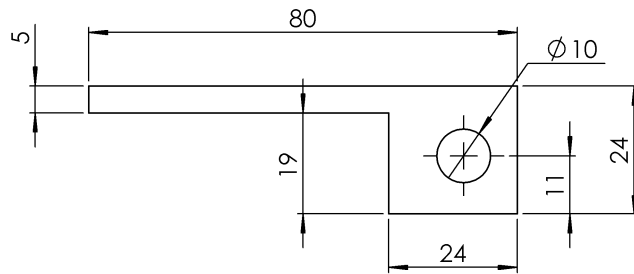
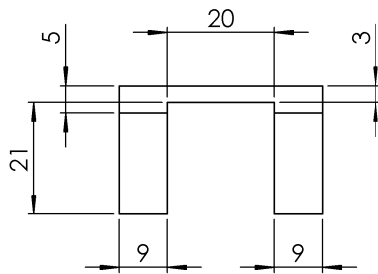
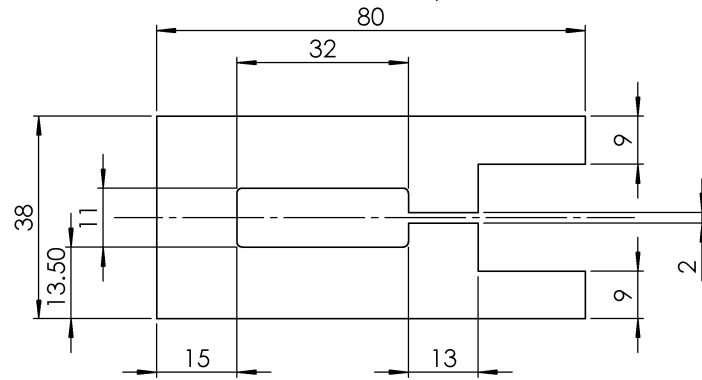

S.No	Description	Drawing No	Material	Qty
1	Mounting plate		SS 304	1
2	M10X53(L) Bolt		SS304	1
3	Plain washer Suitable for M10 bolt		SS304	1
4	Spring washer Suitable for M10 bolt		IS4072	1

MATERIAL AS SPECIFIED		HLL Lifecare Limited Thiruvananthapuram - 05	QTY 01 No
DRAWN BY	RAJKIRAN	TITLE MOUNTING PLATE	
CHECKED BY		DRG NO: HLL-CED-D5-089-00	
APPROVED BY		SHEET NO : 01/01	
DATE	25-10-2017	REV: -----	DATE: -----
SCALE	NTS	ALL DIMENSIONS ARE IN MM	

4 3 2 1

F

F

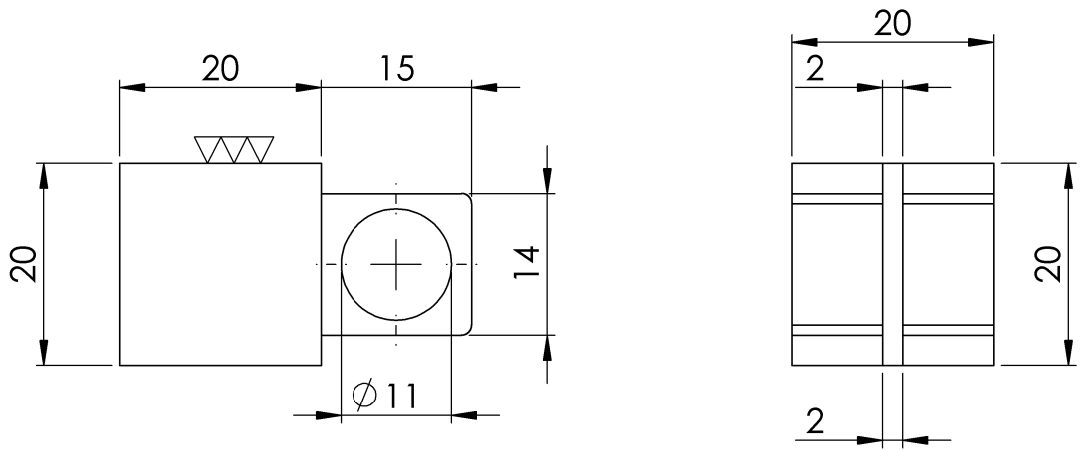

E

E

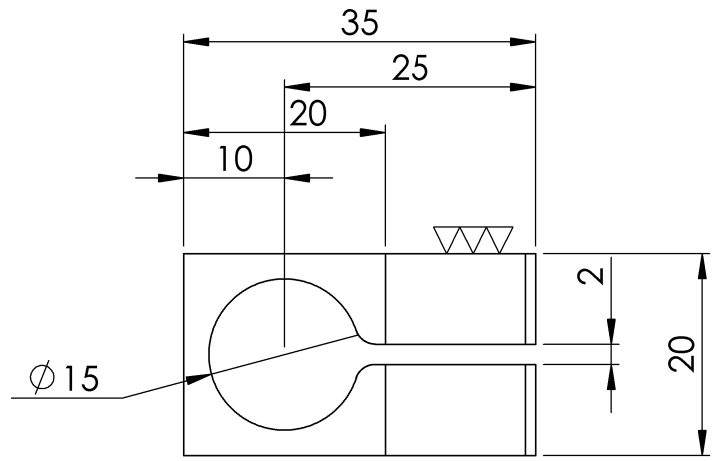

D

D

C

C

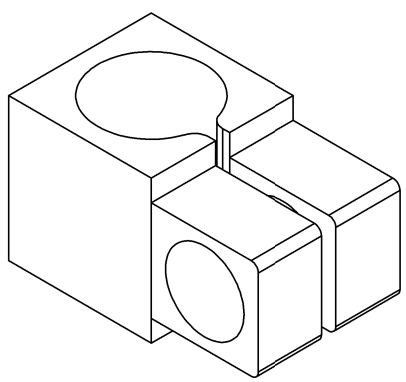

B

B

S.No	Description	Drawing No	Material	Qty
1	Holder for testing flap shaft		SS 304	1

Weight of the Component : g (approx.)

HLL Lifecare Limited
Thiruvananthapuram - 05

A

A

MATERIAL AS SPECIFIED		TITLE		QTY
DRAWN BY	RAJKIRAN	Holder for testing flap shaft		
CHECKED BY				
APPROVED BY				
DATE	25-10-2017	DRG NO:	HLL-CED-D5-090-00	
SCALE	NTS	SHEET NO: 01/01	REV:	
ALL DIMENSIONS ARE IN MM			DATE:	

4 3 2 1

4

3

2

1

F

F

E

E

D

D

C

C

B

B

A

A

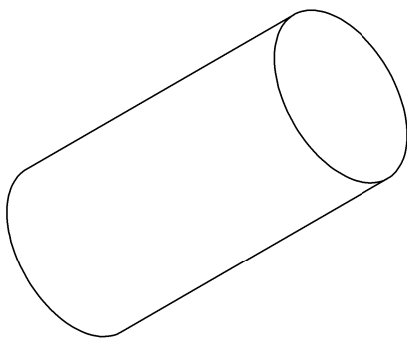
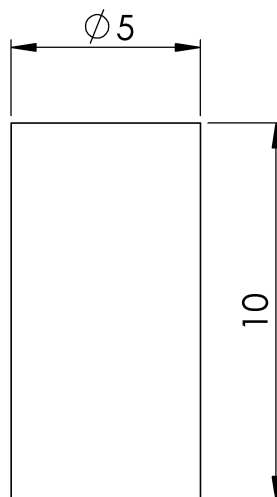
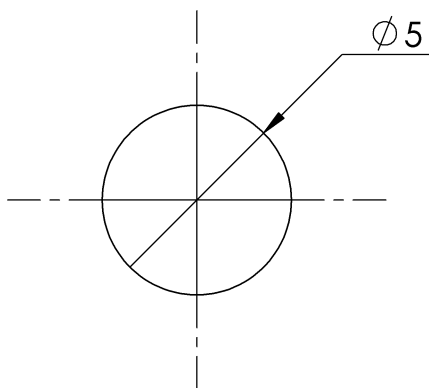

S.No	Description	Drawing No	Material	Qty
1	Conductive type Carbon rod	HLL-CED-D5-058-00	Conductive graphite	1

Weight of the Component : g (approx.)

MATERIAL
AS SPECIFIED



HLL Lifecare Limited
Thiruvananthapuram - 05

QTY
01 No

DRAWN BY RAJKIRAN
CHECKED BY SARATH
APPROVED BY KRK

TITLE

Carbon rod

DATE 17.01.2017

SCALE NTS

ALL DIMENSIONS ARE IN MM

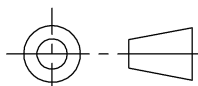

DRG NO: HLL-CED-D5-058-00

SHEET NO: 01/01

REV:
DATE:

4

3

2

1

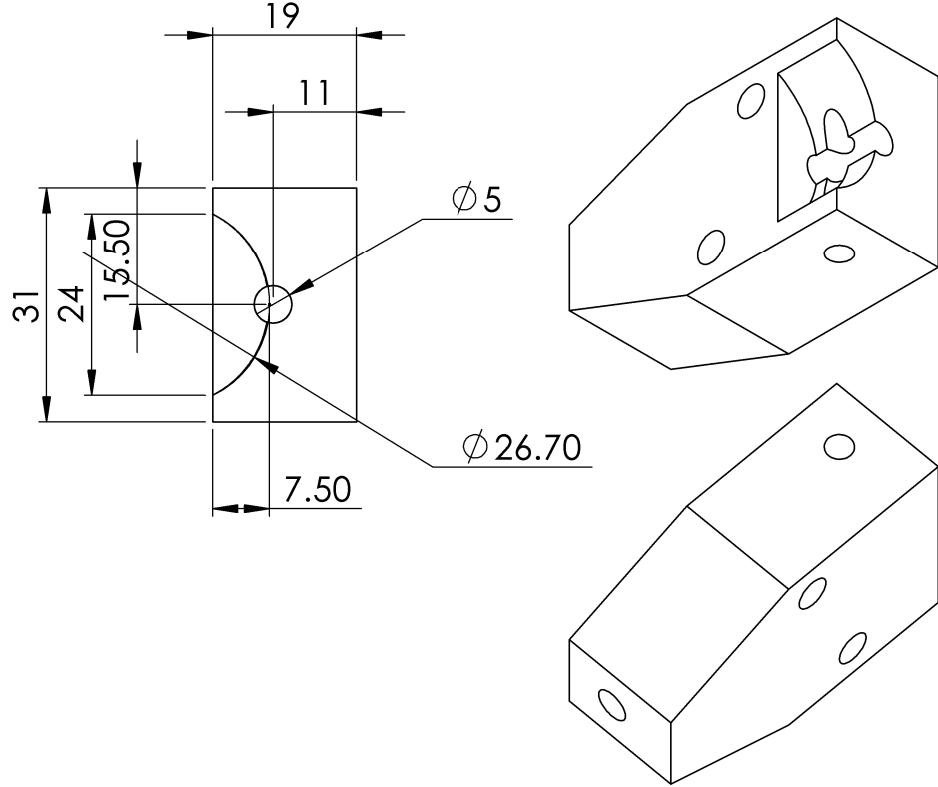
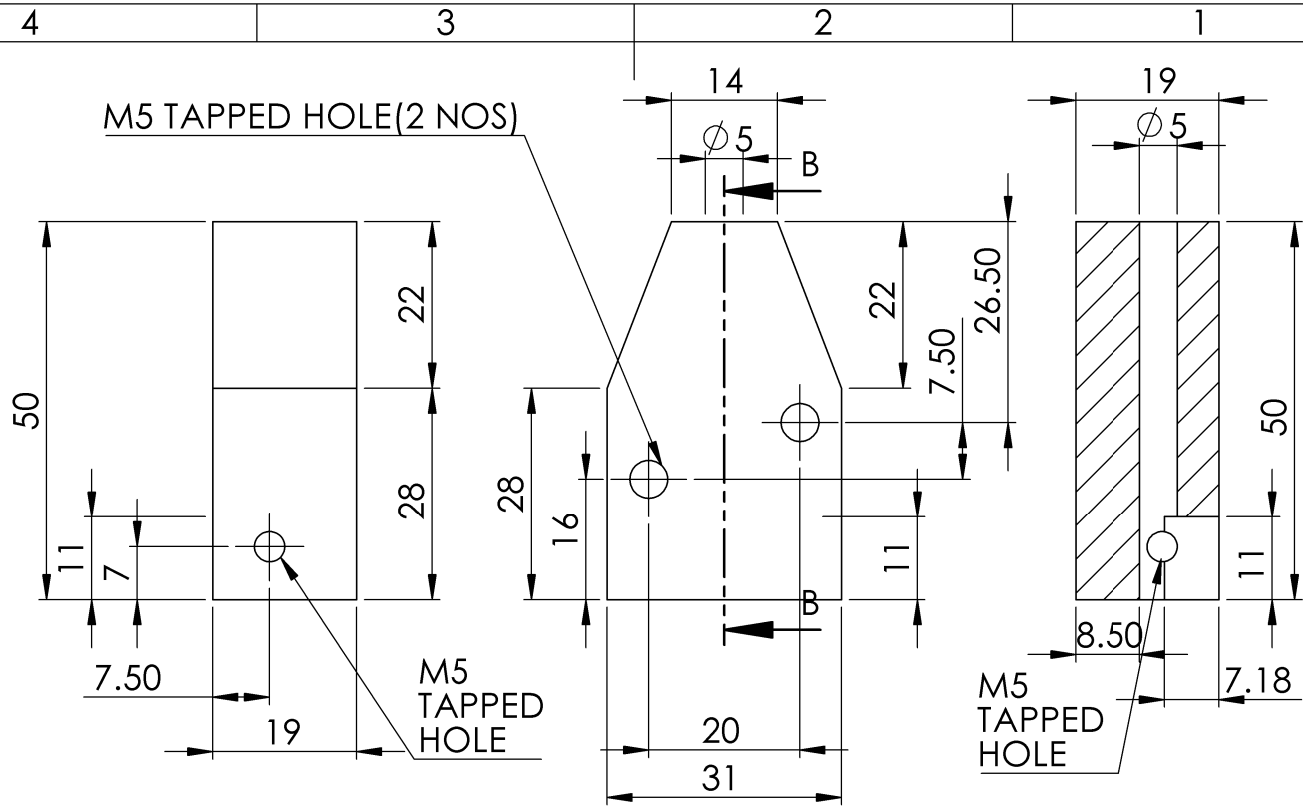

S.No	Description	Drawing No	Material	Qty
1	Carbon rod holder	HLL-CED-D5-059-00	Bakelite/ hylem	1

Weight of the Component : g (approx.)

MATERIAL AS SPECIFIED		HLL Lifecare Limited Thiruvananthapuram - 05	QTY 01 No
-----------------------	---	---	--------------

DRAWN BY	RAJKIRAN	TITLE Carbon rod holder
CHECKED BY	SARATH	
APPROVED BY	KRK	

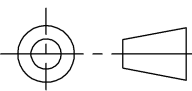
DATE	17.01.2017		DRG NO:	HLL-CED-D5-059-00
SCALE	NTS		SHEET NO:	01/01
ALL DIMENSIONS ARE IN MM			REV:	
			DATE:	

4

3

2

1

F

F

E

E

D

D

C

C

B

B

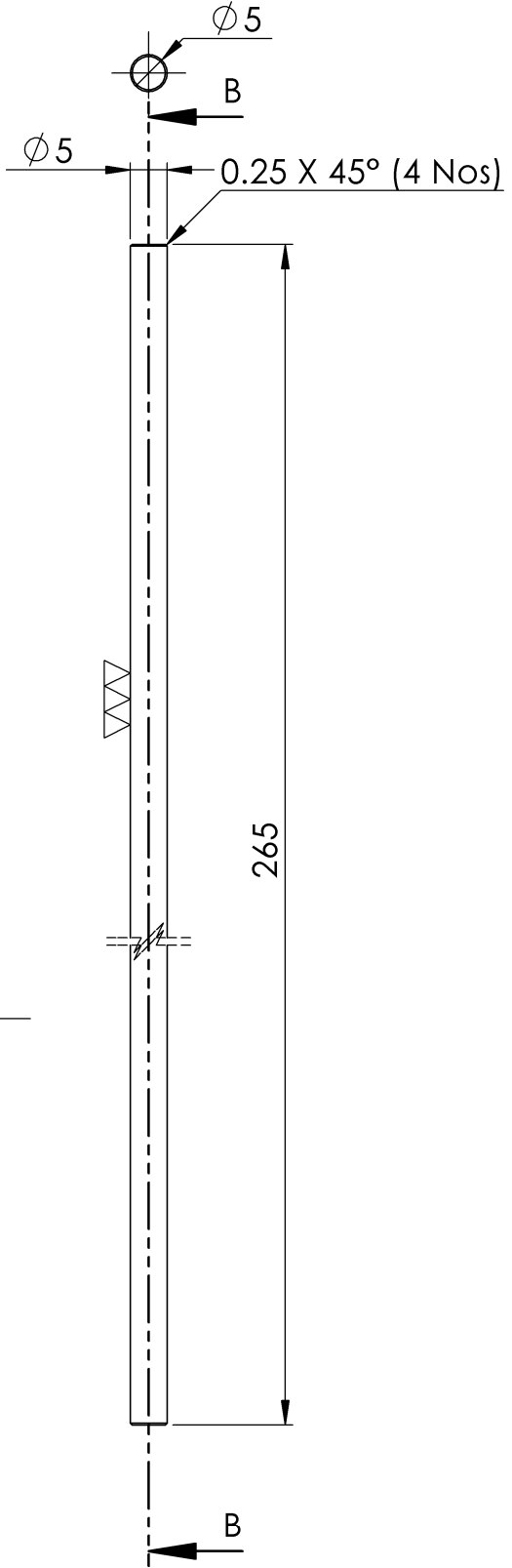

Weight of the Component : g (approx.)

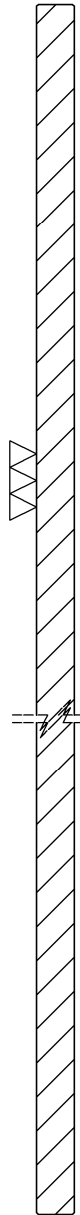

SECTION B-B
SCALE 1 : 1

S.No	Description	Drawing No	Material	Qty
1	Flap fixing shafts	HLL-CED-D5-062-00	SS 304	1

MATERIAL
AS SPECIFIED



HLL Lifecare Limited
Thiruvananthapuram - 05

QTY
01 No

DRAWN BY	RAJKIRAN
CHECKED BY	SARATH
APPROVED BY	KRK

TITLE
Flap fixing shafts

DATE	17.01.2017
SCALE	NTS
ALL DIMENSIONS ARE IN MM	

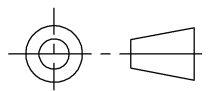

DRG NO:	HLL-CED-D5-062-00
SHEET NO:	01/01
REV:	
DATE:	

4

3

2

1

A

A

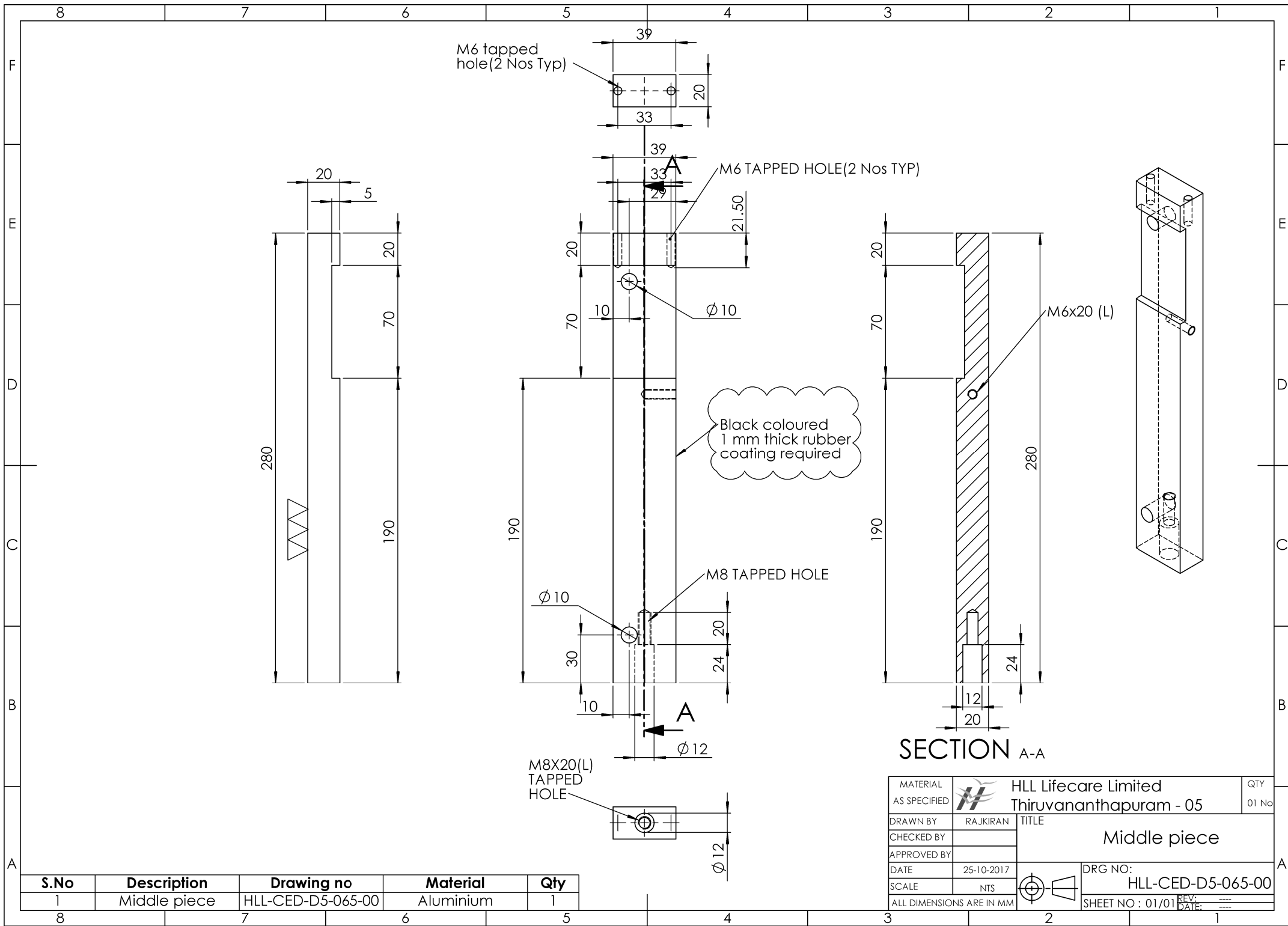

S.No	Description	Drawing no	Material	Qty
1	Middle piece	HLL-CED-D5-065-00	Aluminium	1

MATERIAL AS SPECIFIED	HLL Lifecare Limited Thiruvananthapuram - 05	QTY 01 No
DRAWN BY RAJKIRAN	TITLE Middle piece	
CHECKED BY		
APPROVED BY		
DATE 25-10-2017	DRG NO: HLL-CED-D5-065-00	
SCALE NTS	SHEET NO : 01/01	
ALL DIMENSIONS ARE IN MM	REV: _____ DATE: _____	

4 3 2 1

F

F

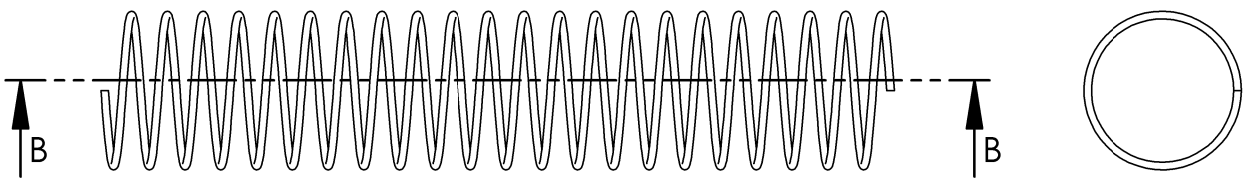

Spring

E

E

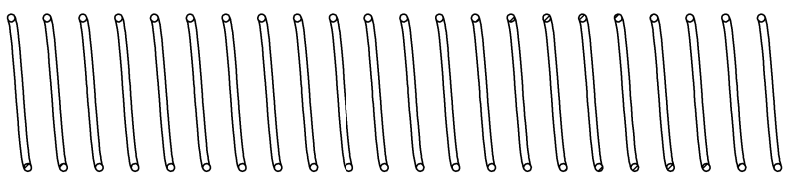

SECTION B-B
SCALE 4 : 1

D

D

ITEM NO.	PART NUMBER	DESCRIPTION	QTY
1	Spring	HLL-CED-D5-071-00	1

C

C

S.No	Description	Specification
1	Wire dia	0.25 mm
2	No. turns	22
3	Diameter	5 mm
4	Length of the wire	26 mm
5	Spring material	Chrome vanadidum ASTM A 231 spring wire which have a composition of C 0.48 - 0.53% Cr 0.80 - 1.10% V 0.15 - min%

B

B

Weight of the Component : g (approx.)

A

A

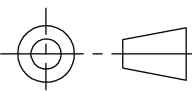
MATERIAL AS SPECIFIED		HLL Lifecare Limited Thiruvananthapuram - 05	QTY 01 No
DRAWN BY	RAJKIRAN	TITLE Spring	
CHECKED BY	SARATH		
APPROVED BY	KRK		
DATE	17.01.2017	DRG NO:	HLL-CED-D5-071-00
SCALE	NTS	SHEET NO:	01/01
ALL DIMENSIONS ARE IN MM			REV: DATE:

4 3 2 1

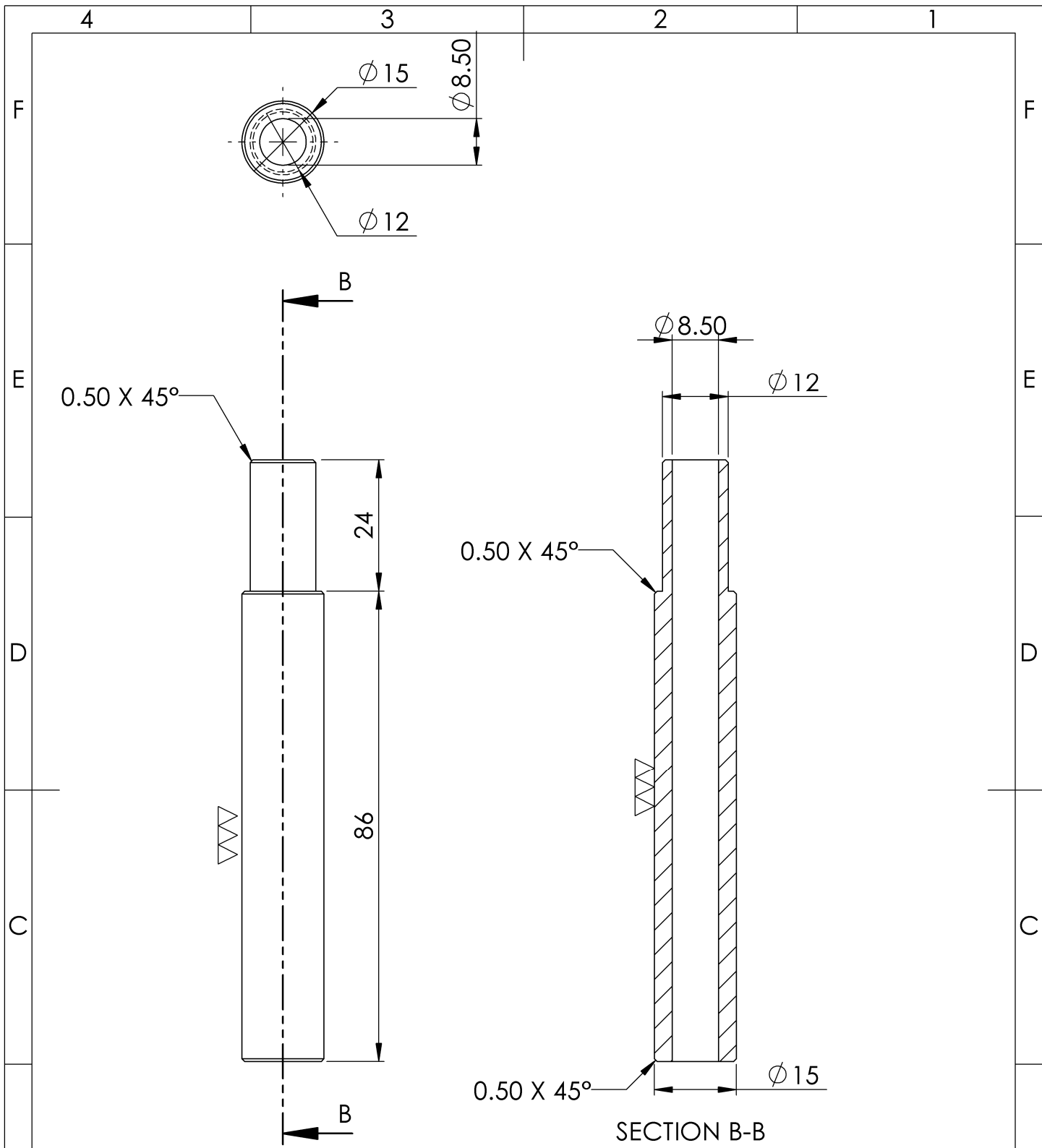

S.No	Description	Drawing No	Material	Qty
1	Shaft for shaft support fixing	HLL-CED-D5-068-00	SS 304	1

Weight of the Component : g (approx.)

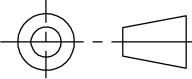
MATERIAL AS SPECIFIED		HLL Lifecare Limited Thiruvananthapuram - 05	QTY 01 No
DRAWN BY	RAJKIRAN	TITLE Shaft for flap support fixing	
CHECKED BY	SARATH		
APPROVED BY	KRK		
DATE	17.01.2017	DRG NO:	HLL-CED-D5-068-00
SCALE	NTS	SHEET NO:	01/01
ALL DIMENSIONS ARE IN MM			REV: DATE:

4

3

2

1

F

F

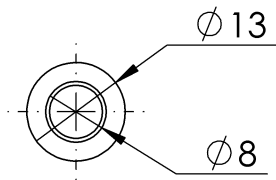

E

E

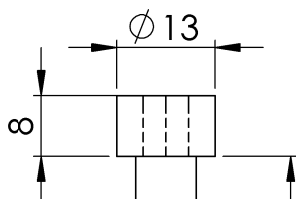

D

D

100

C

C

M8 THREADED REGION

30

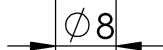

Weight of the Component
: g (approx.)

B

B

ITEM NO.	PART NUMBER	DESCRIPTION	QTY.
1	M8x130(L) SHD BOLT	HLL-CED-D5-064-00	1

A

A

MATERIAL
AS SPECIFIED



HLL Lifecare Limited
Thiruvananthapuram - 05

QTY
01 No

DRAWN BY RAJKIRAN

CHECKED BY SARATH

APPROVED BY KRK

DATE 17.01.2017

SCALE NTS

ALL DIMENSIONS ARE IN MM

TITLE

M8X130(L) SHD BOLT FOR TESTING FLAP

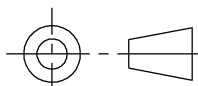

DRG NO: HLL-CED-D5-064-00

SHEET NO: 01/01

REV:
DATE:

4

3

2

1

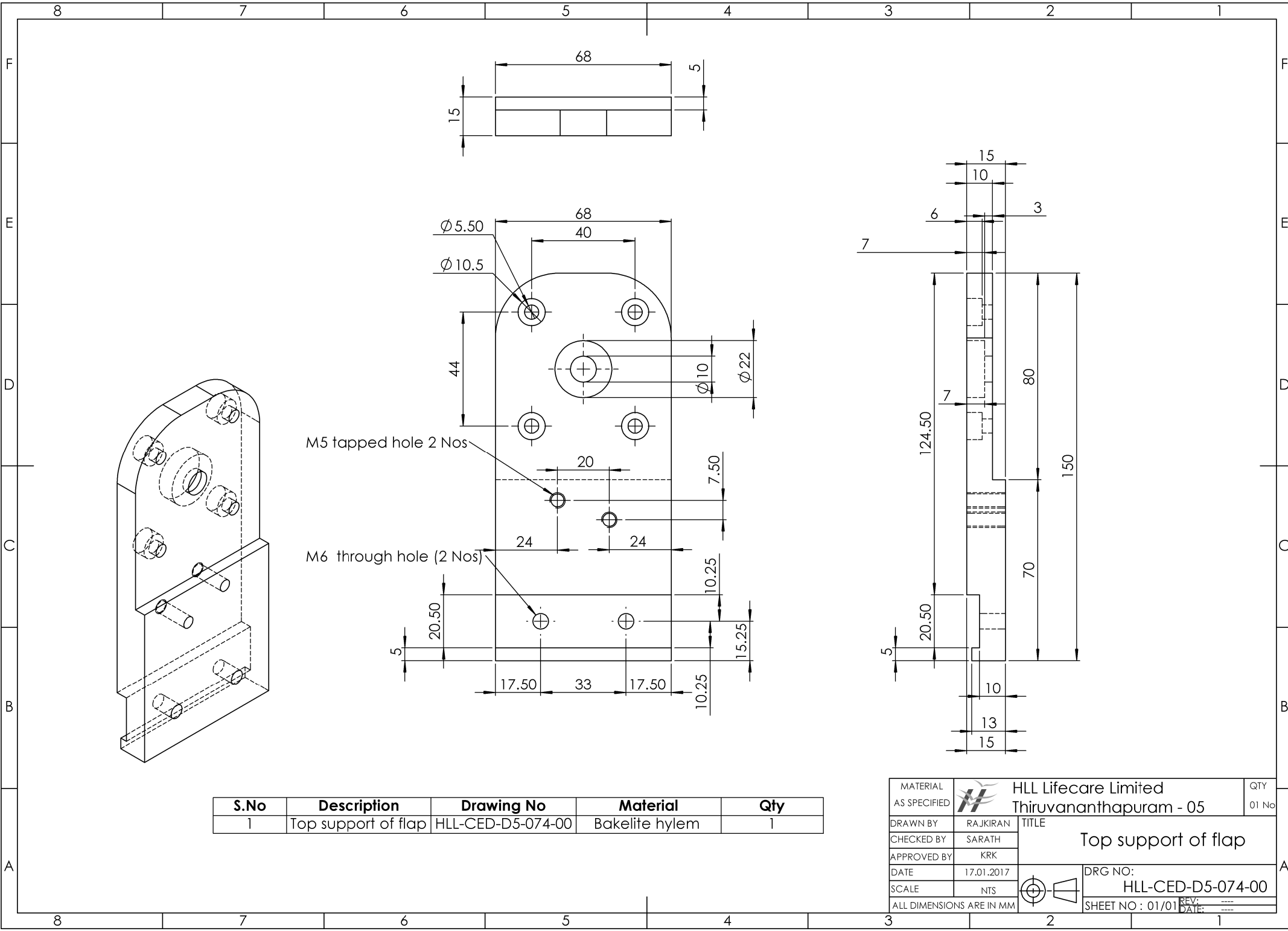

M5 tapped hole 2 Nos

M6 through hole (2 Nos)

S.No	Description	Drawing No	Material	Qty
1	Top support of flap	HLL-CED-D5-074-00	Bakelite hylem	1

MATERIAL AS SPECIFIED		HLL Lifecare Limited Thiruvananthapuram - 05	QTY 01 No
DRAWN BY	RAJKIRAN	TITLE Top support of flap	
CHECKED BY	SARATH		
APPROVED BY	KRK		
DATE	17.01.2017	DRG NO: HLL-CED-D5-074-00	
SCALE	NTS	SHEET NO : 01/01	
ALL DIMENSIONS ARE IN MM		REV: _____ DATE: _____	

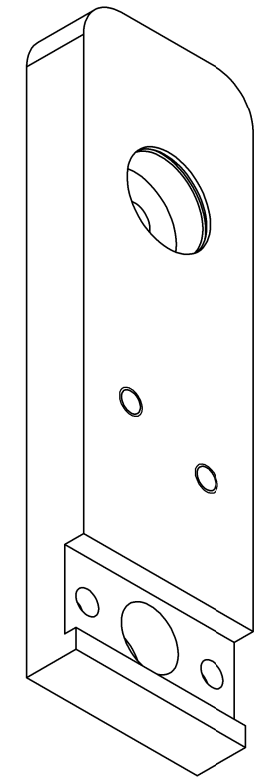
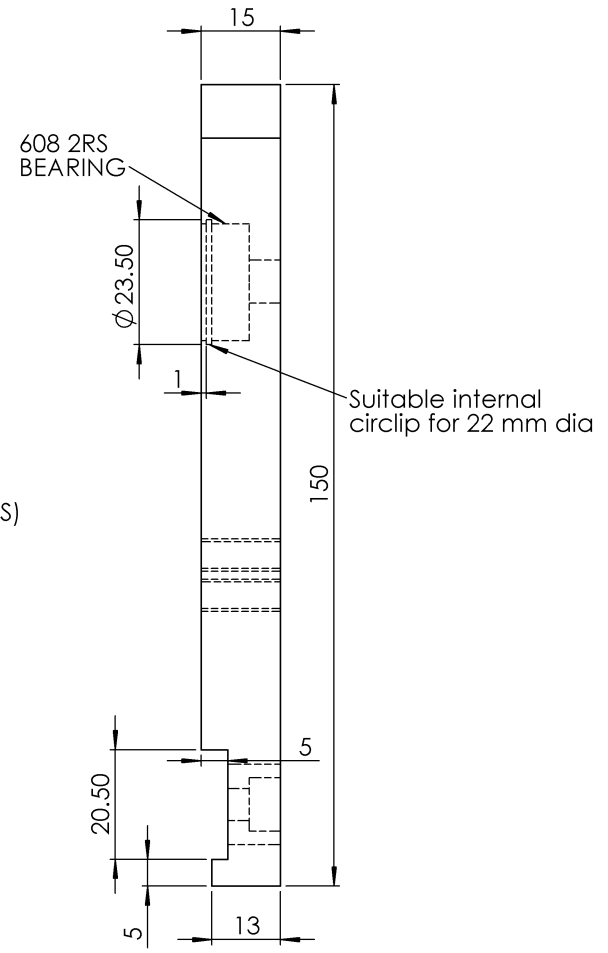
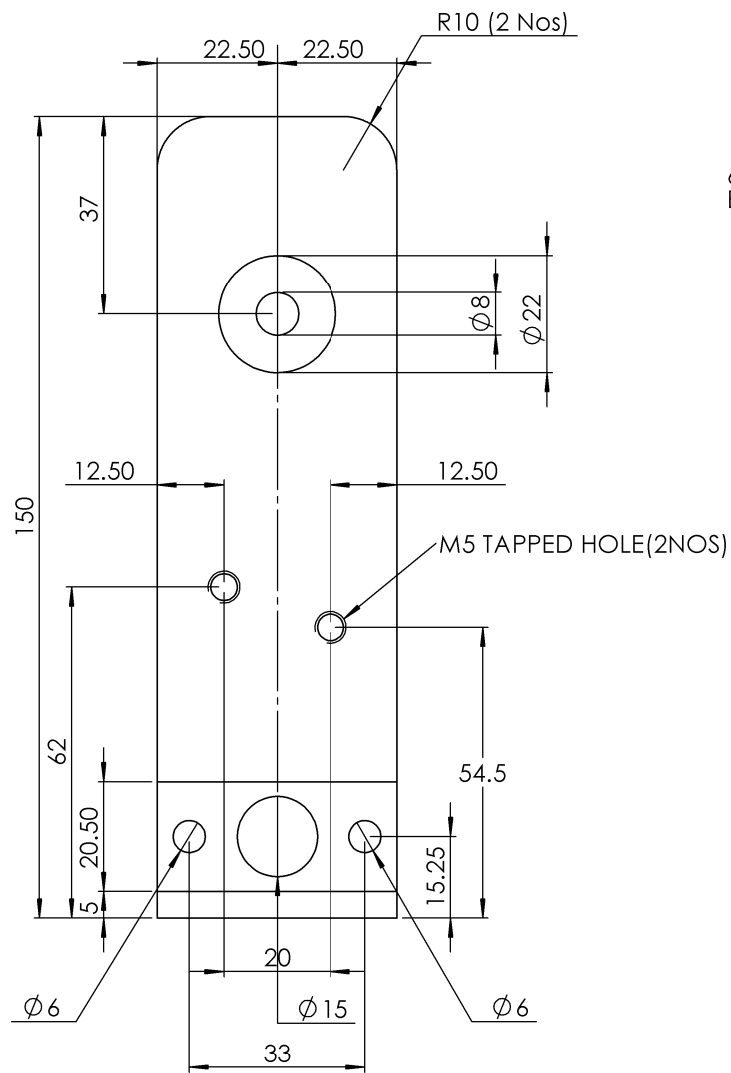

S.No	Description	Drawing No	Material	Qty
1	Bottom support of flap	HLL-CED-D5-057-00	Hylem	1

MATERIAL AS SPECIFIED	 HLL Lifecare Limited Thiruvananthapuram - 05	QTY 01 No
DRAWN BY	RAJKIRAN	TITLE
CHECKED BY	SARATH	Bottom support of flap
APPROVED BY	KRK	
DATE	17.01.2017	DRG NO:
SCALE	NTS	HLL-CED-D5-057-00
ALL DIMENSIONS ARE IN MM		SHEET NO : 01/01
		REV: --- DATE: ---

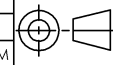

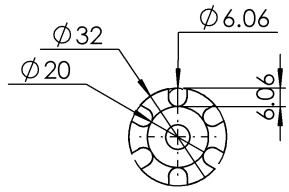

S.No	Description	Drawing No	Material	Qty
1	Flap fixing roller	HLL-CED-D5-061-00	Nylon	1

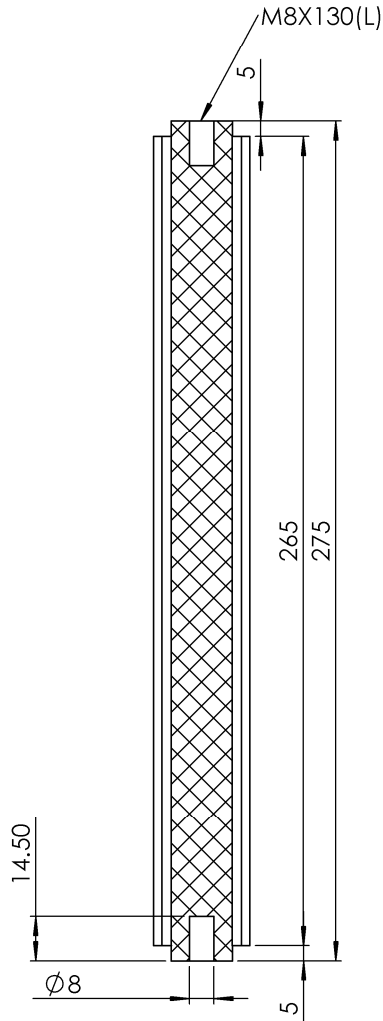
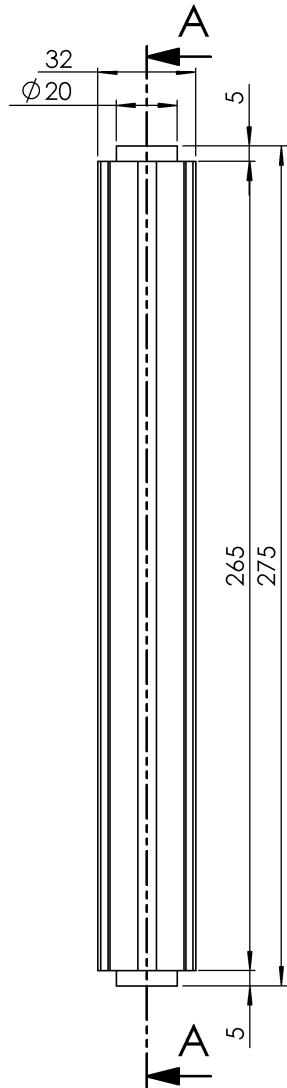

SECTION A-A
SCALE 1 : 1.75

MATERIAL AS SPECIFIED	 HLL Lifecare Limited Thiruvananthapuram - 05	QTY 01 No
DRAWN BY	RAJKIRAN	TITLE Flap fixing roller
CHECKED BY		
APPROVED BY		
DATE	25-10-2015	DRG NO: HLL-CED-D5-061-00
SCALE	NTS	SHEET NO : 01/01
ALL DIMENSIONS ARE IN MM		REV: _____ DATE: _____

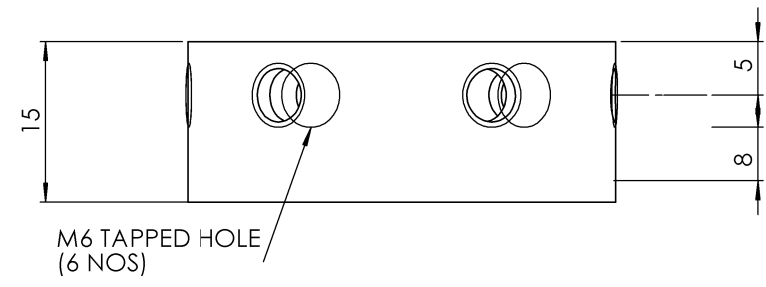
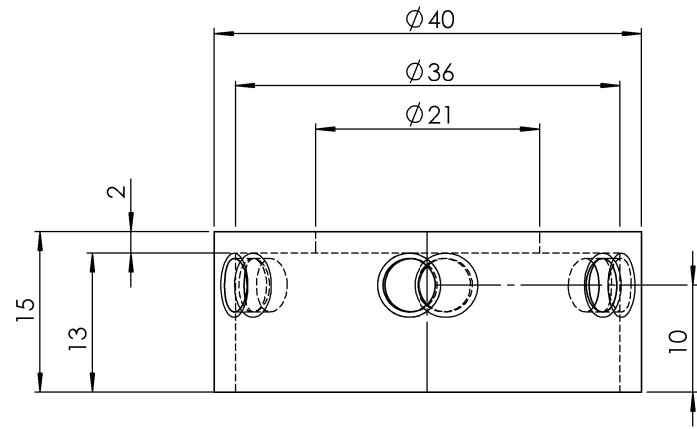
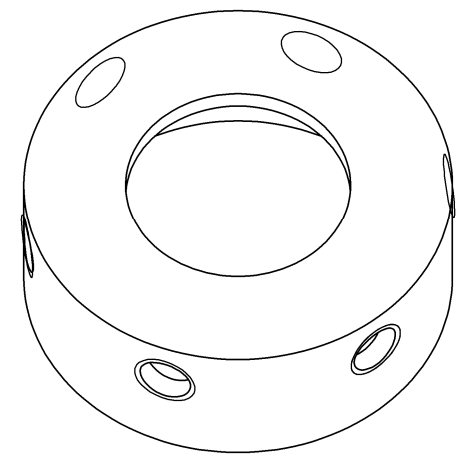
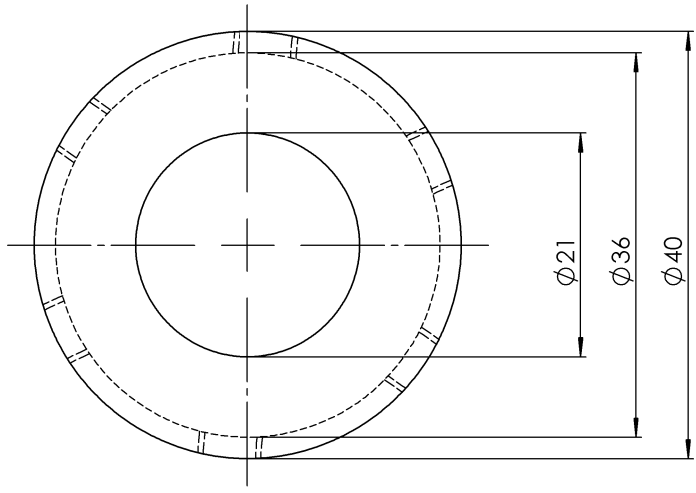

S.No	Description	Drawing No	Material	Qty
1	Collar for testing flap	HLL-CED-D5-060-00	Brass	2
2	M6 grub screw		SS 304	6

MATERIAL AS SPECIFIED		HLL Lifecare Limited Thiruvananthapuram - 05	QTY 01 No
DRAWN BY	RAJKIRAN	TITLE Collar for testing flap	
CHECKED BY	SARATH		
APPROVED BY	KRK	DRG NO: HLL-CED-D5-060-00	
DATE	17.01.2017		
SCALE	NTS	SHEET NO : 01/01 REV: --- DATE: ---	
ALL DIMENSIONS ARE IN MM			

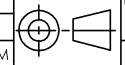

4

3

2

1

F

F

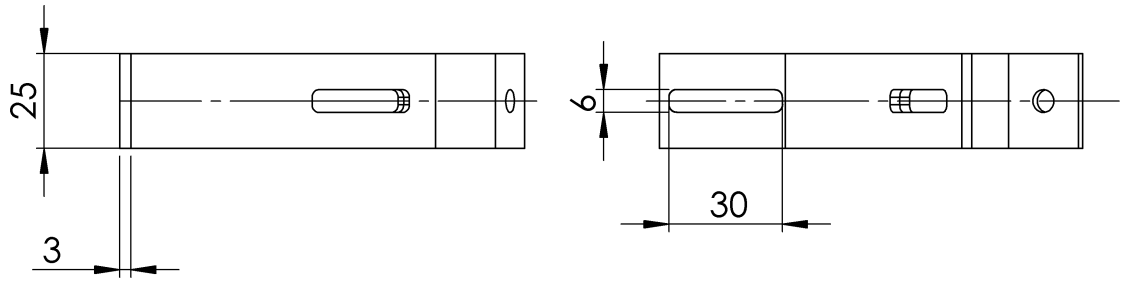

E

E

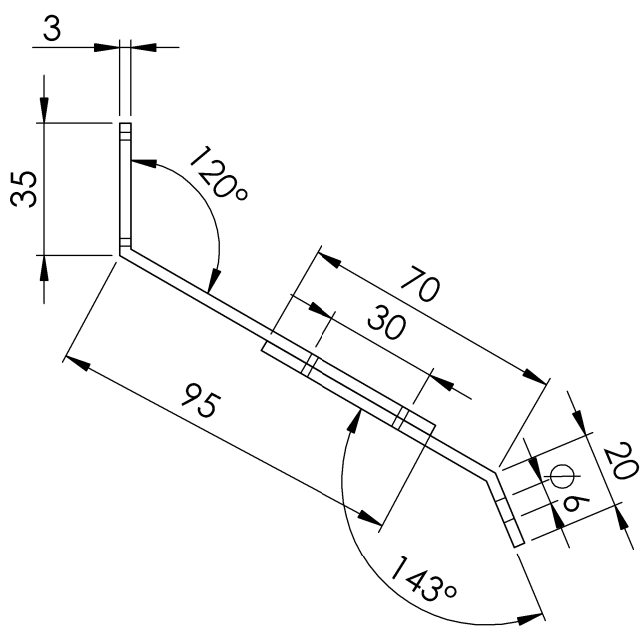

D

D

C

C

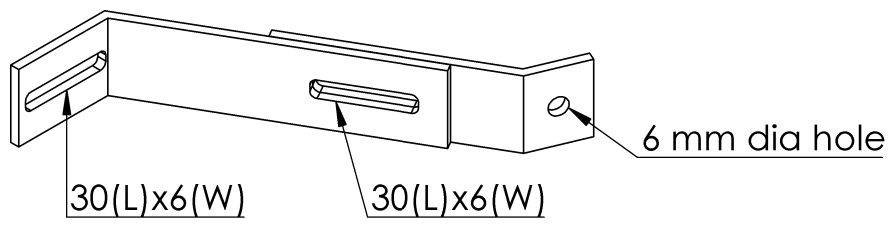

S.No	Description	Drawing No	Material	Qty
1	Testing flap stiffner	HLL-CED-D5-072-00	SS 304	1

B

B

Weight of the Component : g (approx.)

A

A

MATERIAL AS SPECIFIED



HLL Lifecare Limited
Thiruvananthapuram - 05

QTY
01 No

DRAWN BY RAJKIRAN
 CHECKED BY
 APPROVED BY

TITLE
Testing flap stiffner

DATE 26-10-2017
 SCALE NTS
 ALL DIMENSIONS ARE IN MM

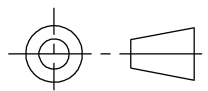

DRG NO: HLL-CED-D5-072-00

SHEET NO: 01/01

REV:
DATE:

4

3

2

1

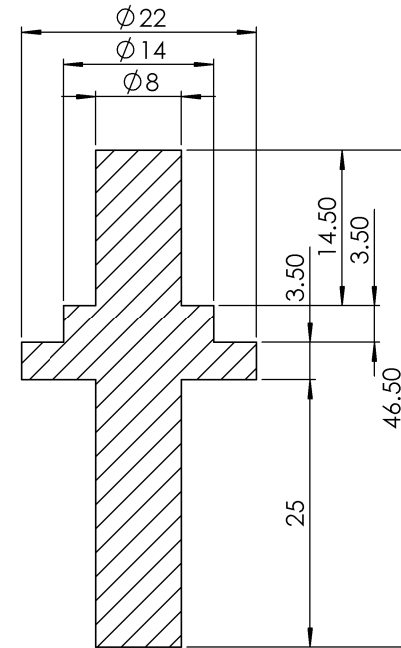
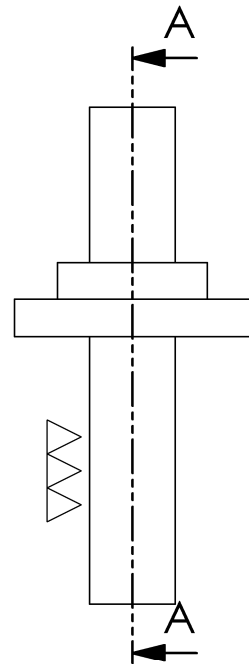
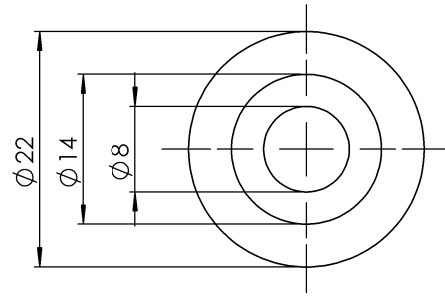

SECTION A-A

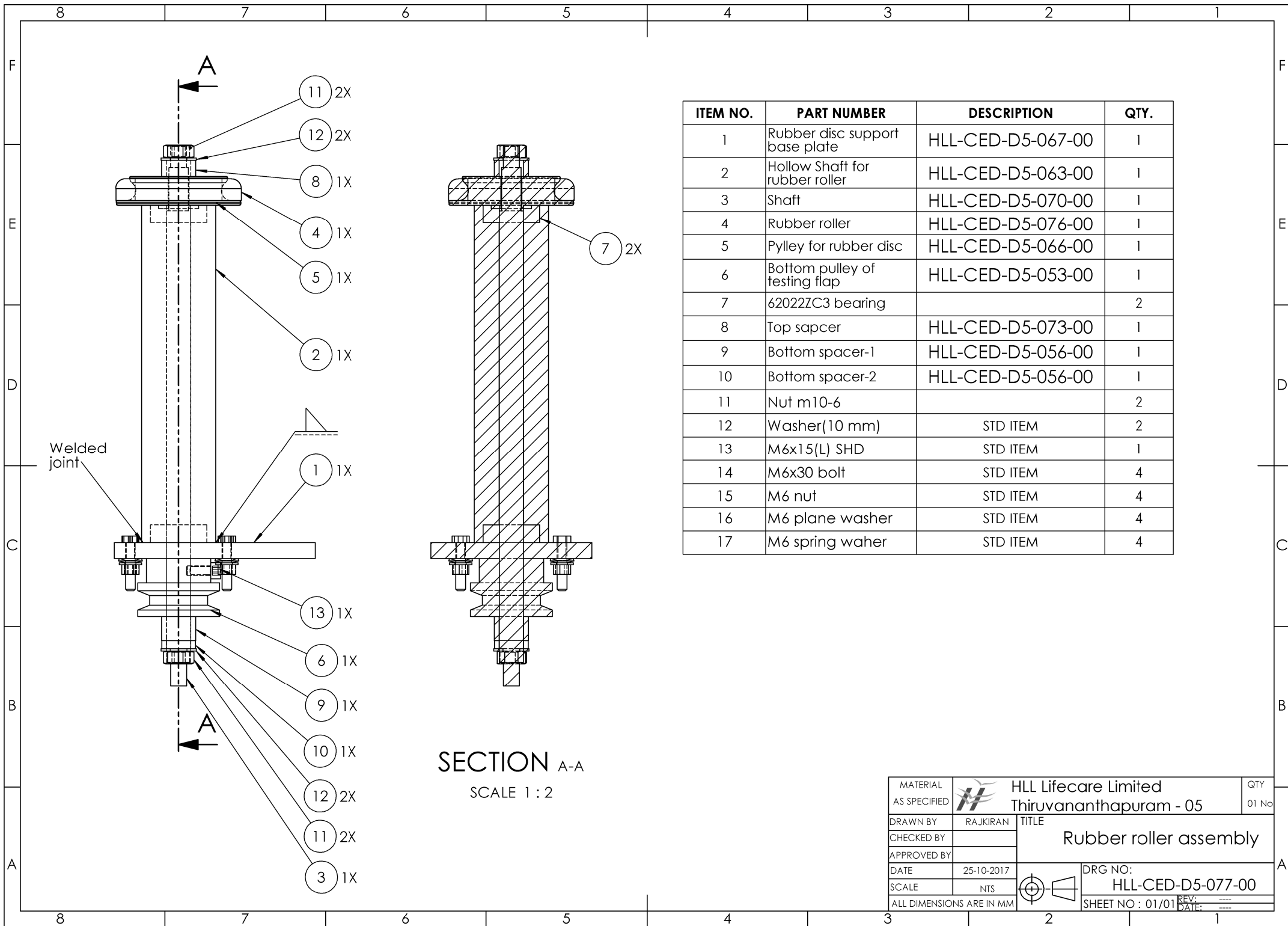

ITEM NO.	PART NUMBER	DESCRIPTION	QTY.
1	Bottom support anchor of testing flap stem	HLL-CED-D5-091-00	1

MATERIAL AS SPECIFIED	HLL Lifecare Limited Thiruvananthapuram - 05	QTY. 01 No
DRAWN BY	RAJKIRAN	TITLE Bottom support anchor of testing flap stem
CHECKED BY		DRG NO: HLL-CED-D5-091-00
APPROVED BY		SHEET NO : 01/01
DATE	26-10-2017	REV: _____ DATE: _____
SCALE	NTS	
ALL DIMENSIONS ARE IN MM		



ITEM NO.	PART NUMBER	DESCRIPTION	QTY.
1	Rubber disc support base plate	HLL-CED-D5-067-00	1
2	Hollow Shaft for rubber roller	HLL-CED-D5-063-00	1
3	Shaft	HLL-CED-D5-070-00	1
4	Rubber roller	HLL-CED-D5-076-00	1
5	Pylley for rubber disc	HLL-CED-D5-066-00	1
6	Bottom pulley of testing flap	HLL-CED-D5-053-00	1
7	62022ZC3 bearing		2
8	Top sapcer	HLL-CED-D5-073-00	1
9	Bottom spacer-1	HLL-CED-D5-056-00	1
10	Bottom spacer-2	HLL-CED-D5-056-00	1
11	Nut m10-6		2
12	Washer(10 mm)	STD ITEM	2
13	M6x15(L) SHD	STD ITEM	1
14	M6x30 bolt	STD ITEM	4
15	M6 nut	STD ITEM	4
16	M6 plane washer	STD ITEM	4
17	M6 spring waher	STD ITEM	4

SECTION A-A
SCALE 1 : 2

MATERIAL AS SPECIFIED	 HLL Lifecare Limited Thiruvananthapuram - 05	QTY
DRAWN BY		01 No
CHECKED BY	TITLE Rubber roller assembly	
APPROVED BY	DRG NO: HLL-CED-D5-077-00	
DATE	25-10-2017	REV: ----
SCALE	NTS	DATE: ----
ALL DIMENSIONS ARE IN MM		 SHEET NO : 01/01

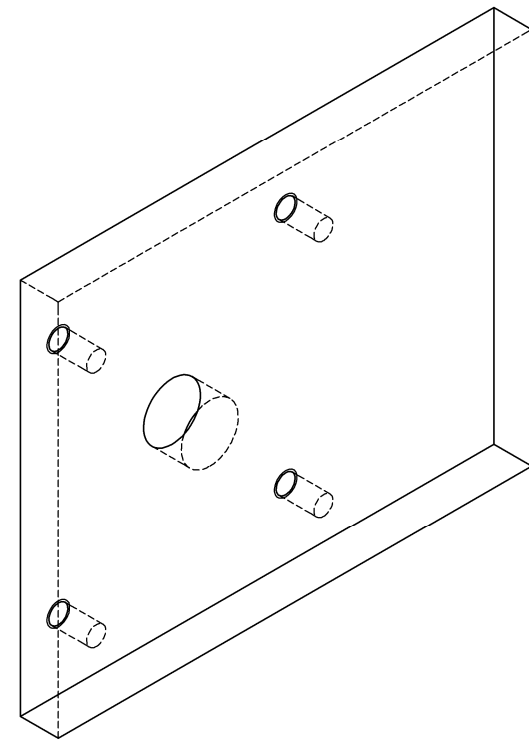
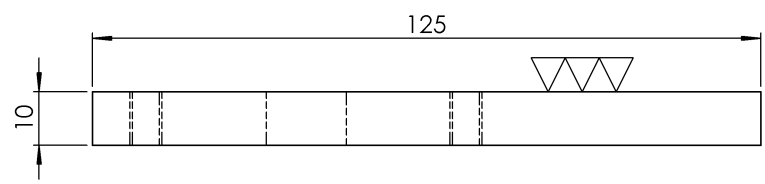
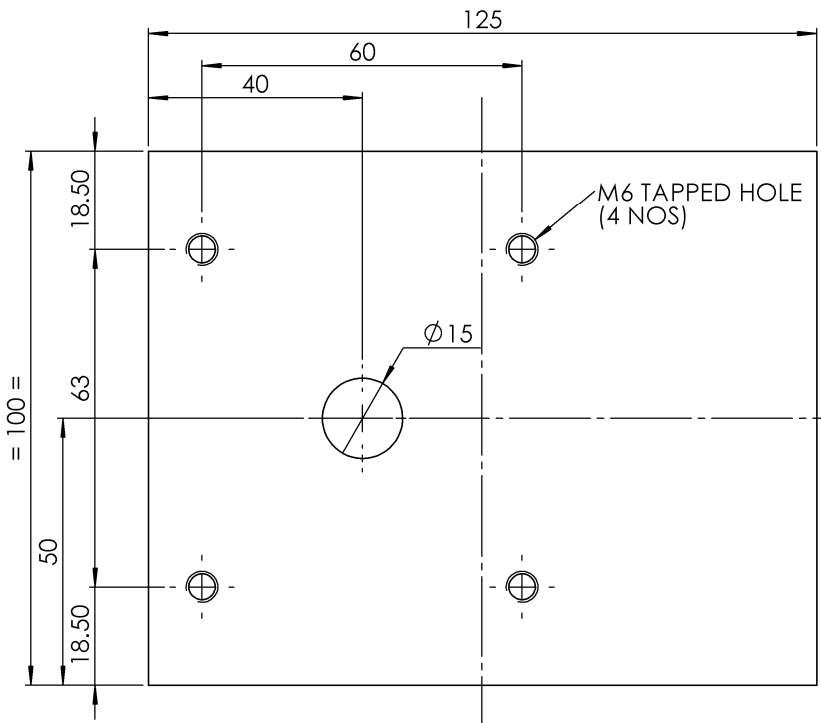
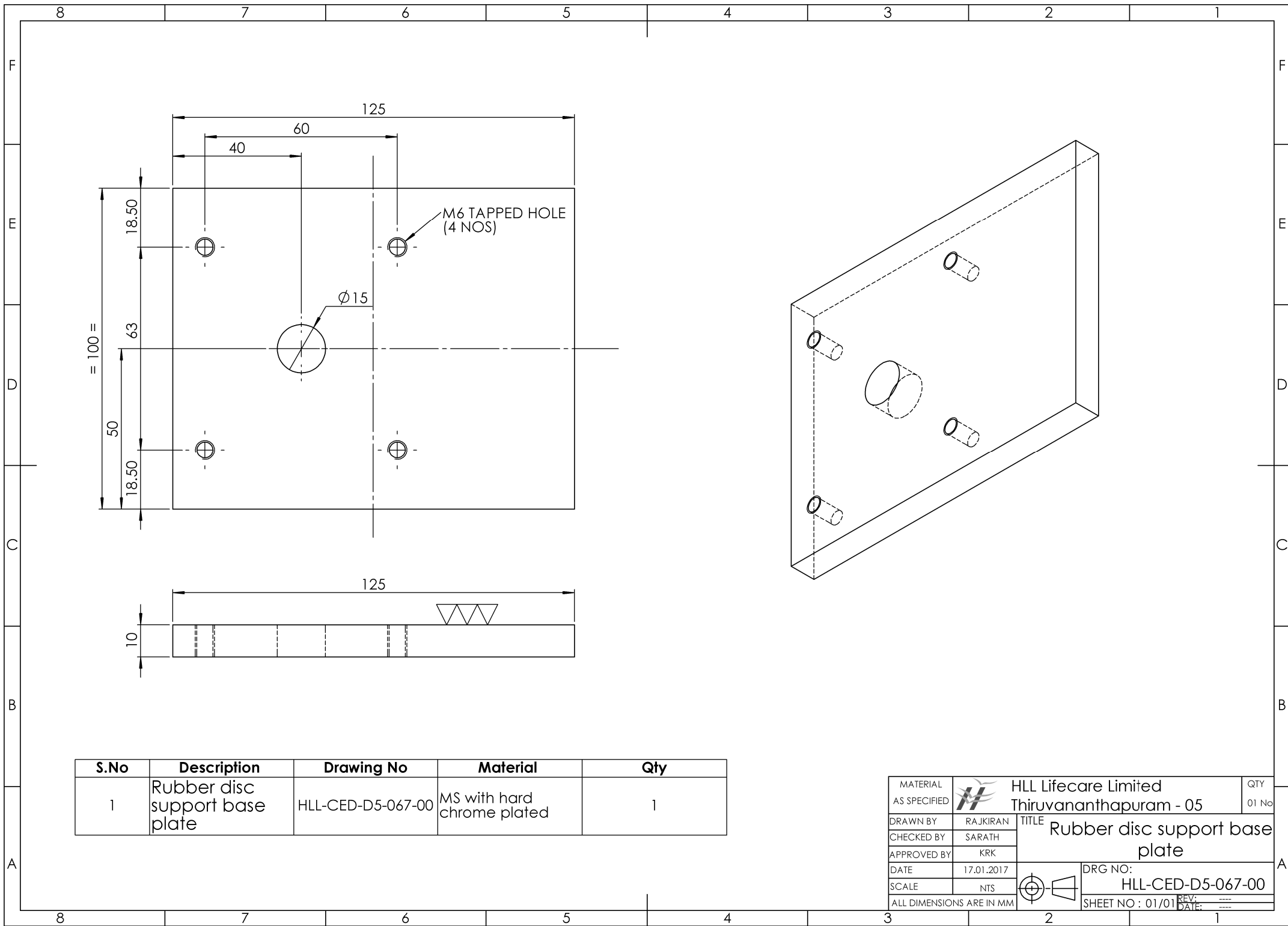

S.No	Description	Drawing No	Material	Qty
1	Rubber disc support base plate	HLL-CED-D5-067-00	MS with hard chrome plated	1

MATERIAL AS SPECIFIED	 HLL Lifecare Limited Thiruvananthapuram - 05	QTY 01 No
DRAWN BY	RAJKIRAN	TITLE Rubber disc support base plate
CHECKED BY	SARATH	
APPROVED BY	KRK	
DATE	17.01.2017	DRG NO: HLL-CED-D5-067-00
SCALE	NTS	SHEET NO : 01/01
ALL DIMENSIONS ARE IN MM		REV: _____ DATE: _____

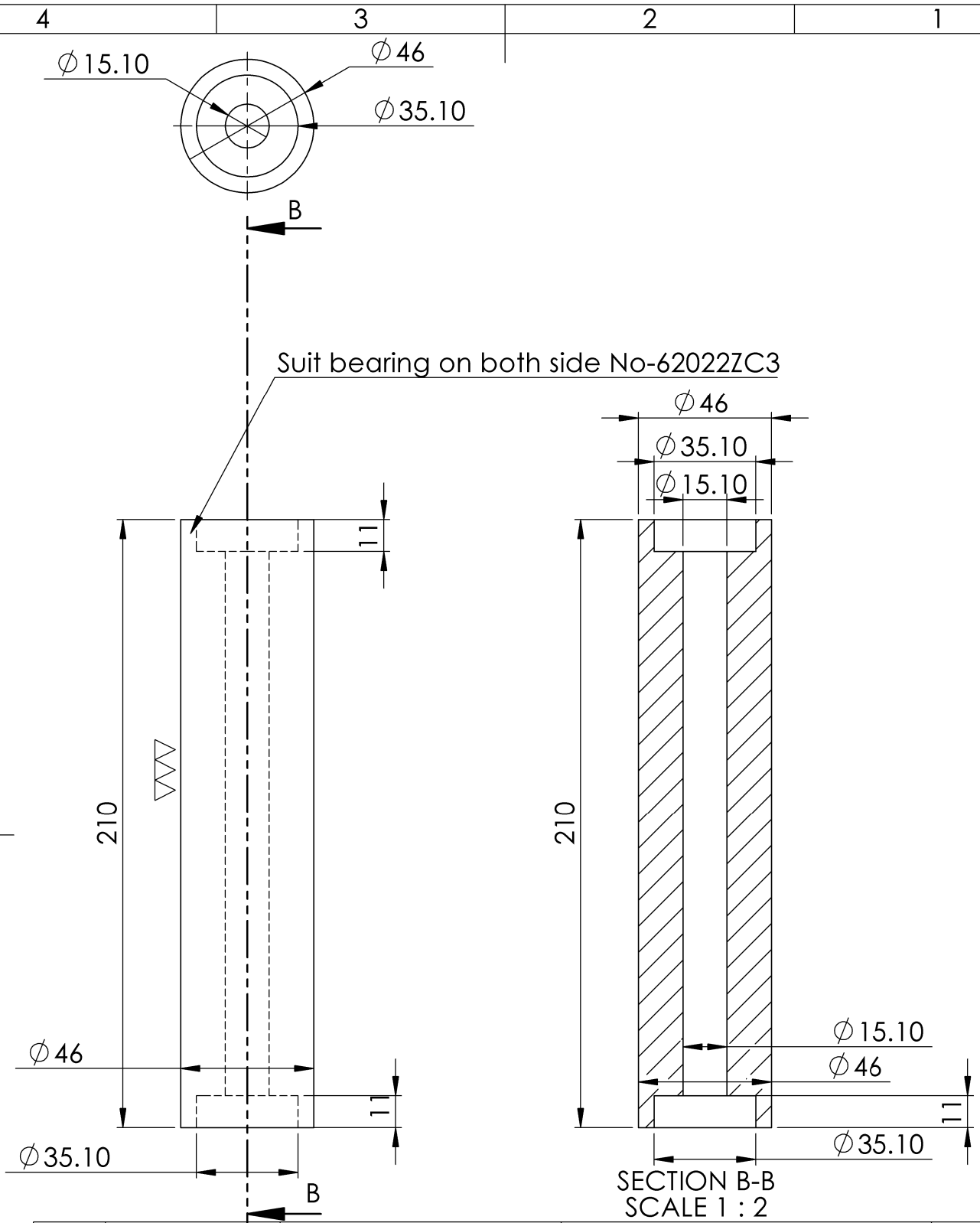

S.No	Description	Drawing no	Material	Qty
1	Hollow shaft	HLL-CED-D5-063-00	MS WITH POWDER COATED	1

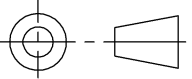
MATERIAL SS304		HLL Lifecare Limited Thiruvananthapuram - 05	QTY 01 No
DRAWN BY RAJKIRAN	TITLE Hollow shaft for rubber roller		
CHECKED BY			
APPROVED BY			
DATE 26-10-2017		DRG NO: HLL-CED-D5-063-00	
SCALE NTS		SHEET NO: 01/01	
ALL DIMENSIONS ARE IN MM		REV:	DATE:

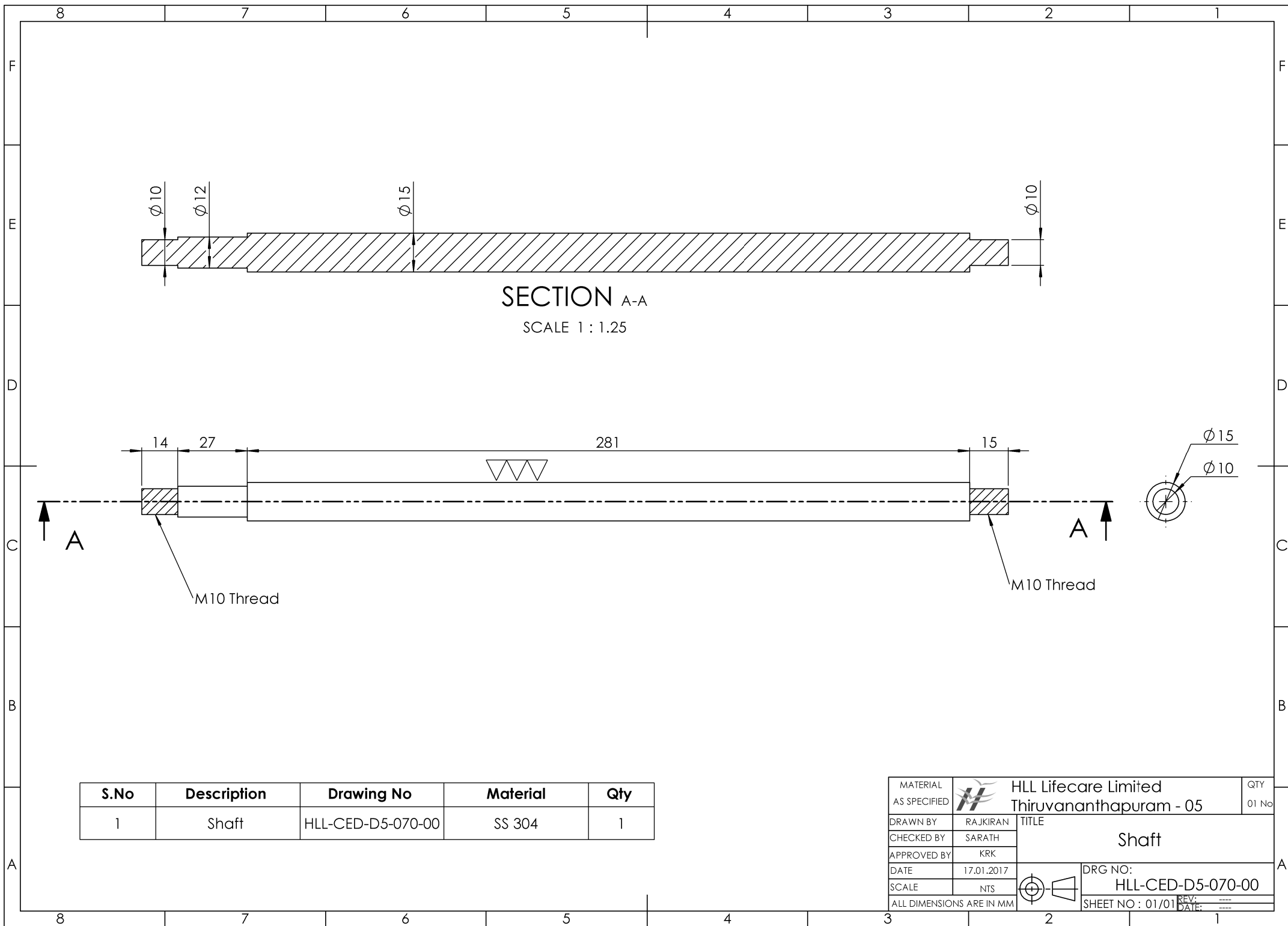

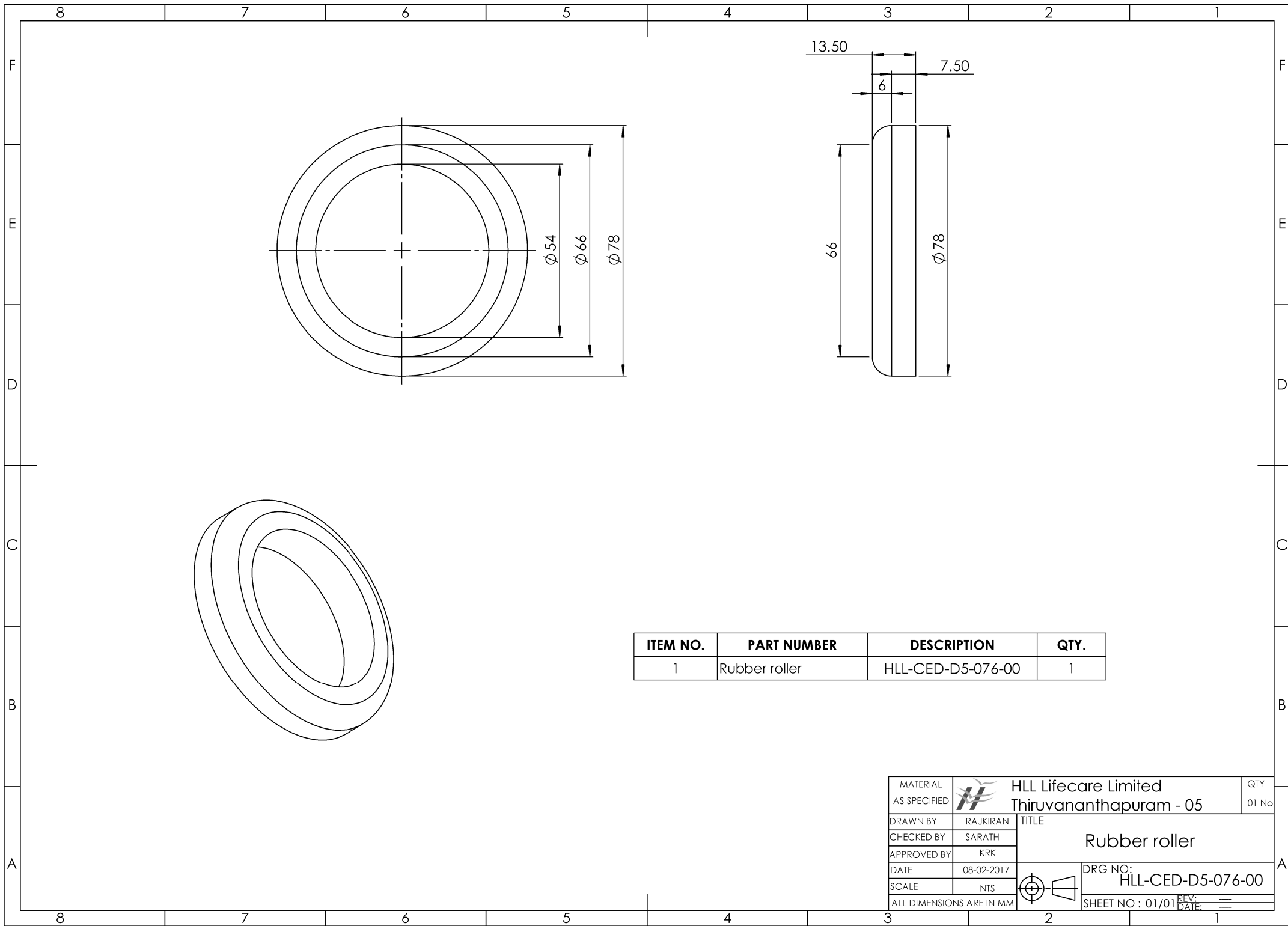

ITEM NO.	PART NUMBER	DESCRIPTION	QTY.
1	Rubber roller	HLL-CED-D5-076-00	1

MATERIAL AS SPECIFIED	 HLL Lifecare Limited Thiruvananthapuram - 05	QTY 01 No
DRAWN BY	RAJKIRAN	TITLE Rubber roller
CHECKED BY	SARATH	
APPROVED BY	KRK	
DATE	08-02-2017	DRG NO: HLL-CED-D5-076-00
SCALE	NTS	SHEET NO : 01/01
ALL DIMENSIONS ARE IN MM		REV: _____ DATE: _____

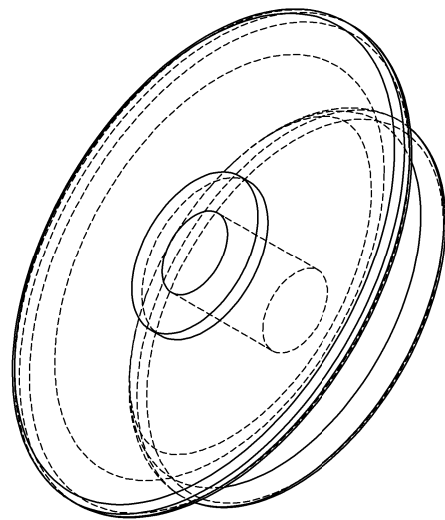
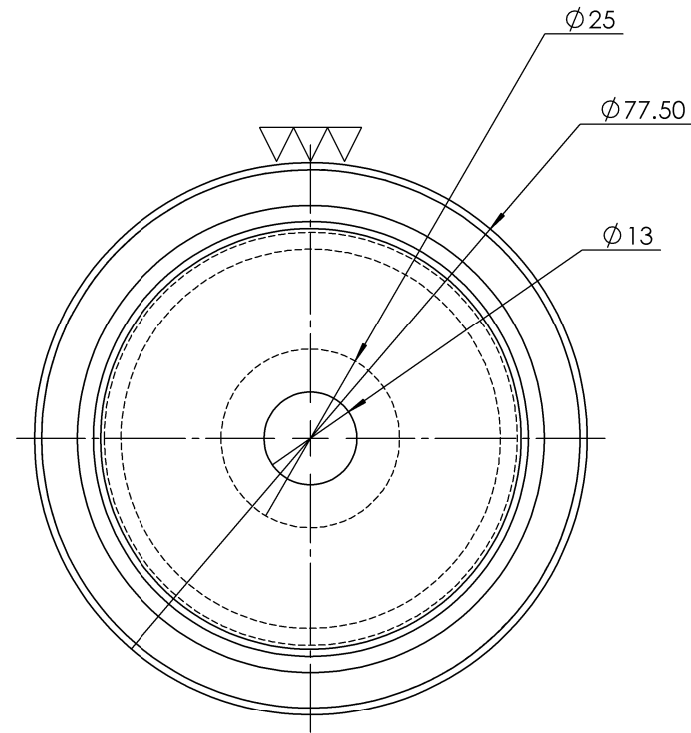
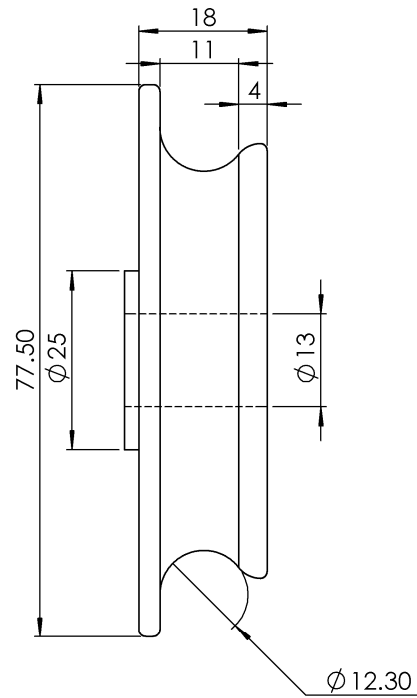

S.No	Description	Drawing No	Material	Qty
1	Pulley for rubber disc	HLL-CED-D5-066-00	Aluminium (Hard chrome plated)	1

MATERIAL AS SPECIFIED	 HLL Lifecare Limited Thiruvananthapuram - 05	QTY 01 No
DRAWN BY	RAJKIRAN	TITLE Pulley for rubber disc
CHECKED BY	SARATH	
APPROVED BY	KRK	
DATE	17.01.2017	DRG NO: HLL-CED-D5-066-00
SCALE	NTS	SHEET NO : 01/01
ALL DIMENSIONS ARE IN MM		REV: _____ DATE: _____

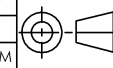

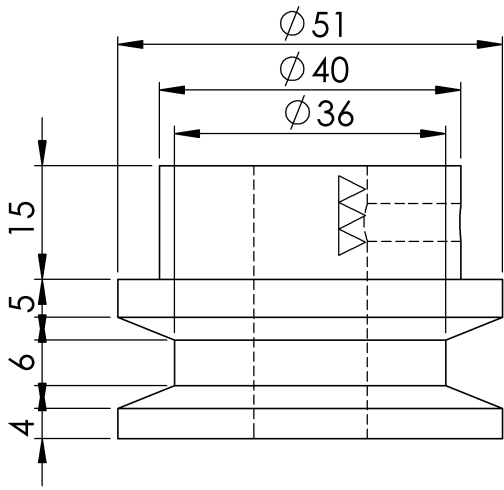

M6 tapped hole

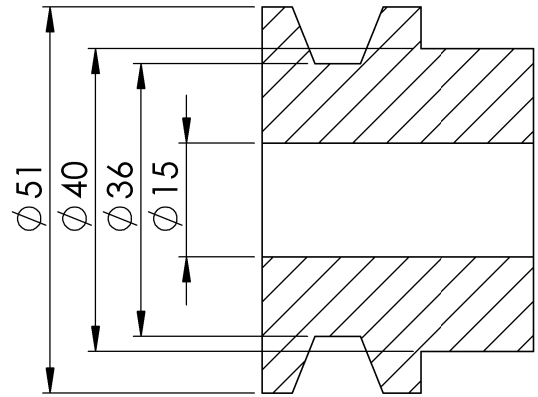
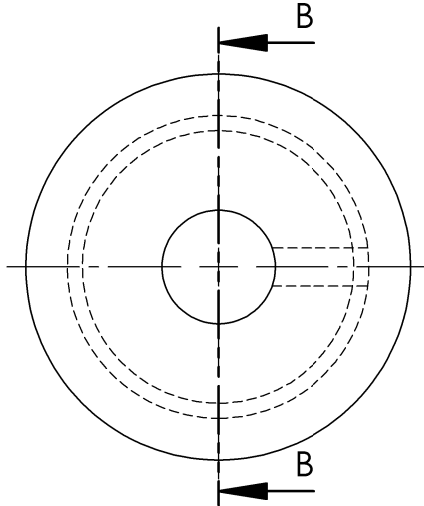
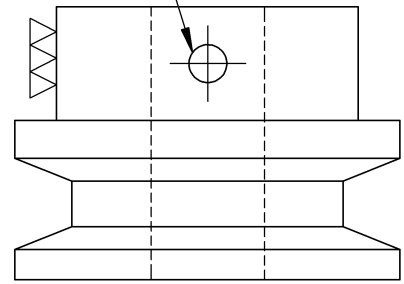

SECTION B-B

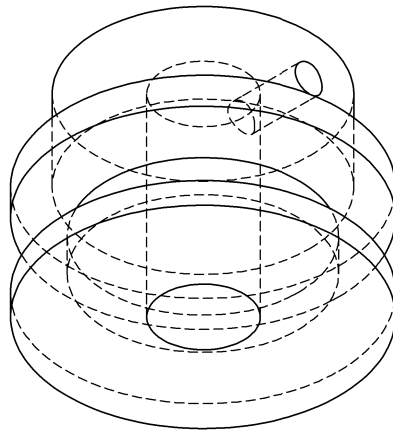

S.No	Description	Drawing No	Material	Qty
1	Bottom pulley	HLL-CED-D5-053-00	MS with Hard chrome plated	1

Weight of the Component : g (approx.)

MATERIAL AS SPECIFIED



HLL Lifecare Limited
Thiruvananthapuram - 05

QTY
01 No

DRAWN BY RAJKIRAN
CHECKED BY SARATH
APPROVED BY KRK

TITLE

Bottom pulley of testing flap

DATE 17.01.2017

SCALE NTS

ALL DIMENSIONS ARE IN MM

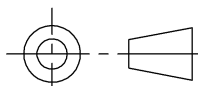

DRG NO: HLL-CED-D5-053-00

SHEET NO: 01/01

REV:
DATE:

4

3

2

1

4

3

2

1

F

F

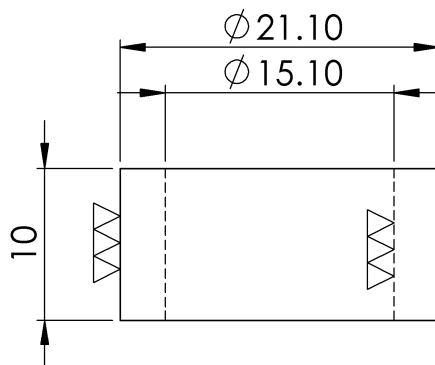

E

E

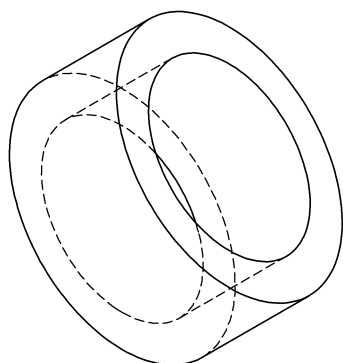

D

D

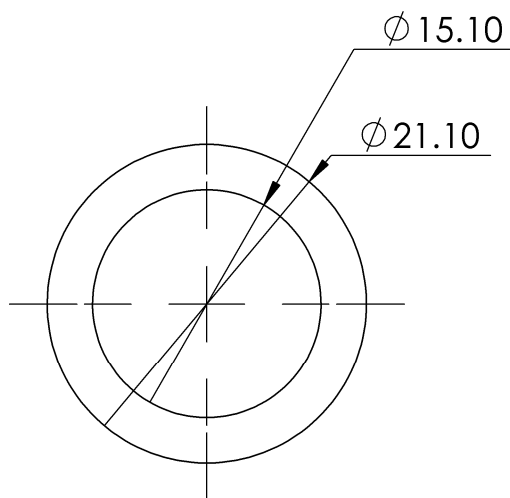

C

C

S.No	Description	Drawing No	Material	Qty
1	Top spacer	HLL-CED-D5-073-00	SS 304	1

B

B

Weight of the Component : g (approx.)

MATERIAL
AS SPECIFIED



HLL Lifecare Limited
Thiruvananthapuram - 05

QTY
01 No

DRAWN BY RAJKIRAN
CHECKED BY SARATH
APPROVED BY KRK

TITLE

Top spacer

DATE 17.01.2017

SCALE NTS

ALL DIMENSIONS ARE IN MM

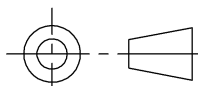

DRG NO: HLL-CED-D5-073-00

SHEET NO: 01/01

REV:
DATE:

A

A

4

3

2

1

4

3

2

1

F

F

E

E

D

D

C

C

B

B

A

A

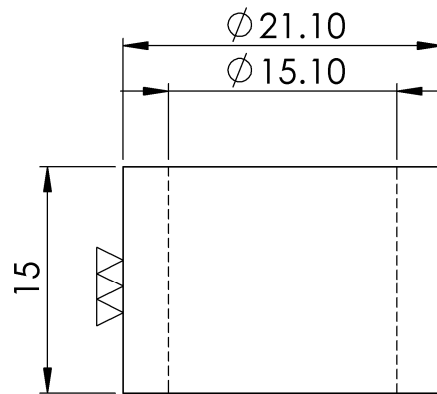
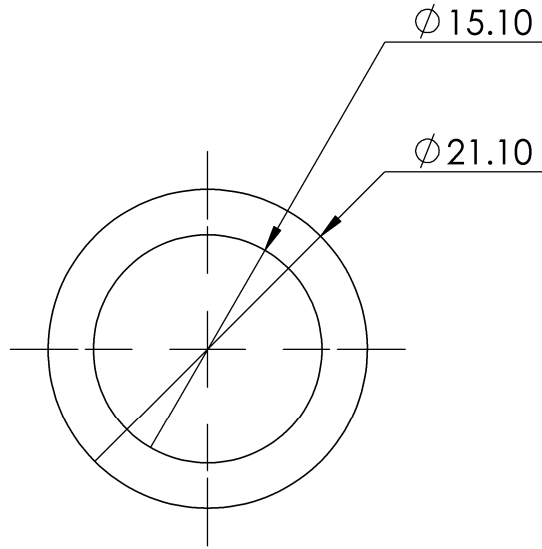
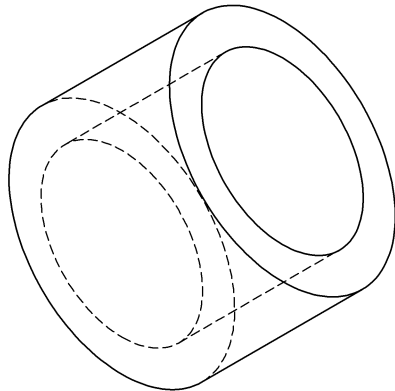

S.No	Description	Drawing No	Material	Qty
1	Bottom spacer-1	HLL-CED-D5-055-00	SS304	1

Weight of the Component : g (approx.)

MATERIAL AS SPECIFIED		HLL Lifecare Limited Thiruvananthapuram - 05	QTY 01 No
-----------------------	---	---	--------------

DRAWN BY	RAJKIRAN	TITLE Bottom spacer-1
CHECKED BY	SARATH	
APPROVED BY	KRK	

DATE	17.01.2017	DRG NO:	HLL-CED-D5-055-00
------	------------	---------	-------------------

SCALE	NTS	SHEET NO: 01/01	REV:
-------	-----	-----------------	------

ALL DIMENSIONS ARE IN MM		DATE:	
--------------------------	--	-------	--

4

3

2

1

4

3

2

1

F

F

E

E

D

D

C

C

B

B

A

A

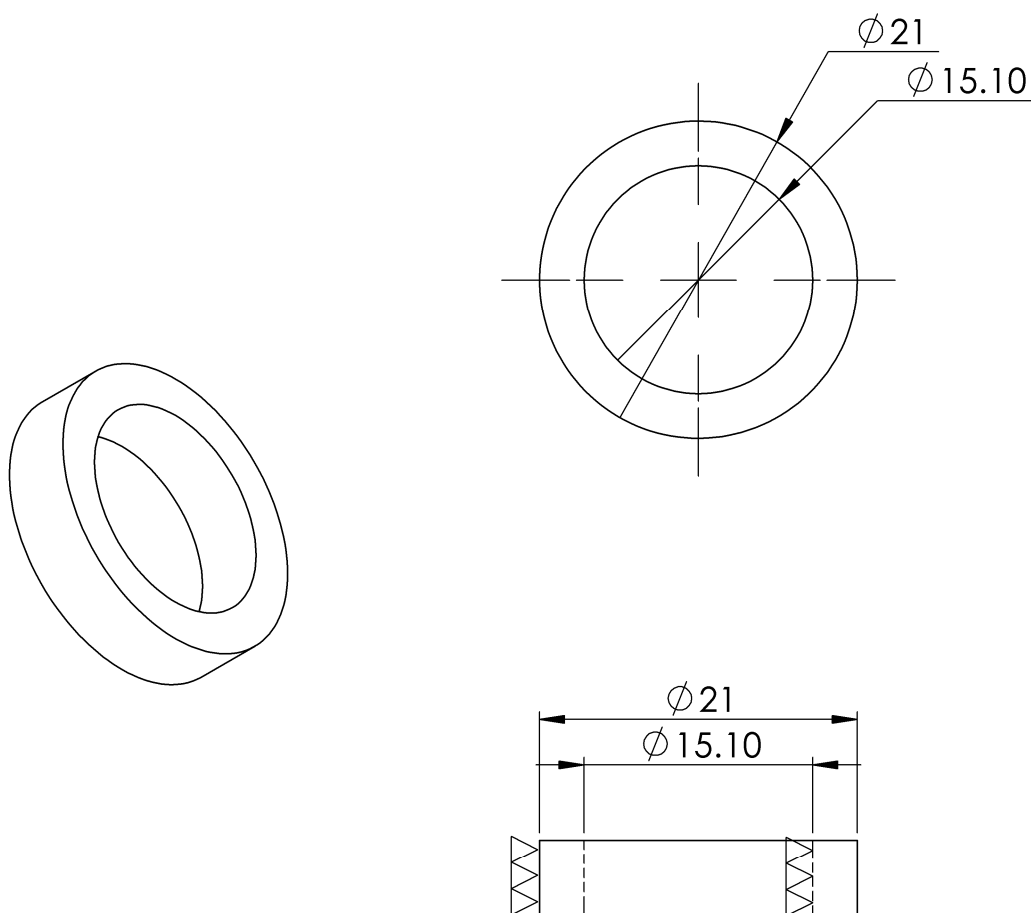

S.No	Description	Drawing No	Material	Qty
1	Bottom spacer-2	HLL-CED-D5-056-00	SS 304	1

Weight of the Component : g (approx.)

MATERIAL
AS SPECIFIED



HLL Lifecare Limited
Thiruvananthapuram - 05

QTY
01 No

DRAWN BY RAJKIRAN
CHECKED BY SARATH
APPROVED BY KRK

TITLE

Bottom spacer-2

DATE 17.01.017

SCALE NTS

ALL DIMENSIONS ARE IN MM

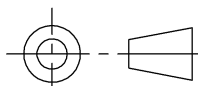

DRG NO: HLL-CED-D5-056-00

SHEET NO: 01/01

REV:
DATE:

4

3

2

1