

EOI DOCUMENT

FOR

Empanelment of Aggregators for the supply of Aluminum Cuboids and other products as per Customized Packaging for onward supplies to Overseas countries

Tender No: HLL/SD/RBD/2022-23/EOI/11 Dt: 10.08.2022

E – Tendering



HLL Lifecare Limited

(A Govt. Of India Enterprise)

CIN : U25193KL1966GOI002621

HLL Bhavan, Poojappura,

Thiruvananthapuram -695012

Kerala, India

Tel: 0471 2775500, 0471 2358151

(EXTN – 600/606/531)

Website – www.lifecarehll.com

CONTENTS

Titles	Page No.
Notice Inviting Expression Of Interest (EOI)	2
General Instruction to Interested Bidder (GIB)	3-8
Instruction To Interested Bidder (ITB)	9-34
General Conditions of Contract (GCC)	35-39
Special Conditions of Contract (SCC)	40
Annexure – 01, Self Declaration	41
Annexure – 02, Bid Form	42
Annexure – 03 Undertaking letter for replacement of market complaint goods	43
Annexure – 04 Category details of Organization	44
Annexure - 05 Indemnity Certificate	45
Annexure -06 Performance Bank Guarantee Format	46
Annexure - 07 Check list	47
Annexure - 08 Self Declaration – Compliance to Rule 144 (xi) of the GFR, 2017	48
Annexure – 09 Self Declaration – Make In India Preference	49
Annexure – 10 Pre Contract Integrity Pact	50-56

HLL LIFECARE LIMITED
(A Government of India Enterprise)
Corporate Head Office, Poojappura.P.O,
Thiruvananthapuram – 695012, Kerala, India
Tel: 0471 2775500, 0471 2358151
(EXTN – 600/606/531)

NOTICE INVITING EXPRESSION OF INTEREST (EOI)

IFB No: HLL/SD/RBD/EOI/2022-23/EOI/11

10.08.2022

HLL Lifecare Limited (HLL), a Government of India Enterprise, invites Expression of Interest for empanelment of Aggregator(s) from interested and experienced parties for collaborating with HLL who are capable of executing the following item/work meeting the requirements as per our tender.

SI No	Particulars	Description
1	Name of Item/Work	Empanelment of Aggregators for the Supply of Aluminum Cuboids and other products as per Customized Packaging for onward supplies to Overseas countries
2	Location of Delivery	Designated ware houses of HLL Lifecare Ltd at Punjab/Delhi/Gurgaon
3	Brief description of Item/Work	First Stage - Empanelment of eligible, competent and experienced healthcare products supplier(s) for executing scope of work as mentioned in the EOI and as per EOI Terms and conditions. Qualified bidders(s) will be empanelled after finalization of EOI. Second Stage - Based on the requirement from time to time separate two part tender(s) shall be floated. Only the empanelled aggregators can participate in the tenders floated in this regard from time to time.
4	Bid Security/EMD	Rs.1,00,00,000 (Rupees One Crore only)
5	Bid fee	Rs.5000/- (Rupees Five Thousand only)
6	Period of completion	The qualified aggregators shall complete the entire scope of work of the second stage tender(s) within 90 days from placement of PO/Letter of Intent.
7	EOI Validity	365 days from the date of empanelment which may be extendable upto 2 more years on year to year basis based on satisfactory performance and mutual agreement
8	Eligibility criteria for Bidder(s)	As per Tender document
9	HLL A/c Details for payment of Bid Fees and EMD (Payment mode: NEFT/RTGS)	Name of Bank: HDFC BANK A/c number: 09960330000108 IFSC Code: HDFC0000996 Branch name: Pattom, Thiruvananthapuram
10	Last date and time for online submission of online bids	30-08-2022 at 15:00 hrs
11	Date and time of opening of e-tender	31-08-2022 at 15:00 hrs
12	Address for Communication at HLL regarding the tender	Vice President (Sourcing) Sourcing Division HLL Lifecare Limited Corporate & Regd Office, HLL Bhavan,Poojappura, Thiruvananthapuram-695012 E-mail: sdrbdsouth@lifecarehll.com

GENERAL INSTRUCTIONS TO BIDDERS

1. This EOI is an e-Tender and is being published online in Government eProcurement portal, <https://etenders.gov.in/e procure/app>
2. EOI documents can be downloaded free of cost from the Central Public Procurement Portal of Government of India (e-portal). All Corrigendum/extension regarding this e-tender shall be uploaded on this website i.e. <https://etenders.gov.in/e procure/app>.
3. The EOI and its corrigendum/extension will also be published in our company website, URL address: <http://www.lifecarehll.com/tender>.
4. The tendering process is done online only at Government eProcurement portal (URL address: <https://etenders.gov.in/e procure/app>). Aspiring bidder(s) may download and go through the tender document.
5. All bid documents are to be submitted online only and in the designated cover(s)/envelope(s) on the Government eProcurement website. Tenders/bids shall be accepted only through online mode on the Government eProcurement website and no manual submission of the same shall be entertained. Late tenders will not be accepted.
6. The complete bidding process is online. Bidder(s) should be in possession of valid Digital Signature Certificate (DSC) of class II or above for online submission of bids. Prior to bidding, DSC need to be registered on the website mentioned above. If the envelope is not digitally signed & encrypted the Purchaser shall not accept such open Bids for evaluation purpose and shall be treated as non-responsive and shall be rejected.
7. Bidder(s) are advised to go through “Bidder Manual Kit”, “System Settings” & “FAQ” links available on the login page of the e-Tender portal for guidelines, procedures & system requirements. In case of any technical difficulty, bidder(s) may contact the help desk numbers & email ids mentioned at the e-tender portal.
8. Bidder(s) are advised to visit CPPP website <https://etenders.gov.in> regularly to keep themselves updated, for any changes/modifications/any corrigendum in the Tender Enquiry Document. Conditional offers are liable for rejection.
9. The Aggregator to indemnify the HLL from any claims / penalties / statutory charges, liquidated damages, with legal expenses etc as charged by the customer.
10. While the Expression of Interest has been prepared in good faith, the Buyer does not make any commitment or warranty, express or implied, or accept any responsibility or liability, whatsoever, in respect of any statement or omission herein, or the accuracy, completeness or reliability of information contained herein, and shall incur no liability under any law, statute, rules or regulations as to the accuracy, reliability or completeness of this request, even if any loss or damage is caused by any act or omission on its part.
11. Bidders are requested to keep the information and details strictly confidential. We are looking for your support and co-operation in getting fully responsive Expression of interest.

12. The Buyer shall not be responsible for any expense incurred by Parties in connection with the preparation and delivery of their EOI and other expenses.
13. HLL reserves the right to reject any or all the Expressions of Interest without assigning any reason thereof.
14. The process of inviting EOI is for ascertaining various options available to HLL. After evaluation / examination of the offers, HLL may at its sole discretion decide further course of action.
15. HLL reserves the right to deal with the proposal in any manner without assigning any reasons for the same. The decision of the HLL in this regard shall be final.
16. Any false submissions/falsification of details and enclosures will lead to disqualification of the interested bidder(s).
17. Any disagreement regarding the scope of work after opening of bids will lead to disqualification of the bidder(s).
18. The bidder(s) are required to submit soft copies of their bids electronically on the CPP Portal, using valid Digital Signature Certificates. The instructions given below are meant to assist the Bidder(s) in registering on the CPP Portal, prepare their bids in accordance with the requirements and submitting their bids online on the Government eProcurement Portal.

18.1 Registration

- a) Bidder(s) are required to register in the Government e-procurement portal, obtain 'Login ID' & 'Password' and go through the instructions available in the Home page after log in to the CPP Portal (URL: <https://etenders.gov.in/eprocure/app>), by clicking on the link "Online Bidder(s) Enrolment" on the CPP Portal which is free of charge.
- b) As part of the enrolment process, the Bidder(s) will be required to choose a unique user name and assign a password for their accounts.
- c) Bidder(s) is advised to register their valid email address and mobile numbers as part of the registration process. These would be used for any communication from the CPP Portal.
- d) They should also obtain Digital Signature Certificate (DSC) in parallel which is essentially required for submission of their application. The process normally takes 03 days' time. The Bidder(s) are required to have Class II or above digital signature certificate or above with both signing and encryption from the authorized digital signature Issuance Company. Please refer online portal i.e. - <https://etenders.gov.in/eprocure/app> for more details.
- e) Upon enrolment, the Bidder(s) will be required to register their valid Digital Signature Certificate (Class II or above Certificates with signing key usage) issued by any Certifying Authority recognized by CCA India (e.g. Sify /nCode / eMudhra etc.), with their profile.
- f) Bidder(s) then logs in to the site through the secured log-in by entering their user ID/password and the password of the DSC / e-Token.

- g) The Bidder(s) intending to participate in the bid is required to register in the e-tenders portal using his/her Login ID and attach his/her valid Digital Signature Certificate (DSC) to his/her unique Login ID. He/She have to submit the relevant information as asked for about the firm/contractor. The Bidder(s), who submit their bids for this tender after digitally signing using their Digital Signature Certificate (DSC), accept that they have clearly understood and agreed the terms and conditions including all the Forms/Annexure of this tender.
- h) Only those Bidder(s) having a valid and active registration, on the date of bid submission, shall submit bids online on the e-procurement portal.
- i) Only one valid DSC should be registered by a Bidder(s). Please note that the Bidder(s) are responsible to ensure that they do not lend their DSCs to others which may lead to misuse.
- j) Ineligible Bidder(s) or Bidder(s) who do not possess valid & active registration on the date of bid submission, are strictly advised to refrain themselves from participating in this tender.

18.2 Searching for Tender Documents

- a) There are various search options built in the CPP Portal, to facilitate Bidder(s) to search active tenders by several parameters. These parameters could include Tender ID, Organization Name, Form of Contract, Location, Date, Value etc. There is also an option of advanced search for tenders, wherein the Bidder(s) may combine a number of search parameters such as Organization
- b) Once the Bidder(s) has selected the tenders they are interested in, they may download the required documents/tender schedules. These tenders can be moved to the respective 'My Tenders' folder. This would enable the CPP Portal to intimate the Bidder(s) through SMS/ e-mail in case there is any corrigendum issued to the tender document.
- c) The Bidder(s) should make a note of the unique Tender ID assigned to each tender, in case they want to obtain any clarification/help from the Helpdesk

18.3 Preparation of Bid

- a) Bidder(s) should take into account any corrigendum published on the tender document before submitting their bids.
- b) Please go through the tender document carefully to understand the documents required to be submitted as part of the bid. Please note the number of covers in which the bid documents have to be submitted, the number of documents - including the names and content of each of the document that need to be submitted. Any deviations from these may lead to rejection of the bid.
- c) Bidder(s), in advance, should get ready the bid documents to be submitted as indicated in the tender document / schedule and generally, they can be in PDF / XLS / RAR / DWF / JPG formats. Bid documents may be scanned with 100 dpi with black and white option which helps in reducing size of the scanned document.
- d) To avoid the time and effort required in uploading the same set of standard documents which are required to be submitted as a part of every bid, a provision of

uploading such standard documents (e.g. PAN card copy, annual reports, auditor certificates etc.) has been provided to the Bidder(s). Bidder(s) can use “My Space” or “Other Important Documents” area available to them to upload such documents. These documents may be directly submitted from the “My Space” area while submitting a bid, and need not be uploaded again and again. This will lead to a reduction in the time required for bid submission process.

- e) Note: My Documents space is only a repository given to the Bidder(s) to ease the uploading process. If Bidder(s) has uploaded his Documents in My Documents space, this does not automatically ensure these Documents being part of Technical Bid.

19. More information useful for submitting online bids on the CPP Portal may be obtained at <https://etenders.gov.in/eprocure/app>

20. Bidder(s) is required to upload the digitally signed file of scanned documents. Bid documents may be scanned with 100 dpi with black and white option which helps in reducing size of the scanned document. Uploading application in location other than specified above shall not be considered. Hard copy of application shall not be entertained.

21. Any queries relating to the process of online bid submission or queries relating to CPP Portal in general may be directed to the 24x7 CPP Portal Helpdesk. The 24x7 Help Desk details are as below: -

For any technical related queries please call at 24 x 7 Help Desk Number:
0120-4001 062, 0120-4001 002, 0120-4001 005, 0120-6277 787

Note:- International Bidder(s) are requested to prefix +91 as country code

E-Mail Support: For any Issues or Clarifications relating to the published tenders, Bidder(s) are requested to contact the respective Tender Inviting Authority

Technical - support-eproc@nic.in, Policy Related - cppp-doe@nic.in

22. Bidder(s) is requested to kindly mention the URL of the portal and Tender ID in the subject while emailing any issue along with the contact details.

23. Any queries relating to the tender document and the terms and conditions contained therein should be addressed to the Tender Inviting Authority for a tender or the relevant contact person indicated in the tender. Address for communication and place of opening of bids:

Vice President(Sourcing)
HLL Lifecare Ltd.
HLL Bhavan, Poojappura,
Thiruvananthapuram - 695012,
Kerala, India
Tel: +91 4712354949 (EXT 242 / 272 / 273)
Email – sdrbdsouth@lifecarehll.com

24. The bids shall be opened online at the **Office of the Vice President (Sourcing)** in the presence of the Bidder(s)/their authorized representatives who wish to attend at the above address. If the tender opening date happens to be on a holiday or non-working

day due to any other valid reason, the tender opening process will be done on the next working day at same time and place.

25. More details can be had from the Office of the Vice President (Sourcing) during working hours. The Tender Inviting Authority shall not be responsible for any failure, malfunction or breakdown of the electronic system while downloading or uploading the documents by the Bidder(s) during the e-procurement process.
26. A firm/Bidder(s) shall submit only one bid in the same bidding process. A Bidder(s) (either as a firm or as an individual or as a partner of a firm) who submits or participates in more than one bid will cause all the bids in which the Bidder(s) has participated to be disqualified.

27. Online EOI Process:

The EOI process shall consist of the following stages:

- i. Downloading of EOI document: Tender document will be available for free download on Government e-procurement portal (URL: <https://etenders.gov.in/e procure/app>).
 - ii. Publishing of Corrigendum: All corrigenda shall be published on Government e-procurement portal (URL: <https://etenders.gov.in/e procure/app>) and HLL website (URL address: <http://www.lifecarehll.com/tender>) and shall not be available elsewhere.
 - iii. **Bid submission:** Bidder(s) need to submit their bids along with supporting documents to support their eligibility, as required in this EOI document on Government e-procurement portal. No manual submission of bid is allowed and manual bids shall not be accepted under any circumstances.
 - iv. **Opening of Technical Bid and Bidder(s) short-listing:** The technical bids will be opened, evaluated as per the eligibility and technical qualifications. All documents in support of technical qualifications shall be submitted (online). Failure to submit the documents online will attract disqualification. All the Bidder(s)s who meet the technical evaluation criteria will be empanelled. After empanelment, as and when requirement arises, HLL will invite Two part tender from the empanelled Aggregator, based on the specific nature of requirement.
28. HLL Life care Limited does not bind themselves to accept the lowest or any bid or to give any reasons for their decisions which shall be final and binding on the Bidder(s).
29. HLL Lifecare Limited reserves to themselves the right of accepting the whole or any part of the tender and Bidder(s) shall be bound to perform the same at his quoted rates.
30. In case, it is found during the evaluation or at any time before placing of PO or after its execution and during the period of subsistence thereof, that one or more of the eligibility conditions have not been met by the Bidder(s) or the applicant has made material misrepresentation or has given any materially incorrect or false information, appropriate legal/penal, action shall be taken by HLL Lifecare as deemed fit.

31. Conditional bids and bids not uploaded with appropriate/desired documents may be rejected out rightly and decision of HLL Lifecare Limited in this regard shall be final and binding.
32. The technical bids should be uploaded as per the requirements of EOI and should not contain price information otherwise the bid will be rejected.
33. HLL Lifecare Limited Ltd. reserves the right to verify the claims made by the Bidder(s) and to carry out the capability assessment of the Bidder(s) and the HLL Lifecare Limited's decision shall be final in this regard.
34. HLL Lifecare Limited Ltd. reserves the right to amend or withdraw any of the terms and conditions contained in the EOI document including scope of work or reject any or all EOIs without giving any notice or assigning any reasons.
35. Submission Process:

For submission of bids, all interested Bidder(s) have to register online as explained above in this document. After registration, Bidder(s) shall submit their Technical bid on Government e-procurement portal (URL: <https://etenders.gov.in/eprocure/app>).

Note:- It is necessary to click on “Freeze bid” link / icon to complete the process of bid submission otherwise the bid will not get submitted online and the same shall not be available for viewing/ opening during bid opening process.

Vice President (Sourcing)

INSTRUCTIONS TO THE BIDDER(S) (ITB)

Section 1

I. COMPANY BACKGROUND:

HLL Lifecare Limited (HLL) is a public sector undertaking under the administrative control of the Ministry of Health & Family Welfare, Government of India. HLL's purpose of business is to provide quality healthcare products and services at affordable rates. In its quest to become a comprehensive healthcare solutions provider, HLL had diversified into hospital products and healthcare services, while nurturing its core business of providing quality contraceptives. HLL is offering solution for retailing and making available range of HLL's quality healthcare products / Sanitary Napkins / Condoms etc. through state-of-art technologies. HLL also launched several initiatives in the service sector - for medical infrastructure development, diagnostics centre's and retail chain of pharmacy outlets and procurement & consultancy services.

II. SCOPE OF WORK OF THE AGGREGATOR

HLL invites bids from the eligible, competent and experienced healthcare products supplier(s) who are eligible for executing the scope of work as mentioned in the EOI and as per EOI Terms & Conditions. Qualified Bidder(s) will be empanelled after finalization of the EOI. Based on the requirement from time to time, separate two part tenders shall be floated. Only the empanelled aggregators can participate in the tenders floated in this regard from time to time. The qualified aggregators shall complete the entire scope of work of the second stage of the tender within 90 days from placement of PO/Letter of Intent.

- a) Design, Development and Supply of small Aluminum Cuboid (375mm x 375mm x 375mm) as per the attached specification and Drawing. Bidders have to submit 72 sample small Aluminium Cuboid as per the specification and drawing for demonstration during the EOI evaluation stage which shall form a part of selection process for the empanelment.
- b) Design, Development and Supply of Mother Cube / Pallet of size not more than 4ft x 4ft x 6ft as per the attached specification and drawing which can carry 36 small Aluminum cuboids. Bidders have to submit 2 sample Mother Cube / Pallet as per the specification and drawing for demonstration during the EOI evaluation stage which shall form a part of selection process for the empanelment.
- c) Design, Development and Supply of Trays as per the specification and drawing. Bidders have to submit 432 Trays as per the specification and drawing for demonstration during the EOI evaluation stage which shall form a part of selection process for the empanelment.
- d) Supply of Electronic Tablets with suitable software: Development and deployment of suitable software for retrieving all data pertaining to the contents packed in the cuboids, write up of each item such as indication, contraindications, adverse events in multiple languages (86 language). Bidders have to submit 2 electronic tablets with suitable software along with sample data as mentioned above for demonstration during the EOI evaluation stage which shall form a part of selection process for the empanelment.
- e) Supply of Pharmaceutical products, surgical items and equipments in HLL designated warehouse and arrange as per serial number in the storage racks. A sample product category list for reference is mentioned in clause IV. This is only an indicative list, detailed product list based on the actual requirement shall be communicated during the

2nd stage of bidding process. The aggregator shall invariably be able to supply all the required items (100%) mentioned in the 2nd stage of tendering process.

- f) Packaging/Kitting and Assembly of products in the trays and such trays are placed inside the small aluminium cuboids and 36 such small aluminium cuboids are arranged on pallets as a mother cube, at designated HLL warehouse
- g) Loading, Unloading and stacking of materials at designated HLL Warehouse shall be under the scope of empanelled Aggregator.
- h) The Aggregator should ensure that all the product supplied should have adequate product Liability undertaking from the Principal manufacturer which shall cover the entire shelf life/useable life of the product wherever applicable. Documentary evidence for the same is to be provided in the second stage of the tender.
- i) The aggregator shall arrange a product liability insurance coverage as applicable for foreign countries to the tune of minimum Rs.10 Crores for a period of initial 3 years which need to be extended as per terms and conditions of PO. Documentary evidence for the same is to be shared with HLL within 14 days from the date of placement of PO / LOI in the second stage of the tender.
- j) The empanelled aggregators need to supply additional quantities, required for testing the batches as part of receiving inspection and retaining samples, free of cost for Pharmaceutical and surgical products as per HLL's sampling plan. The item wise quantity details shall be provided in the second stage of the tendering process.
- k) If any batch is not found in compliance with the specification, the aggregator needs to replace the same with good quality items at his cost within the stipulated time
- l) MRP should not be printed on any package.
- m) HLL shall charge 1.25% of the total purchase order value with applicable GST against each purchase order issued to the Aggregator(s) time to time during the EOI validity period towards testing and utility charges from the Aggregator(s)
- n) All Pharma products should be manufactured from a Valid USFDA/WHO Pre-Qualification for Products//EU GMP for Manufacturing Facility/WHO GMP Approval for Manufacturing Facility wherever applicable. Details shall be mentioned in the second stage of the tender
- o) If the offered products are manufactured from more than one unit, all the units shall be USFDA/WHO Pre-Qualification for Products//EU GMP for Manufacturing Facility/WHO GMP Approval for Manufacturing Facility.
- p) For all products coming under Surgical / Equipment Category must have ISO/BIS/CE/or any other quality assurance certification as applicable issued by the concerned authorities wherever applicable. Details shall be mentioned in the second stage of the tender

III. SCOPE OF EOI

HLL invites bid from the eligible, competent and experienced healthcare products supplier(s) who are eligible for executing the scope of work as mentioned in the EOI and as per EOI conditions. Qualified bidder(s) will be empanelled after finalization of EOI. Based on the requirement from time to time separate two part tenders shall be floated. Only the empanelled aggregators can participate in the second stage of the tenders floated in this regard from time to time .The qualified aggregator(s) shall complete entire scope of work within 90 days from placement of PO/Letter of Intent.

Participating Bidder is requested to submit the bid fee and EMD online on or before the due date as mentioned in the EOI. The bidder who failed to submit the Bid fee and EMD before the submission deadline will be considered as technically non responsive

IV. PRODUCT CATEGORY FOR REFERENCE

SI.No	Product Category
1	Aluminium Baby Cuboid
2	Aluminium Mother Cuboid
3	Electronic Tablet with suitable software
4	Pharma products
5	Medical Equipments
6	Surgical products
7	Other related stationary items

V. TECHNICAL SPECIFICATION

a. Small Aluminum Cuboid (375mm x 375mm x 375mm) as per the below specification.

- Size: 375mm x 375mm x 375mm
- The Material used to make the box will be 1.50mm Aluminium without any welded joints.
- Can survive extreme heat (+60 deg C) and extreme cold (- 20deg C)
- Should be able to open Horizontally or Vertically (both) in 2 parts to suit and assist quick dispensing and Maximum utility of the First Aid products .
- The box will be die moulded (drawn) to ensure it is Waterproof
- Should have 3 carrying options – Brief case with Handle / Strolley with wheels / Cross shoulder strap
- The box should be capable of installation of a Tablet PC in its inside cover
- Should have modular plastic trays inside, of at least 4 different sizes to securely fit the wide assortment of pharma products .
- **Drawing of the Small Aluminium cuboid is attached as Annexure A**

b. Mother Cube / Pallet of size not more than 4ft x 4ft x 6ft as per the below specification which shall carry 36 small Aluminium cuboids.

- Size: 4ft x 4ft x 6ft
- The Pallet design to be versatile such that any of the 36 small boxes can be immediately pulled out without unloading the ones which are not required .
- Utility oriented design so that the pallet can be used as a hospital shelf with various products and equipment instead of just a transport facilitator .
- Load Bearing – 1 MT dead weight , 3MT of jerk load
- Air drop / Winching capability
- Castors with springs and brakes
- Weatherproof coating and finish

- The Pallet should not have any Welded joints
 - **Drawing of the Mother Cube / Pallet is attached as Annexure B**
- c. Design, Development and Supply of Trays as per the below specification**
- Drawing of the Tray is attached as Annexure C
- d. Supply of 2 Electronic Tablets with suitable software. Development and deployment of suitable software along with sample data for retrieving all data pertaining to the contents packed in the cuboids, write up of each item such as indication, contraindications, adverse events in multiple languages (86 language). The specification is mentioned below;**

S.No.	Item	Specification Details
1	Display	Touch Screen, Minimum 10.1 Screen Size, Max Resolution 1900x1200 Pixels or better
2	Processor	2.2 GHz or Above (Qualcomm Snapdragon or better)
3	RAM	3 GB or Above
4	Operating System	Android 9.0 or Above
5	Storage	32 GB or Above
6	Interfaces/Connectors	USB Type C, USB 2.0
7	Communication Modules	Wifi, 4G or above (Optional feature based on requirement)
8	Power Adaptor	6V, Fast Charger
9	Battery	Lithium Polymer, 7500mah or above, minimum 6 to 8 continuous hours usage , Removable/Replaceable
10	Enclosure	Water Proof, Dust Proof Very Rugged, IP 67/68 or Above
11	Temperature	Operating: -10 ⁰ to +55 ⁰
12	Humidity	95% RH Non Condensing
13	Safety	Minimum CE and any other
14	Dimensions	LxWxH - 6.69 x 0.39 x 9.58
15	Weight	Less than 900g
16	Certifications	MIL-STD-810G, MIL-STD-461F certified (Military Grade)
17	Security	Preferably in-built Defense grade security
18	Camera/Scanner	Barcode Scanner(Optional as decided by future requirement)
19	Audio	Speaker and Mic with headphone ports

- e. All Pharma products should be manufactured from a Valid USFDA/WHO Pre-Qualification for Products/EU GMP for Manufacturing Facility/ WHO GMP. Approval for Manufacturing Facility. Product wise requirement shall be communicated in the second stage of the tendering process**
- f. For Surgical items / Equipment products must have ISO/BIS/CE or any other quality assurance certification wherever applicable issued by the concerned authorities and product wise requirement shall be communicated in the second stage of the tendering process**

VI. DRAWINGS

Small Aluminum Cuboid – BOX BOTTOM PART - Annexure A

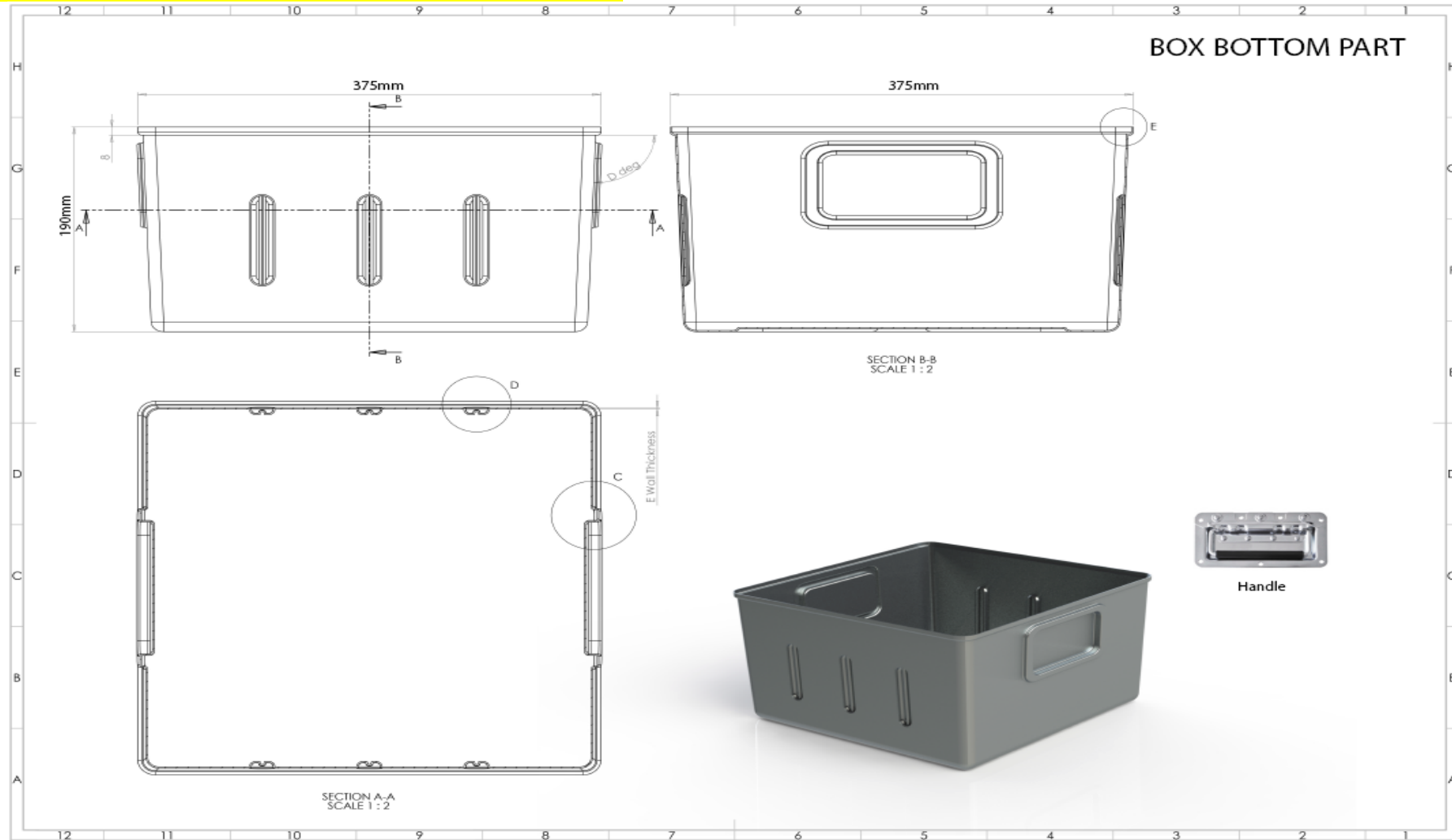

Small Aluminum Cuboid – BOX TOP PART - Annexure A

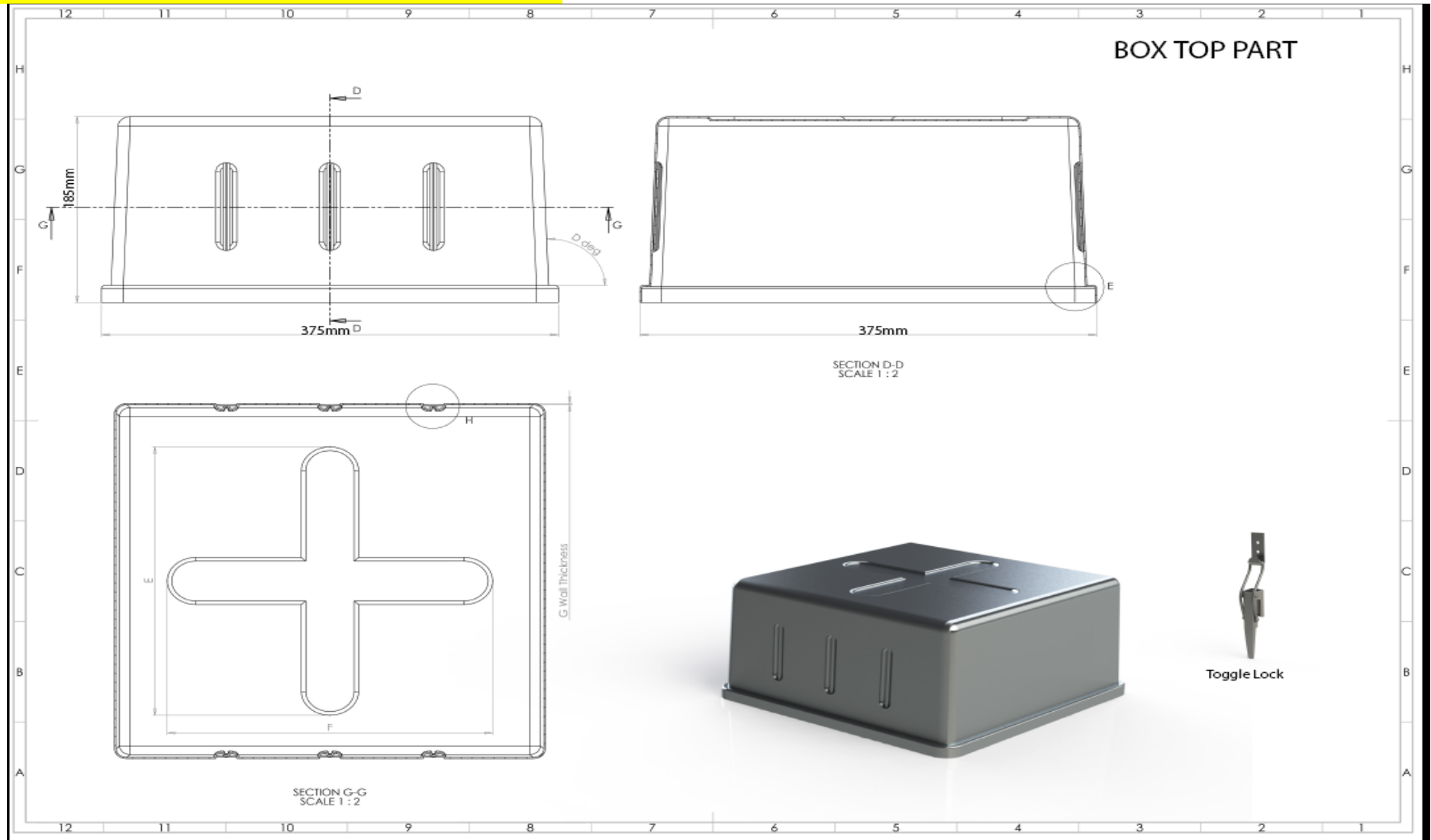

Mother Cube / Pallet - Annexure B

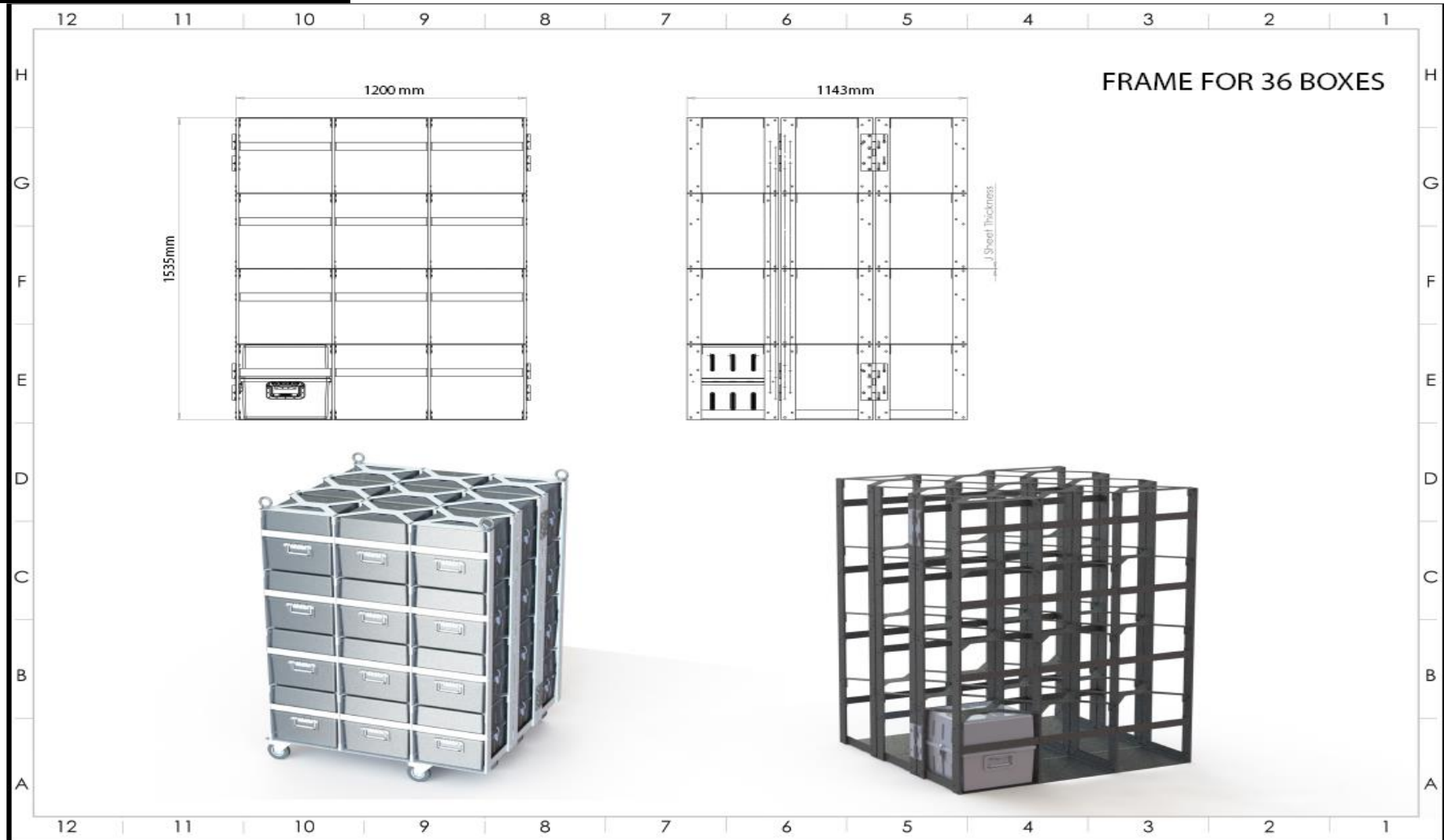

TRAY- Annexure C

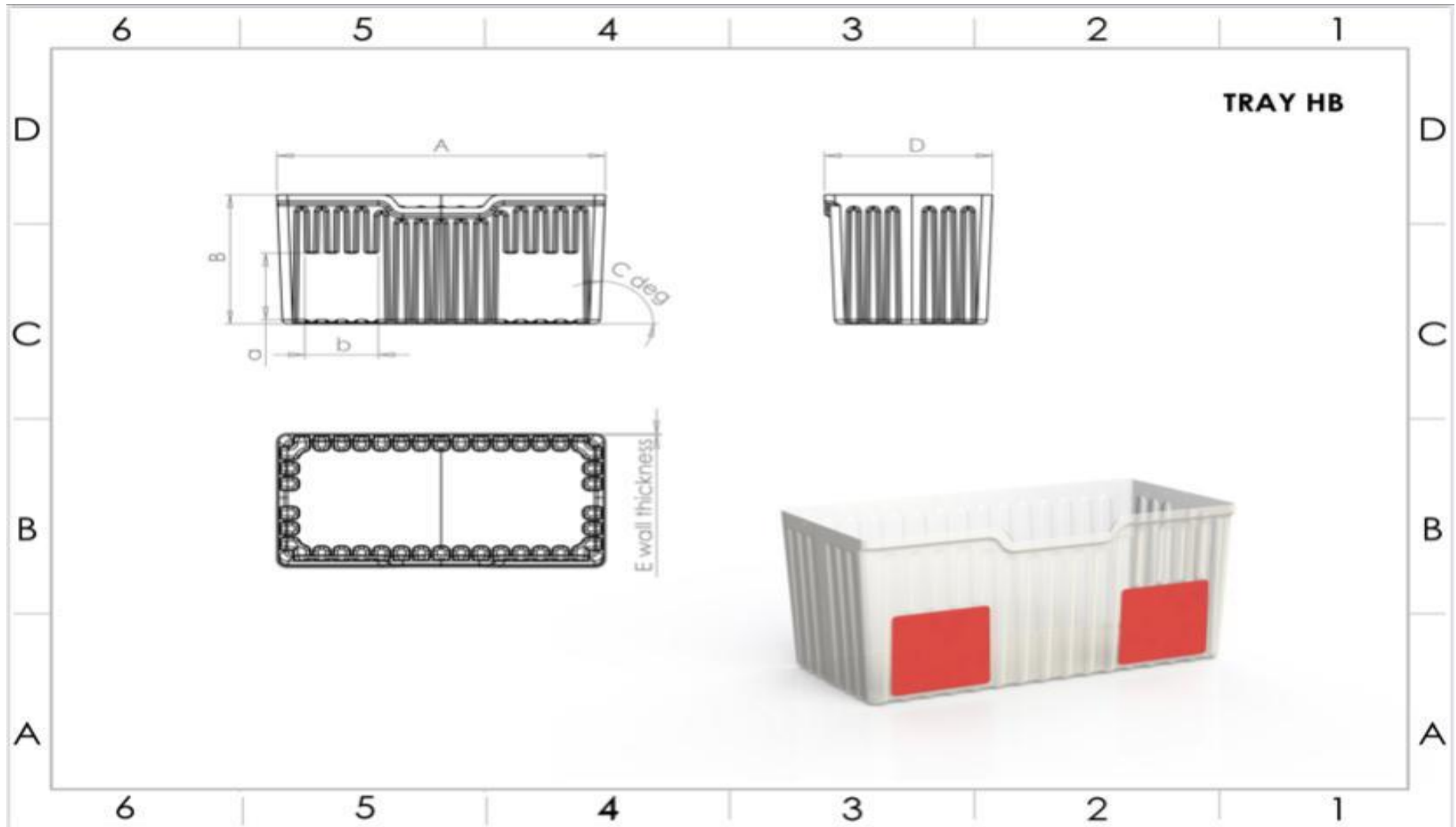

TRAY- Annexure C

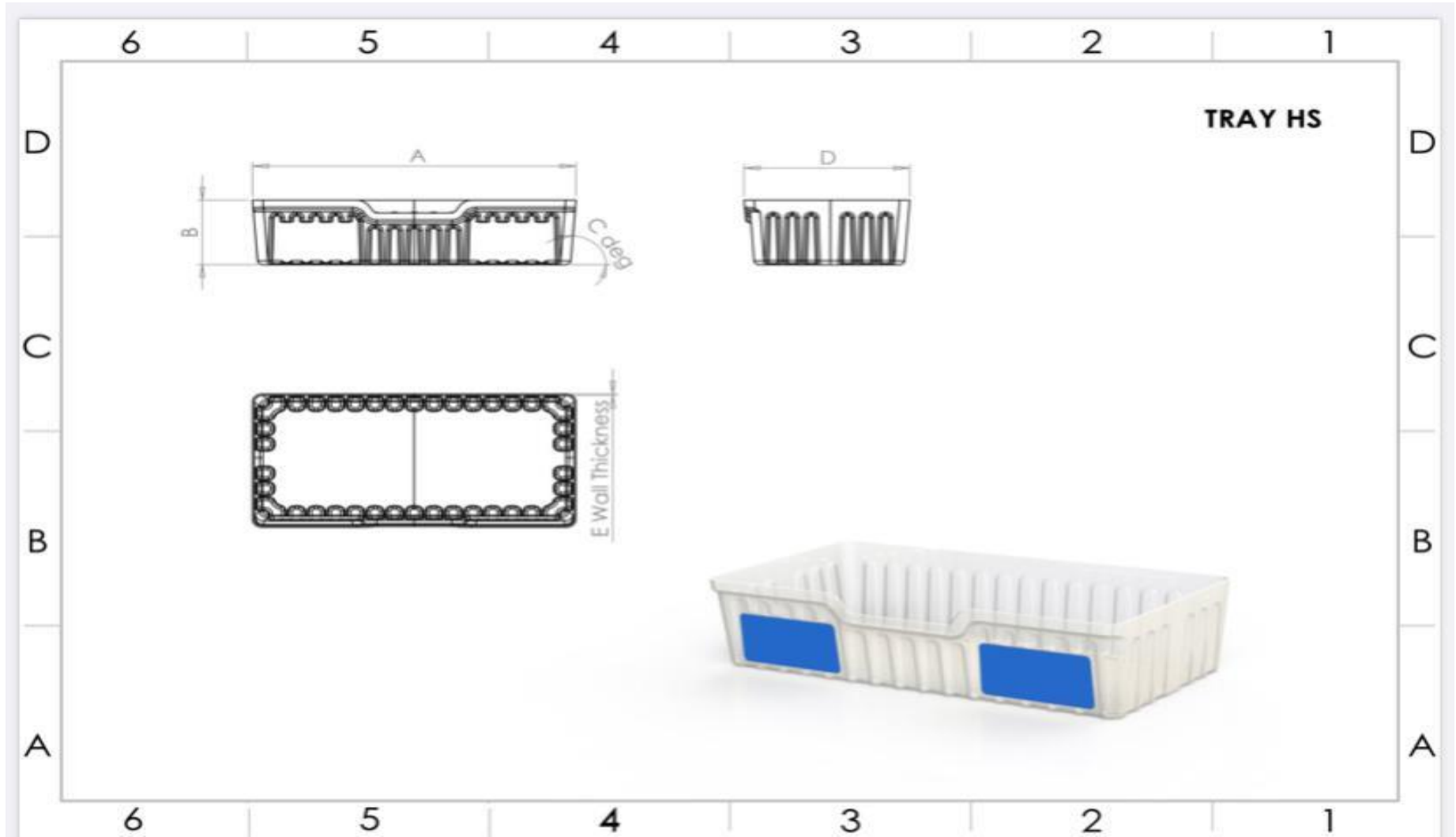

VII. SUPPLY LOCATION

Supply to be made on Door delivery basis to the designated warehouse of **HLL Lifecare Limited at Punjab/Delhi/Gurgaon**. Details shall be communicated in the second stage of tendering process

VIII. AWARD OF EMPANELMENT

All the Bidder(s) whose bids are determined to be substantially responsive will be empanelled. The EOI inviting Authority reserves the right to accept or reject any BID and to cancel the bidding process and reject all bids at any time prior to the award of contract, without thereby incurring any liability to HLL.

In the second stage process, as and when requirement arises based on the specific nature of the work, HLL shall invite separate Two stage tender during the validity period of EOI, in which Technical and Financial quotes are to be submitted by the empanelled aggregator.

IX. GENERAL INFORMATION TO BIDDERS

- a) A firm/Bidder(s) shall submit only one bid in the same bidding process. A Bidder(s) (either as a firm or as an individual or as a partner of a firm) who submits or participates in more than one bid will cause all the proposals in which the Bidder(s) has participated to be disqualified.
- b) Purchase preference to Micro and Small Enterprises (MSEs): Purchase preference will be given to MSEs as defined in Public Procurement Policy for Micro and Small Enterprises (MSEs) Order, 2012 dated 23.03.2012 issued by Ministry of Micro, Small and Medium Enterprises and its subsequent Orders/Notifications issued by concerned Ministry.
- c) Bidder(s) who are eligible as per the Provisions of Public Procurement –Preference to Make in India Order No.P-45021/12/2017PP (BE-II), 2017 (published by Department for Promotion of Industry and Internal Trade) inclusive of the latest amendments are eligible to participate in the tender. A self declaration as per Annexure 09 with respect to this order must be submitted.
- d) Any Bidder(s) from a country which shares a land border with India will be eligible to bid in this tender only if the Bidder(s) is registered with Competent Authority, as per order no F.No.6/18/2019-PPD dated 23-July-2020 (Rule 144 (xi) of the GFR, 2017 and any amendments issued thereafter) inclusive of the latest amendments issued by Ministry of Finance, GOI at Annexure 08 of this bidding document. The Bidder(s) must comply with all provisions mentioned in this order. A self-declaration as per Annexure 08 with respect to this order must be submitted.
- e) Bidder(s) who has been de-recognized/debarred/banned/blacklisted by any other State Government / Central Govt. Organization /State Medical Corporations/ Director Health Services and or convicted by any court of law due to (i) quality failure of the drug(s) supplied (NSQ/ Spurious/ Adulterated/ Misbranded etc.) (ii) Submission of fake or forged documents (iii) Submission of incorrect information / Suppression of vital information & facts can't participate in the tender during the period of de-recognition / debarment/ Banned/blacklisted. Bidder(s) / manufacturing unit which has been de-recognized/ debarred/banned/blacklisted by State Medical Corporation for any reasons can't participate in the tender during the period of de-recognition/debarment/banned.

- f) Any Bidder(s) who has been convicted by a competent court of law for supplying (NSQ/ Spurious/ Adulterated/ Misbranded etc.) drugs within a period of last 3 years from the date of floating of tender shall not be eligible to participate in the tender.
- g) Any Bidder(s) who is a distributor/ authorized agent then they should ensure that their Principal manufacturer has not been de-recognized/debarred/banned/blacklisted by any other State Government / Central Govt. Organization / State Medical Corporations/ Director Health Services and or convicted by any court of law due to (i) quality failure of the drug(s) supplied (NSQ/ Spurious/ Adulterated/ Misbranded etc.) (ii) Submission of fake or forged documents (iii) Submission of incorrect information / Suppression of vital information & facts can't participate in the tender during the period of de-recognition / debarment/ Banned/blacklisted. Bidder(s) / manufacturing unit which has been de-recognized/ debarred/banned/blacklisted by any State Medical Corporation for any reasons can't participate in the tender during the period of de-recognition/debarment/banned.

Section 2:

1. MINIMUM ELIGIBILITY CRITERIA FOR BIDDER(S)

The Bidder(s) should be fulfilling the following conditions.

- 1.1. The Bidder(s) should have an average annual turnover of **Rs.40 crores (Rupees Forty crore) for last three years (2019-20, 2020-21 and 2021-22)**
- 1.2. The Bidder(s) should have experience in procurement/supplying/Distribution of Pharmaceutical/surgical/ Medical equipment items for a period of minimum 3 years i.e. 2019-20, 2020-21 and 2021-22
- 1.3. Bidder(s) should be able to submit 72 small sample Aluminum Cuboid (375mm x 375mm x 375mm) as per the specification and drawing for demonstration during the EOI evaluation stage which shall form a part of selection process for the empanelment. The cuboids are to be arranged at HLL warehouse at Gurgaon after opening and documentary evaluation of technical bid. The cuboids are to be arranged within 7 days from the intimation from HLL
- 1.4. Bidder(s) should be able to submit 2 sample Mother Cube / Pallet of size not more than 4ft x 4ft x 6ft as per the attached specification and drawing which shall carry 36 small Aluminium cuboids for demonstration during the EOI evaluation stage which shall form a part of selection process for the empanelment. The mother cuboid / pallet is to be arranged at HLL warehouse at Gurgaon after opening and documentary evaluation of technical bid. The mother cuboids is to be arranged within 7 days from the intimation from HLL
- 1.5. Bidder should able to submit 432 Trays as per the specification and drawing for demonstration during the EOI evaluation stage which shall form a part of selection process for the empanelment. The tray is to be arranged at HLL warehouse at Gurgaon after opening and documentary evaluation of technical bid. The tray is to be arranged within 7 days from the intimation from HLL
- 1.6. Bidders have to submit an electronic tablet with suitable software along with sample data for retrieving all data pertaining to the contents packed in the cuboids, write up of each item such as indication, contraindications, adverse events in multiple languages (86 language) for demonstration during the EOI evaluation stage which shall form a part of selection process for the empanelment. The tablet with suitable software along with sample data is to be arranged at HLL warehouse at Gurgaon after opening and documentary evaluation of technical bid. The tablet is to be arranged within 7 days from the intimation from HLL

2. COST OF BIDDING

- 2.1 The Bidder(s) shall bear all costs associated with the preparation and submission of its bid, and "the Purchaser", will in no case be responsible or liable for these costs, regardless of the conduct or outcome of the bidding process.
- 2.2 Tender documents may be downloaded free of cost from the Government e-procurement portal (URL: <https://etenders.gov.in/eprocure/app>). However, Bid fee, as mentioned in the notice inviting EOI, is required to be submitted online (NEFT/RTGS) as mentioned in the notice inviting EOI.

3. GETTING INFORMATION FROM WEB PORTAL

- 3.1. All prospective Bidder(s) are expected to see all information regarding submission of bid for the Work published in the e tender website during the period from the date of publication of notice inviting EOI for the Work and up to the last date and time for submission of bid. Non observance of information published in the website shall not be entertained as a reason for any claim or dispute regarding a tender at any stage.
- 3.2. All bids shall be submitted online on the Government e-procurement portal only in the relevant envelope(s)/ cover(s), as per the type of tender. No manual submission of bids shall be entertained for the tenders published through Government e-procurement portal under any circumstances.
- 3.3. The Government e-procurement portal shall not allow submission of bids online after the stipulated date & time. The Bidder(s) is advised to submit the bids well before the stipulated date & time to avoid any kind of network issues, traffic congestion, etc. In this regard, the department shall not be responsible for any kind of such issues faced by Bidder(s).

4. BIDDING DOCUMENTS

4.1. Content of Bidding Documents

The bidding documents shall consists of the following unless otherwise specified

- a. Notice Inviting EOI (EOI)
- b. General Instruction to Interested Bidder(s)
- c. Instructions to Interested Bidder(s)
- d. General Conditions of Contract (GCC)
- e. Special Conditions of Contract (SCC)
- f. Annexures to Bid for Interested Bidder(s)
- g. Product Category for reference -Section 1 - Clause no.IV

- 4.2. The Interested Bidder(s) is required to login to the e-procurement portal and download the listed documents from the website as mentioned in EOI. He shall save it in his system and undertake the necessary preparatory work off-line and upload the completed bid at his convenience before the closing date and time of submission.
- 4.3. The Prospective Bidder(s) is expected to examine carefully all instructions, Conditions of Contract, Annexure, Terms, Product List in the Bid Document. Failure to comply with the requirements of Bid Document shall be at the Bidder(s)'s own risk.

5. CLARIFICATION OF BIDDING DOCUMENTS

- 5.1. An prospective Bidder(s) requiring any clarification of the bidding documents shall contact the office of the Tender Inviting Authority on any working day between 10 AM and 5 PM.
- 5.2 In case the clarification sought necessitates modification of the bid documents, being unavoidable, the Tender Inviting Authority may effect the required modification and publish them in the website through corrigendum.

6. AMENDMENT TO BIDDING DOCUMENTS

- 6.1. Before the deadline for submission of bids, the Tender Inviting Authority may modify the bidding document by issuing addenda.
- 6.2. Any addendum thus issued shall be a part of the bidding documents which will be published in the e-tender website and HLL website. The Tender Inviting Authority will not be responsible for the prospective Bidder(s) not viewing the website in time.
- 6.3. If the addendum thus published does involves major changes in the scope of work, the Tender Inviting Authority may at his own discretion, extend the deadline for submission of bids for a suitable period to enable prospective Bidder(s) to take reasonable time for bid preparation taking into account the addendum published.

7. PREPARATION OF BIDS

7.1 Language of the Bid

All documents relating to the bid shall be in the English language.

7.2 Documents to be submitted along with the Technical Bid for Empanelment of Aggregator

The online EOI submitted by the Bidder(s) shall comprise the following

- a) Self Declaration as per Annexure 1
- b) Bid form as per Annexure-2
- c) Documentary proof attested by Chartered Accountant for establishing the average annual turnover of Bidder(s) having a minimum average annual turnover of Rs.40 Crores (Rupees Forty Crores only) during the last three years i.e. 2019-20, 2020-2021 and 2021-2022 (original/ provisional).
- d) Last three years Purchase orders received from CentralGovts/ StateGovts/ PSUs/ Autonomous agencies/ other institutions to prove the experience in procurement/supplying/Distribution of Pharmaceutical/surgical/ equipment. Copy of work orders in support of their claims during the preceding three years ie 2019-20. 2020-21 & 2021-22 shall be uploaded.
- e) Bidder(s) should submit a non-conviction certificate to the effect that the bidder has not been convicted during the preceding three years and that no case / proceedings is pending against the manufacturer in any Court of Law in India
- f) Power of attorney for signatory of bid in Rs 200/- stamp paper duly notarized.
- g) Copy of GST Certificate (self-attested copy)
- h) Copy of Permanent Account Number (Self-attested Copy)
- i) Certificate of incorporation and associated documents like Article of Association and Memorandum of Association/Partnership deed/HUF etc as applicable. (Self-attested Copy).
- j) Under taking letter for replacement of complaint/defective goods as per Annexure-3

- k) Annexure 4 - Category details of organization, in case of MSME / MSE, If the Bidder(s) is a MSME, it shall declare in the bid document the Udyog Aadhar Memorandum Number issued to it under the MSMED Act, 2006. If a MSME Bidder(s) do not furnish the UAM Number along with bid documents, such MSME unit will not be eligible for the benefits available under Public Procurement Policy for MSEs Order 2012.”
- l) Duly filled, signed and sealed Annexure 05 - Indemnity Certificate
- m) Annexure 07 - Check List
- n) Annexure 08 – Compliance To Rule 144 (XI) of GFR 2017 (Self Declaration)
- o) Annexure 09 - Make In India Preference (Self Declaration)
- p) Annexure 10 - Pre Contract Integrity Pact

Note: If any of the above documents are not applicable for eligible Bidder(s) then they shall attach a “NOT APPLICABLE “statement mentioning the justification for the same.

All Annexure must be duly signed and sealed while submitting the same.

Bidder(s) shall not make any addition, deletion or correction in any of the bid documents. If tampering of documents is noticed during tender evaluation, the bid will be rejected and the Bidder(s) will be blacklisted.

8. Selection Process

The Technical Evaluation Committee (TEC) appointed by the HLL will screen the parties based on the Eligibility Criteria. Evaluation of suitable software with sample data for retrieving all data pertaining to the packed contents in the cuboid, evaluation of sample Aluminum Cuboids, Trays, Mother/Pallet cuboid, shall be part & parcel of selection process. The firms that fulfill eligibility criteria shall be technically qualified and empanelled. Based on the requirement from time to time separate two part tender(s) shall be floated.

9. Currencies of Bid and Payment

The currency of bid and payment shall be quoted by the Bidder(s) entirely in Indian Rupees. All payments shall be made in Indian Rupees only.

10. SUBMISSION OF BIDS

The Interested Bidder(s) shall submit their bid online only through the Government eProcurement portal (URL: <https://etenders.gov.in/e procure/app>) as per the procedure laid down for e-submission as detailed in the web site. For e tenders, the Interested Bidder(s) shall download from the portal. The Bidder(s) shall fill up the documents and submit the same online using their Digital Signature Certificate. On successful submission of bids, a system generated receipt can be downloaded by the Bidder(s) for future reference. Copies of all certificates and documents shall be uploaded while submitting the tender online.

The tender is invited in **1 Envelope system** from the registered and eligible firms at CPP Portal.

Envelope - I (Bid Fee, EMD and Technical bid):

Bid fee (Non-refundable) and EMD as per the tender conditions shall be paid separately, thru RTGS/NEFT transfer in the following HLL A/c details:

Name of Bank : HDFC BANK
A/c number : 09960330000108
IFSC Code : HDFC0000996
Branch name : Pattom, Thiruvananthapuram

Document of the above transactions completed successfully by the Bidder(s), shall be uploaded separately while submitting the bids online.

Technical Bid should contain duly filled, signed and scanned soft copy documents as mentioned in Instructions to Bid (ITB) - Documents to be submitted along with the Technical Bid - Section 7.2.

NOTE

- SSI/MSME units interested in availing exemption from payment of Bid Fee and EMD should submit a valid copy of their registration certificate issued by the concerned DIC or NSIC / Udyog Aadhaar.
- If the Bidder(s) is a MSME, it shall declare in the bid document the Udyog Aadhar Memorandum Number issued to it under the MSMED Act, 2006.
- If a MSME Bidder(s) do not furnish the UAM Number along with bid documents, such MSME unit will not be eligible for the benefits available under Public Procurement Policy for MSEs Order 2012.
- The Party has to provide Security Deposit if the bidder(s) is empanelled as Aggregator(s)
- In case of MSME suppliers who had availed the EMD exemption as per the applicable exemptions, has to submit the equivalent amount of EMD as Security deposit within 7 days from the date of award of empanelment, else the empanelment shall be treated as cancelled.
- HLL Lifecare Limited reserves the right to verify the credential submitted by the bidder at any stage (before or after the award the work). If at any stage, any information / documents submitted by the applicant is found to be incorrect / false or have some discrepancy which disqualifies the firm then HLL shall take the following action
- The bidder shall be liable for debarment from tendering in HLL Lifecare Limited, apart from any other appropriate contractual /legal action.
- On demand of the Tender Inviting Authority, this whole set of certificates and documents shall be send to the Tender Inviting Authority's office address (as given in the notice inviting EOI) by registered post/Speed post of India Post in such a way that it shall be delivered to the Tender Inviting Authority before the deadline mentioned. The Tender Inviting Authority reserves the right to reject any bid, for which the above details are not received before the deadline.
- The Tender Inviting Authority shall not be responsible for any failure, malfunction or breakdown of the electronic system while downloading or uploading the documents by the Bidder(s) during the e-procurement process.

11. Deadline for Submission of the Bids for Interested Bidder(s)

11.1 Bid shall be received only online on or before the date and time as notified in EOI.

11.2 The Tender Inviting Authority, in exceptional circumstances and at its own discretion, may extend the last date for submission of bids, in which case all rights and obligations previously subject to the original date will then be subject to the new date of submission. The Bidder(s) will not be able to submit his bid after expiry of the date and time of submission of bid (server time).

11.3. Resubmission or modification of bid by the Bidder(s) for any number of times before the date and time of submission is allowed. Resubmission of bid shall require uploading of all documents.

11.4.If the Bidder(s) fails to submit his modified bids within the pre-defined time of receipt, the system shall consider only the last bid submitted.

11.5.The Bidder(s) can withdraw his/her bid before the date and time of receipt of the bid. The system shall not allow any withdrawal after the date and time of submission.

12. BID OPENING AND EVALUATION

Bids shall be opened on the specified date & time, by the tender inviting authority or his authorized representative in the presence of Bidder(s) or their designated representatives who choose to attend.

12.1. Bid Opening Process

12.1.1 Opening of bids shall be carried out in the same order as it is occurring in invitation of bids or as in order of receipt of bids in the portal. The Bidder(s) & guest users can view the summary of opening of bids from any system. Bidder(s) are not required to be present during the bid opening at the opening location if they so desire.

Envelope - I: Envelope- I Opening date shall be as mentioned in NOTICE INVITING EOI/EOI Document. (Envelop – I shall contain scanned copy of Bid Fee, EMD and Technical Bid).

If any clarification is needed from Bidder(s) about the deficiency in his uploaded documents in Envelope- I, he will be asked to provide it through CPP portal. The Bidder(s) shall upload the requisite clarification/documents within time specified by HLL Lifecare Limited, failing which tender will be liable for rejection. In extraordinary circumstances the Bidder(s) may be requested to submit the deficient documents intimated through the e-tendering portal additionally by e-mail (As mentioned in the NOTICE INVITING EOI).

12.1.2. In the event of the specified date of bid opening being declared a holiday for HLL, the bids will be opened at the same time on the next working day.

12.2. Confidentiality

12.2.1. Information relating to the examination, clarification, evaluation, and comparison of Bids and recommendations for the award of a contract shall not be disclosed to Bidder(s) or any other persons not officially concerned with such process until the award has been announced in favour of the successful Bidder(s).

12.2.2. Any effort by a Bidder(s) to influence the Purchaser during processing of bids, evaluation, bid comparison or award decisions shall be treated as Corrupt & Fraudulent Practices and may result in the rejection of the Bidder(s)' bid.

12.3 Clarification of Bids

12.3.1. To assist in the examination, evaluation, and comparison of bids, the Tender Inviting Authority may ask the interested Bidder(s) for required clarification on the information submitted with the bid. The request for clarification and the response shall be in writing or by e-mail, but no change in the price or substance of the Bid shall be sought, offered, or permitted.

12.3.2. No Bidder(s) shall contact the Tender Inviting Authority on any matter relating to the submitted bid from the time of the bid opening to the time the contract is awarded. If the Bidder(s) wishes to bring additional information to the notice of the Tender Inviting Authority, he shall do so in writing.

12.4. Examination of Bids, and Determination of Responsiveness

12.4.1. During the bid opening, the Tender Inviting Authority will determine for each Bid whether it meets the required eligibility as specified in the notice inviting EOI and the required documents and certificates.

12.4.2. A substantially responsive bid is one which conforms to all the terms, conditions, and requirements of the bidding documents, without material deviation or reservation.

A material deviation or reservation is one:-

- which affects in any substantial way the scope, quality, or performance of the Works;
 - which limits in any substantial way, inconsistent with the bidding documents, the Purchaser's rights or the Bidder(s)'s obligations under the Contract;
- or
- Whose rectification would affect unfairly the competitive position of other Bidder(s) presenting substantially responsive Bids.

12.4.3. If a Bid is not substantially responsive, it may be rejected by the Tender Inviting Authority, and may not subsequently be made responsive by correction or withdrawal of the nonconforming material deviation or reservation.

12.4.4. Non submission of legible or required documents or evidences may render the bid non-responsive.

12.4.5. Bidder(s) can witness the principal activities and view the documents/summary reports for that particular work by logging on to the portal with his DSC from anywhere.

12.4.6. In case only single bid is received, then the purchaser reserves the right to accept/reject the bid as per prevailing norms of GFR and CPP portal, or to go for retender.

13. BID VALIDITY

Bids shall remain valid for the period of 365 (Three Sixty Five) days from the date of empanelment, which may be extendable upto 2 more years on year to year basis based on satisfactory performance and mutual agreement. A bid valid for a shorter period shall be rejected by HLL as non-responsive.

14. STATUTORY EXEMPTIONS:

- **MSME** - Statutory exemptions as per relevant guidelines shall be applicable for MSE Bidder(s). However, the preferences with respect to MSME shall not be applicable who are only involved the trading of the product under the scope of this tender.
- **PPP MII** - Preferences for Make in India products / services shall be applicable in line with Government Order No.P-45021/12/2017PP (BE-II), 2017 (published by Department for Promotion of Industry and Internal Trade) inclusive of the latest amendments. Self declaration to be submitted to claim MAKE IN INDIA preference.

15. BID SECURITY (EMD)

- i. The Interested Bidder(s) shall furnish, as part of his Bid, a Bid Security for an amount as detailed in the Notice inviting EOI. For e-tenders, Interested Bidder(s) shall remit the Bid Security using the payment options given in e-tender under Government.
- ii. Each bid must be accompanied by E.M.D. Any Bid not accompanied by an acceptable Bid Security (EMD) shall be rejected as non-responsive.
- iii. The Bid Security (EMD) of the unsuccessful Bidder(s) shall become refundable as promptly as possible after finalization of the tender.
- iv. The Bid Security (EMD) of the successful Bidder(s) shall be converted in to security deposit and shall be refunded to the Bidder(s) only after the expiry of the contract.
- v. In the second stage of tendering process, a separate EMD has to be submitted by the empanelled aggregator(s) based on the project value along with each tender. The EMD amount submitted against this EOI can be set off in the subsequent second stage tender
- vi. SSI/MSME units interested in availing exemption from payment of Bid Security as per applicable exemptions should submit a valid copy of their registration certificate issued by the concerned DIC or NSIC/Udyog Aadhaar. But the Party has to provide Security Deposit, if the bidder is empanelled
- vii. The Bid Security may be forfeited:
 - (a) If a Bidder(s):
 - Changes its offer/bid during the period of bid validity or during the validity of the contract.
 - Does not accept the correction of errors
 - (b) In the case of the successful Bidder(s), if the Bidder(s) fails:
 - To sign the Agreement
 - To deliver the material within stipulated time frame as per PO.
 - To accept the Notification of award/Letter of Indent/ Purchase order and/or submit the security deposit.
 - To acknowledge the Notification of award/Letter of Indent/ Purchase order within 5 days from the date of issue by sending the signed copy of the same.
- viii) In such cases the work shall be rearranged at the risk and cost of the selected Bidder(s)
- viii) The Bid Security deposited will not carry any interest.

16. Bid FEE

- 16.1. For e-tenders, the mode of remittance of Bid Fee shall be the same as detailed for remitting Bid Security (EMD). For e-tenders, Interested Bidder(s) shall remit the Bid Fee using the payment options as mentioned in the e-tender in Government eProcurement portal only.

16.2. Any bid not accompanied by the bid fee as notified, shall be rejected as nonresponsive.

16.3. Bid Fee remitted will not be refunded.

17. ALTERATIONS AND ADDITIONS

17.1 The bid shall contain no alterations or additions, except those to comply with instructions, or as necessary to correct errors made by the Bidder(s), in which case such corrections shall be initiated by the person or persons signing the bid.

17.2 The Interested Bidder(s) shall not attach any conditions of his own to the Bid. The Bid quote must be based on the tender documents. Any Bidder(s) who fails to comply with this clause will be disqualified.

18. SECURITY DEPOSIT

18.1. Within 7 days of the receipt of notification of award of empanelment from the purchaser; the successful Bidder(s) shall furnish the security deposit in the form of a Demand Draft or Bank Guarantee.

18.2. The EMD submitted by the successful Bidder(s) shall be converted to Security Deposit and shall be refunded to the Bidder(s) only after the expiry of the contract.

18.3. In case of MSME suppliers who had availed the EMD exemption as per the applicable exemptions, has to submit the equivalent amount of EMD as Security deposit within 7 days from the date of award of empanelment, else the empanelment shall be treated as cancelled. Failure of the successful Bidder(s) to accept the notification of award or submission of security deposit within the time frame shall constitute sufficient grounds for the annulment of the award and forfeiture of the EMD, in which even the purchaser/owner may make the award to the next lowest evaluated Bidder(s) or call for new bids.

19. FORFEITURE OF SECURITY DEPOSIT

If the successful Bidder(s) who fails to supply the ordered material at the rate finalized or execute the work within the timelines and / or supplies only part quantity / partially execute the work or fails to comply with the terms and conditions of the purchase order / work order the security deposit furnished will be forfeited / Bank Guarantee encashed.

20. PAYMENT TERMS

20.1 No Advance payment shall be given.

- **40% of the payable amount will be released within 30 days from the date** of Bill of Lading by HLL
- **57% of payable amount will be released after** receipt of material and acceptance at overseas destination country.
- Remaining **3% of payable amount** will be released after 365 days from the date of receipt of material and acceptance at designated delivery point as mentioned above. The bidder can submit Bank Guarantee towards the 3% performance security against which the balance 3% payment shall be released

20.2 The amount payable shall be released on pro rata basis against completion of each consignment and submission of invoices and other supporting documents

20.3. The amount shall be paid by HLL in Indian Rupees.

20.4. Acceptance of the payment terms without any qualification shall form part of the technical bid. In case the payment terms are not accepted, the bid is likely to be

rejected.

20.5 HLL will make payment to supplier towards the GST amount only after the invoice is uploaded by supplier in GST outward return i.e. GSTR-1 and credit of GST is available (reflected in GSTR-2A) to HLL.

21. DELIVERY TERMS

Bidder(s) should ensure that entire scope of work should be completed within 90 days of issue of Notification of Award /Letter of Intent.

22. DELAY IN DELIVERY OF GOODS

22.1. Delivery of the Goods shall be made by the Supplier in accordance with the time schedule prescribed by the Purchaser in the Notice of award/ Letter of Indent / Purchase order. If at any time during performance of the Contract, the Supplier should encounter conditions impeding timely delivery of the Goods , the Supplier shall promptly notify the Purchaser in writing of the fact of the delay, its likely duration and its cause(s). As soon as practicable after receipt of the Supplier's notice, the Purchaser shall evaluate the situation and may at its discretion extend the Supplier's time for performance, with or without penalty.

If the vendor fails to deliver the entire scope of work even during extended delivery period then the Notice of award/ Letter of Indent / Purchase order shall be short-closed.

22.2. A delay by the Supplier in the performance of its delivery obligations shall render the Supplier liable to the imposition of penalty pursuant to agreement, unless an extension of time is agreed upon pursuant to agreement without the application of liquidated damages. Levying of penalty shall be on a case to case basis.

22.3. In case of delay in supply the clause number 18 in GCC (Liquidated Damage) will be applicable.

22.4. If L1 defaults (fails to deliver goods on time) then the purchaser reserves the right to purchase the goods from an alternate supplier or from market at the risk and cost of supplier and if the purchase happens at a price higher than the ordered rates, the purchaser shall have the right to claim the difference upon whom order was originally placed and supplier will be under obligation to pay the same. The purchaser has the right to forfeit the performance security / Security Deposit in the event of default. In addition the purchaser is entitled to recover the business loss suffered by the purchaser consequent to default for supplying the product.

23. TAXES AND DUTIES

The Bidder(s) shall bear and pay all taxes, duties, levies, GST and charges assessed on the Bidder(s) by all municipal, state, or national government authorities, loading & unloading charges etc in connection with the Goods and Services supplied under the Contract. Income Tax and Other Taxes as applicable at the time of execution of job or any other government-imposed liabilities would be deducted from each bill submitted by the Bidder(s)

24. INSPECTION AND TESTS

24.1. The Purchaser or its representative shall have the right to inspect and/or to test the Goods to confirm their conformity to the Contract at no extra cost of the Purchaser. The Special conditions of Contract and/or the Technical Specifications shall specify what

inspections and tests the Purchaser requires and where they are to be conducted. The Purchaser shall notify the Supplier in writing of the identity of any representatives retained for these purposes.

24.2. The inspections and test may be conducted on the premises of the Supplier or at the Goods final destination. Where conducted on the premises of the Supplier or its subcontractor(s), all reasonable facilities and assistance including access to drawings and production data - shall be furnished to the inspectors at no charge to the Purchaser.

24.3. Should any inspected or tested Goods fail to conform to the specifications, the Purchaser may reject them and the Supplier shall either replace the rejected Goods or make all alternations necessary to meet specification requirements free of cost to the Purchaser.

24.4. The Purchasers right to inspect, test and, where necessary, reject the Goods' arrival in at any site shall in no way be limited or waived by reason of the Goods having previously been inspected, tested and passed by the Purchaser or its representative prior to the Goods dispatched.

24.5. HLL reserves the right to seek samples of the product being offered before placement of order and based on approval of samples by HLL/Ultimate customer the order shall be placed. If the sample is rejected due to quality/technical reasons, HLL reserves the right to approach the next higher Bidder(s) for samples and if approved, HLL shall proceed with order placement with the next higher Bidder(s). The samples approved only be accepted against the order placed and any deviation would result in the rejection of the product supplied.

24.6. The supplier should submit the lab reports for the supplies made to HLL. The purchaser reserves the right to sample check the consignment at the time of delivery for which cost shall be borne by the supplier (pre-dispatch inspection). HLL may analyse the sample drawn from the goods received at depots/C&FAs. In case of sample testing failure at third party lab/ HLL's lab or quality related market complaints, the supplier shall take sole responsibility to replace the entire batch free of cost including the freight charges for collecting back the rejected items from HLL warehouses & resupply or refund the payment for such rejected quantity equal to its Door delivery value if the payment is already made.

25. INDEMNITY

The Interested Bidder(s) shall indemnify, defend and hold harmless Government of India and HLL, its Affiliates, officers, directors, employees, agents, and their respective successors and assigns, from and against any and all loss, damage, claim, injury, cost or expenses (including without limitation reasonable attorney's fees), incurred in connection with third Party claims of any kind that arise out of or are attributable to (i) Manufacturer's/Bidder(s) breach of any of its warranties, representations, covenants or obligations set forth herein or (ii) the negligent act or omission of the Manufacturer /Bidder(s).(iii) any product liability claim arising from the gross negligence or bad faith of, or intentional misconduct or intentional breach of this Contract by Bidder(s) or its affiliate. The Bidder(s) has to submit the indemnity certificate duly signed and sealed in the format provided in Annexure 05

26. SHORT SUPPLY:

If any shortages in sealed boxes are detected, then supplier should be held responsible. In such a case, the supplier will have to make good of the loss or refund the payment for such quantity equal to its purchase value if the payment is already made. If the payment is not

made, purchaser will have right to deduct the payment for the equivalent purchase value corresponding to quantity found short.

27. PARALLEL RATE CONTRACTS:

HLL reserves the right to enter into the rate contract / parallel rate contracts with one or more parties or to place adhoc contracts simultaneously or at any time during the currency of contract, with one or more suppliers.

The purchaser also reserves the rights (1) to enter into parallel Price Agreement(s)/Contract(s) simultaneously or at any time during the period of the Price Agreement/Rate Contract with one or more Bidder(s) as he/they think fit and (2) to place adhoc contract or contracts simultaneously or at any time during the period of this Rate contract with one or more supplier(s) / Bidder(s) for such quantity of such item or items as the purchaser (whose decision shall be final) may determine.

28. IN CASE OF DEFAULT

The purchaser is not bound to accept the L1 offer only and circumstances warranting where L1 shows its disinterest, L2 or higher offer may be considered for acceptance.

29. RISK PURCHASE

If L1 or any other parties' defaults (fails to deliver goods on time) then the purchaser reserves the right to purchase the goods from an alternate supplier or from market at the risk and cost of L1 supplier and if the purchase happens at a price higher than the ordered rates, the purchaser shall have the right to claim the difference upon whom order was originally placed and L1 supplier will be under obligation to pay the same. In addition, the purchaser is entitled to recover the business loss suffered by the purchaser consequent to default for supplying the product.

30. FORCE MAJEURE

30.1 For purposes of this Clause "Force Majeure" means an event beyond the control of the Supplier and not involving the Supplier's fault or negligence and not foreseeable. Such events may include, but are not limited to, acts of the Purchaser either in its sovereign or contractual capacity, wars or revolutions, fires, floods, epidemics, quarantine restrictions and freight embargoes.

30.2 If a Force Majeure situation arises, the Supplier shall promptly notify the Purchaser in writing within Seven days from the date of such conditions and the cause thereof. Unless otherwise directed by the Purchaser in writing, the Supplier shall continue to perform its obligations under the Contract as far as is reasonably practical, and shall seek all reasonable alternative means for performance not prevented by the force majeure event.

31. GOODS REPLACEMENT:

If goods are found to be defective during the sample testing by HLL or Quality related market complaint, on arrival of the material at designated HLL delivery point, supplier must replace the quantity free of cost with fresh batch upon demand by HLL. However replacement of goods will be accepted by HLL subject to the concurrence from the ordering institute else the purchase order will be cancelled and Clause 24 (Delay in delivery of goods) will be applied under the discretion of HLL.

32. CLARIFICATIONS ON BIDS- INTERESTED BIDDER(S)

During the bid evaluation, HLL may, at its discretion, ask the Bidder(s) for a clarification of its bid. The request for clarification and the response shall be in writing, and no change in the price or substance of the bid shall be sought, offered, or permitted

33. CONTACTING HLL

- a) From the time of bid opening to the time of Contract award, if any Bidder(s) wishes to contact HLL on any matter related to the bid, he shall do so in writing by sending email to sdrbdsouth@lifecarehll.com.
- b) If a Bidder(s) tries to influence HLL directly or otherwise, interfere in the bid evaluation process and the Contract award decision, his bid will be rejected.

34. HLL'S RIGHT TO ACCEPT OR REJECT ANY OR ALL BIDS

The Purchaser reserves the right to accept or reject any bid, and to annul the bidding process and reject all bids at any time prior to award Contract award, without thereby incurring any liability to the affected Bidder(s) or Bidder(s).

The purchaser does not bind itself to accept the lowest or any bid and reserves the right to reject any or all bids at any point of time prior to the issuance of the Notice of award/Letter of intent/Purchase order without reason whatsoever.

The purchaser reserves the right to resort to retendering without providing any reasons whatsoever. The purchaser shall not incur any liability on account of such rejection.

The purchaser reserves the right to modify any terms, conditions or specifications for submission of offer and to obtain revised bids from the Bidder(s) due to such changes, if any.

Canvassing of any kind will be a disqualification and the purchaser may decide to cancel the Bidder(s) from its empanelment.

The purchaser reserves the right to accept or reject any bid and annul the bidding process and reject all bids at any time prior to award of contract without thereby incurring any liability to the affected Bidder(s) or Bidder(s) or any obligation to inform the affected Bidder(s) or Bidder(s) of the ground for the purchaser's action.

35. PURCHASER'S RIGHT TO VARY QUANTITIES AT TIME OF AWARD

The Purchaser reserves the right at the time of award of contract to increase or decrease the quantity of goods and services originally specified in the bid document without any change in unit price or other terms and conditions.

36. SETTLEMENT OF DISPUTES

Arbitration shall not be a means of settlement of any dispute or claim arising out of the contract relating to the work. Any disputes or difference arising between the parties with respect to the performance of any part of this agreement or anything connected therewith, etc shall as far as possible be mutually settled by the process of dialog and negotiation. Any disputes or differences or questions or claims arising under or relating to a concerning or touching this agreement shall be referred for arbitration in accordance with the provisions of

the Arbitration and Conciliation Act 1996.

The arbitration proceedings shall be held at Thiruvananthapuram. The award passed by the arbitrator shall be final and binding on the parties hereto. The conduct of such arbitration shall be in English. Subject to arbitration, the Courts at Thiruvananthapuram alone shall have jurisdiction in respect of settlement of any matter arising out or in connection with the contract.

37. GOVERNING LANGUAGE

The contract shall be written in English language. English language version of the Contract shall govern its interpretation. All correspondence and documents pertaining to the Contract which are exchanged by the parties shall be written in the same language.

38. NOTIFICATION OF AWARD

Prior to the expiration of the period of bid validity, the eligible Bidder(s) shall be empanelled. Purchaser shall notify the successful Bidder(s) accordingly.

39. TERMINATION

HLL reserve right to terminate/ cancel the Notification of award/ Letter of Indent/ Purchase order at any time for any reason without any liability on HLL.

40. FALL CLAUSE

The BIDDER(S) undertakes that it has not supplied/is not supplying similar product/systems or subsystems OR providing similar services at a price/ charge lower than that offered in the present bid in respect of any other Ministry/Department of the Government of India or PSU and if it is found any stage that similar product/systems or sub systems was supplied by the BIDDER(S) to any to the Ministry/Department of the Government of India or a PSU at a lower price, then that very price, with due allowance for elapsed time will be applicable to the present case and the difference in the cost would be refunded by the BIDDER(S) to HLL, if the contract has already been concluded.

41. CORRUPT OR FRAUDULENT PRACTICES

The purchaser requires that the Bidder(s), suppliers and contractors observe the highest standard of ethics during the procurement and execution of such contracts. In pursuit of this policy, the following are defined:

Sl. No	Term	Meaning
(a)	Corrupt practice	The offering, giving, receiving, or soliciting, directly or indirectly, of anything of value to influence the action of a public official in the procurement process or in contract execution.
(b)	Fraudulent practice	A misrepresentation or omission of facts in order to influence a procurement process or the execution of a contract.
(c)	Collusive practice	Means a scheme or arrangement between two or more Bidder(s), with or without the knowledge of the purchaser, designed to establish bid prices at artificial, non-competitive levels.
(d)	Coercive practice	Means harming or threatening to harm, directly or indirectly,

		persons or their property to influence their participation in the procurement process or affect the execution of a contract.
--	--	--

The Purchaser will reject the proposal for award if it determines that the Bidder(s) recommended for award has, directly or through an agent, engaged in corrupt, fraudulent, collusive or coercive practices in competing for the Contract in question.

42. SHELF LIFE

The supplies of all products should be from fresh stock only. For items having shelf life, at the time of receipt, they should have the latest manufacturing date with minimum 75% of the shelf life remaining. Products to be supplied should be of standard quality/quantity as per specification and must be as per the formulations/standard approved/specified by the Drug Control Act and Food & Drug Control Administration Regulation or as per the regulation of any such statutory authorities.

43. FLEXIBILITY OF PRICES

The purchaser has option to re-negotiate with rate contract holder to bring down the rate contract prices whenever market fluctuations affect the prices abnormally.

44. LICENSE AND PERMITS

The Supplier shall acquire in its name all permits, approvals, and/or licenses from all local, state, or national government authorities or public service undertakings that are necessary for the performance of the Contract.

The Supplier shall comply with all laws in force in India. The laws will include all national, provincial, municipal, or other laws that affect the performance of the Contract and are binding upon the Supplier. The Supplier shall indemnify and hold harmless Purchaser from and against any and all liabilities, damages, claims, fines, penalties, and expenses of whatever nature arising or resulting from the violation of such laws by the Supplier or its personnel.

45. INTEGRITY PACT

Pre-Contract Integrity Pact and Independent External Monitor

The Integrity pact annexed shall be part and parcel of this document, and has to be signed by Bidder(s) at the pre-tendering stage itself, as a pre bid obligation and should be submitted along with the financial and technical bids. All the Bidder(s) are bound to comply with the Integrity Pact clauses. Bids submitted without signing Integrity Pact will be ab initio rejected without assigning any reason.

The Integrity pact annexed shall be part and parcel of this document, and has to be signed by Bidder(s) at the pre-tendering stage itself, as a pre-bid obligation and should be submitted along with the financial and technical bids. All the Bidder(s) are bound to comply with the Integrity Pact clauses. Bids submitted without signing Integrity Pact will be ab initio rejected without assigning any reason.

The email id of the Independent External Monitor for HLL is given below.

Email id: jemhll@lifecarehll.com

46. RESTRICTIONS UNDER RULE 144 (XI) OF GFR 2017 FOR BIDDER(S) FROM COUNTRY SHARING LAND BORDER WITH INDIA.

Any Bidder(s) from a country which shares a land border with India will be eligible to bid in this tender only if the Bidder(s) is registered with Competent Authority, as per order no F.No.6/18/2019-PPD dated 23-July-2020 (Rule 144 (xi) of GFR) inclusive of the latest amendments issued by Ministry of Finance, GOI at Appendix of this bidding document. The

Bidder(s) must comply with all provisions mentioned in this order. A self-declaration (as per format provided in Annexure 08) with respect to this order must be submitted.

47. PURCHASE PREFERENCE TO MICRO AND SMALL ENTERPRISES (MSE's)

Purchase preference will be given to MSEs as defined in Public Procurement Policy for Micro and Small Enterprises (MSEs) Order, 2012 dated 23.03.2012 issued by Ministry of Micro, Small and Medium Enterprises and its subsequent Orders/Notifications issued by concerned Ministry. However, the preferences with respect to MSME shall not be applicable who are only involved the trading of the product under the scope of this tender.

48. PROVISIONS OF PUBLIC PROCUREMENT (PREFERENCE TO MAKE IN INDIA) ORDER 2017

Statutory exemptions as per relevant guidelines shall be applicable for MSE Bidder(s). Preferences for Make in India products / services shall be applicable in line with Government Order No.P-45021/12/2017PP (BE-II), 2017 (published by Department for Promotion of Industry and Internal Trade) inclusive of the latest amendments. Self-declaration to be submitted to claim MAKE IN INDIA preference as per Annexure 09.

49. SPLITTING OF ORDER

In case of critical/vital/safety/security nature of the item, large quantity under procurement, urgent delivery requirements and inadequate vendor capacity, HLL reserves the right to split the contract quantity between the Bidder(s)s. The splitting ratio shall be 50:30:20. The lowest rate accepted would be counter offered to the L2 party. On acceptance of the counter offer, the order will be placed on L2 for the respective percentage. In case of non-acceptance of the counter offer by the L2 party, a similar offer shall be made to L3 and L4, and so on.

GENERAL CONDITIONS OF CONTRACT (GCC)

1. DEFINITIONS

1.1 In this contract the following terms shall be interpreted as indicated:

- (a) "The Contract" means the agreement entered into between the Purchaser and the Supplier as recorded in the Contract Form signed by the parties, including all the attachments and appendices thereto and all documents incorporated by reference therein;
- (b) "The Contract Price" means the price payable to the Supplier under the Contract for the full and proper performance of its contractual obligations;
- (c) "The Goods" means all the products, and/or other materials which the Supplier is required to supply to the Purchaser under the Contract;
- (d) "Services" means services ancillary to the supply of the Goods, such as transportation and insurance, and other incidental services, covered under the contract;
- (e) "GCC" means the General Conditions of Contract contained in this section.
- (f) "SCC" means the Special Conditions of Contract.
- (g) "The Purchaser" means the Organisation purchasing the Goods, as named in SCC;
- (h) "The Supplier" means the individual or firm supplying the Goods under this Contract;
- (i) "Day" means calendar day.
- (j) "Delivery period" means the period applicable upto completion of supply of goods by the supplier at the required site mentioned in Notification of award/ Letter of Indent/ Purchase order and accepted by the Purchaser.

2. APPLICATION

2.1 These General Conditions shall apply to the extent that they are not superseded by provisions in other parts of the Contract.

3. STANDARDS

3.1 The Goods supplied under this Contract shall conform to the standards mentioned in the Technical Specifications.

4. USE OF CONTRACT DOCUMENTS AND INFORMATION

- 4.1 The Supplier shall not, without the Purchaser's prior written consent, disclose the Contract, or any provision thereof, or any specification, plan, drawing, pattern, sample or information furnished by or on behalf of the Purchaser in connection therewith, to any person other than a person employed by the Supplier in performance of the Contract. Disclosure to any such employed person shall be made in confidence and shall extend only so far as may be necessary for purposes of such performance.
- 4.2 The Supplier shall not, without the Purchaser's prior written consent, make use of any document or information enumerated in GCC Clause 4.1 except for purposes of performing the Contract.
- 4.3 Any document, other than the Contract itself, enumerated in GCC clause 4.1 shall remain the property of the Purchaser and shall be returned (in all copies) to the Purchaser on completion of the supplier's performance under the Contract if so required by the Purchaser.

5. SUBCONTRACTS

The supplier shall notify the Purchaser in writing of all subcontracts awarded under the contract if not already specified in his bid. Such notification, in his original bid or

later, shall not relieve the Supplier from any liability or obligation under the contract.

6. CONTRACT AMENDMENTS

6.1 Subject to GCC Clauses, no variation in or modification of the terms of the Contract shall be made except by written amendment signed by the parties.

7. PATENT RIGHTS

7.1 The Supplier shall indemnify the Purchaser against all third-party claims of infringement of patent, trademark or industrial design rights arising from use of the Goods or any part thereof in India.

7.2 Any product related cases shall be handled and connected expenses therewith shall be borne by the Supplier only.

8. INSURANCE

For delivery of goods at site, the insurance shall be obtained by the Supplier in an amount equal to 110% of the value of the goods from “Warehouse to Warehouse” (Final destinations) on “All Risks” basis including War Risks and Strike.

9. CHANGE ORDERS

9.1 The Purchaser may at any time by written order given to the Supplier, make changes within the general scope of the Contract in any one or more of the following:

- (a) The method of shipping or packing
- (b) The place of delivery; or
- (c) The services to be provided by the Supplier.

10. ASSIGNMENT

10.1 The Supplier shall not assign, in whole or in part, its obligations to perform under the contract, except with the Purchaser’s prior written consent.

11. TERMINATION BY DEFAULT

11.1 The Purchaser may, without prejudice to any other remedy for breach of contract, by written notice of default sent to the supplier, terminate the Contract in whole or part;

- (a) if the Supplier fails to deliver any or all of the goods within the time period(s) specified in the Contract, or within any extension thereof granted by the Purchaser, or
- (b) If the Supplier fails to perform any other obligation(s) under the contract.

11.2 In the event the Purchaser terminates the Contract in whole or in part, the Purchaser may procure, upon such terms and in such manner as it deems appropriate, Goods or Services similar to those undelivered, and the Supplier shall be liable to the Purchaser for any excess costs for such similar Goods. However, the Supplier shall continue the performance of the Contract till such time.

12. TERMINATION FOR INSOLVENCY

The Purchaser may at any time terminate the Contract by giving written notice to the Supplier, if the Supplier becomes bankrupt or otherwise insolvent. In this event, termination will be without compensation to the Supplier, provided that such termination will not prejudice or affect any right of action or remedy which has accrued or will accrue thereafter to the Purchaser.

13. APPLICABLE LAW

The Contract shall be interpreted in accordance with the laws of the Union of India.

14. NOTICES

- 14.1 Any notice given by one party to the other pursuant to this Contract shall be sent to other party in writing or by cable, telex or facsimile and confirmed in writing to the other Party's address specified in Special Conditions of Contract.
- 14.2 A notice shall be effective when delivered or on the notice's effective date, whichever is later.

15. TAXES AND DUTIES

Supplier shall be entirely responsible for all taxes, duties, license fees, octroi etc., incurred until delivery of the contracted Goods to the Purchaser.

16. PACKING

- 16.1 The Supplier shall provide such packing of the Goods as is required to prevent their damage or deterioration during transit to their final destination as indicated in the Contract. The packing shall be sufficient to withstand, without limitation, rough handling during transit and exposure to extreme temperatures, salt and precipitation during transit and open storage. Packing case size and weights shall take into consideration, where appropriate, the remoteness of the Goods final destination and the absence of heavy handling facilities at all points in transit. Packing shall adhere to conditions stipulated in Technical specification.
- 16.2 The packing, marking and documentation within and outside the packages shall comply strictly with such special requirements as shall be provided for in the Contract including additional requirements, if any, specified in SCC and in any subsequent instructions ordered by the Purchaser

17. DELIVERY AND DOCUMENTS

Delivery of the Goods shall be made by the Supplier in accordance with the terms specified by the Purchaser in the Letter of Indent / Notification of Award / Purchase order. The details of dispatching and/or other documents to be furnished by the Supplier are specified in SCC, if any.

18. LIQUIDATED DAMAGES

If the Supplier fails to deliver any or all of the Goods or perform of services within the time period(s) specified in the Contract, the Purchaser shall without prejudice to its other remedies under the Contract, deduct from the Contract Price, as liquidated damages, a sum equivalent to 0.5 percent of the delivered price of the delayed Goods or unperformed Services for each week of delay or part thereof until actual delivery or performance, up to a maximum deduction of 10 percent of the delayed Goods or Services contract price. Service tax as applicable will also be recovered in addition to the liquidated damages. However, H.L.L at its sole discretion reserves the right to accept or reject the delivery of materials which are supplied beyond the delivery date as mentioned in the purchase order. In the event of H.L.L accepting the delivery of the materials beyond the stipulated delivery date as per the Purchase order, penalty as mentioned above would apply. In the event of H.L.L rejecting the delivery of the materials beyond the stipulated delivery date as per the Purchase order, then the party is liable to repay HLL any advance amount which was paid by HLL, failing which HLL will have the right to initiate legal proceedings against such party/ successful Bidder(s). Once the maximum is reached, the Purchaser may consider termination of the Contract. If the Supplier fail to comply with specific packing descriptions or instructions, the loss incurred by the purchaser on this account shall be indemnified by the supplier.

19. RESOLUTION OF DISPUTES

- 19.1 The Purchaser and the Supplier shall make every effort to resolve amicably by direct informal negotiation any disagreement or dispute arising between them under or in connection with the Contract.

19.2 If, after thirty (30) days from the commencement of such informal negotiations, the Purchaser and the Supplier have been unable to resolve amicably a Contract dispute, either party may require that the dispute be referred for resolution to the formal mechanisms specified in the Special Conditions of Contract. These mechanisms may include, but or not limited to, conciliation mediated by a third Party, adjudication in an agreed national forum, and national arbitration.

Special Conditions of Contract (SCC)

The following Special Conditions of Contract (SCC) will apply for this purchase. The corresponding clauses of General Conditions of Contract (GCC) relating to the SCC stipulations have also been incorporated below.

These Special Conditions will modify/substitute/supplement the corresponding (GCC) clauses.

Whenever there is any conflict between the provision in the GCC and that in the SCC, the provision contained in the SCC shall prevail.

There are no special conditions or contract for this tender and all other conditions mentioned in other sections stands valid.

SELF - DECLARATION

Tender: Empanelment of Aggregators for the Supply of Aluminum Cuboids and other products as per Customized Packaging for onward supplies to Overseas countries

Tender No. HLL/SD/RBD/2022-23/EOI/11

To,
Vice President (Sourcing)
HLL Lifecare Limited,
HLL Bhavan, Poojappura,
Thiruvananthapuram -695012 Kerala, India
Tel: 0471 2775500, 0471 2358151 (EXTN – 600/606/531)

Dear Sir,

We certify that We or our Principal Manufacturer (if applicable), have not been de-registered or debarred or blacklisted or banned / suspended for business for any product or constituent of the product we have quoted, by State Government / Central Govt. Organization /State Medical Corporations/ Director Health Services and or convicted by any court of law, till the due date of submission of BID as specified in the subject BID. If we, at a later date, are found guilty of suppressing facts in this regard, such act on our part shall be considered a fraudulent practice in accordance with the Instructions to Bidder(s) and the Purchaser shall be entitled to reject our BID for the product quoted, submitted by us against this Tender.

Also certify that the quoted products possess relevant quality assurance certification issued by the concerned authorities for all the offered products.

We hereby guarantee that the drugs supplied by our company are not spurious and we further guarantee not to supply any sub-standard or spurious drugs. We assure that the drugs/medicines to be supplied shall be as per the formulations / standard approved / specified by the Drug Control Act and Food & Drug Control Administration Regulation or as per the regulation of any such statutory authorities.

We have also noted that after submission of BID and before award contract, if we are deregistered or debarred or blacklisted by State Government or Government of India / Drug Controller, our BID will be considered as Non-responsive.

We hereby declare that the facts furnished for the purpose of this tender are correct and true to the best of our knowledge. We are well aware that any discrepancy in the same makes us liable for disqualification / debarment / appropriate action by the tenderer.

Date:
Place:

Signature:
Name:
Designation:
Seal:

BID FORM

Ref:

Date:

To,

Vice President (Sourcing)
HLL Lifecare Limited,
HLL Bhavan, Poojappura,
Thiruvananthapuram -695012 Kerala, India
Tel: 0471 2775500, 0471 2358151 (EXTN – 600/606/531)

Dear Sir,

Tender: Empanelment of Aggregator for collaborating with HLL for Supply of Pharmaceutical products/ Surgical items / Equipment for onward supplies to Overseas country.

Tender No. HLL/SD/RBD/2022-23/EOI/11

Having examined the Bidding Documents, including Addenda Nos. [insert numbers], the receipt of which is hereby acknowledged, we, the undersigned, offer our services in full conformity with the Bidding Documents.

We undertake that in case our bid is accepted, we shall Commence work and shall make all reasonable endeavour to achieve contract acceptance.

We agree to abide by this bid, which, in accordance with consists of this letter, letter of authorization, documents establishing conformity, and Attachments through [specify: the number of attachments] to this Bid Form, 365 days from the date of empanelment which may be extendable upto 2 more years on year to year basis based on satisfactory performance and mutual agreement and it shall remain binding upon us and may be accepted by you at any time before the expiration of that period.

In case a formal final Contract is not prepared and executed between us, this bid, together with your written acceptance of the bid and your notification of award, shall constitute a binding contract between us. We understand that you are not bound to accept the lowest or any bid you may receive.

We, the Bidder(s) shall indemnify, defend and hold harmless Government of India, HLL, its Affiliates, officers, directors, employees, agents, and their respective successors and assigns, from and against any and all loss, damage, claim, injury, cost or expenses (including without limitation reasonable attorney's fees), incurred in connection with third Party claims of any kind that arise out of or are attributable to (i) Manufacturer's/Bidder(s) breach of any of its warranties, representations, covenants or obligations set forth herein or (ii) the negligent act or omission of the Manufacturer/Bidder(s). (iii) any product liability claim arising from the gross negligence or bad faith of, or intentional misconduct or intentional breach of this Contract by Bidder(s) or any affiliate.

We agree to all terms and conditions of the Bid Document and subsequent amendments.

Dated this [insert: number] day of [insert: month], [insert: year].

Signature.....

Name.....

Full Address with contact person Name, Phone number and Email
Designation and Common Seal...

Annexure-03

UNDERTAKING LETTER FOR REPLACEMENT OF COMPLAINT/DEFECTIVE GOODS

Tender: Empanelment of Aggregators for the Supply of Aluminum Cuboids and other products as per Customized Packaging for onward supplies to Overseas countries

Tender No. HLL/SD/RBD/2022-23/EOI/11

To,

Vice President (Sourcing)
HLL Lifecare Limited,
HLL Bhavan, Poojappura,
Thiruvananthapuram -695012 Kerala, India
Tel: 0471 2775500, 0471 2358151 (EXTN – 600/606/531)

Dear Sir,

We hereby confirm and assure you, that the products supplied by us will meet all the quality standards and even if any quality complaint arises, we (name-----) take the responsibility to take back the complaint batches and replace and deliver fresh batch to HLL stores/ warehouse free of cost within 30 days. We (name----) shall also bear the transportation charges for collecting back the compliant/rejected batches or goods and the transportation charges incurred for making the replacement.

Signature_____

Name_____

Designation and Common Seal

Station_____

Date_____

Tender: Empanelment of Aggregators for the Supply of Aluminum Cuboids and other products as per Customized Packaging for onward supplies to Overseas countries

Tender No. HLL/SD/RBD/2022-23/EOI/11

Category details of organization

SL No.	Description	Yes/No
1.	*Whether the organization belongs to the MSME category	
2.	*If yes whether the organization belongs to MSE category	
3.	*Whether the MSE organization belongs to SC/ST entrepreneur.	
4.	*Whether the MSE organization belongs to woman entrepreneur.	
5	Whether the MSE organization is registered under MSE Type of Enterprise ' Manufacturer '	

***Kindly furnish the copies of documents supporting your above claim along with this Annexure duly filled.**

***The Udyog Aadhar no of the Bidder(s)**

(Self-attested copy of Udyog Aadhar registration certificate should be submitted along with the technical bid)

Date:

Signature of the Bidder(s):

Place:

Name with seal:

Designation:

Address:

Annexure 05

To,

Vice President (Sourcing)
HLL Lifecare Limited,
HLL Bhavan, Poojappura,
Thiruvananthapuram -695012 Kerala, India
Tel: 0471 2775500, 0471 2358151 (EXTN – 600/606/531)

Tender: Empanelment of Aggregators for the Supply of Aluminum Cuboids and other products as per Customized Packaging for onward supplies to Overseas countries

Tender No. HLL/SD/RBD/2022-23/EOI/11

INDEMNITY CERTIFICATE

Dear Sir,

As a supplier to HLL, the indemnifier assumes liability for and irrevocably agrees to indemnify, defend and hold harmless Government of India and HLL Lifecare Limited, its Affiliates, shareholders, officers, directors, employees, agents, and their respective successors and assigns from and against any and all losses, damages, claims, actions, liabilities, proceedings, injury, cost or expenses (including counsel's fees of whatsoever kind of nature arising out of or in any way connected with the licenses granted or the manufacture of the products or out of any defect (whether obvious or hidden) in the products or arising from the indemnifier's failure to comply with applicable laws.

Dated this [insert: number] day of [insert: month], [insert: year].

Signature.....

Name.....

Full Address with contact person Name, Phone number and Email

Designation and Common Seal...

Performance Bank Guarantee Format

To: _____ (Name of Purchaser)
WHEREAS _____ (Name of Supplier) (hereinafter called "the Supplier")
has undertaken, in pursuance of Contract No. _____ dated
_____ 20____ to supply _____ (Description of Goods and Services)
(hereinafter called "the Contract").

AND WHEREAS it has been stipulated by you in the said Contract that the Supplier shall furnish you with a Bank Guarantee by a recognized bank for the sum specified therein as security for compliance with the Supplier's performance obligations in accordance with the Contract.

AND WHEREAS we have agreed to give the Supplier a Guarantee:

THEREFORE WE hereby affirm that we are Guarantors and responsible to you, on behalf of the Supplier, up to a total of _____ (Amount of the Guarantee in Words and Figures) and we undertake to pay you, upon your first written demand declaring the Supplier to be in default under the Contract and without cavil or argument, any sum or sums within the limit of _____ (Amount of Guarantee) as aforesaid, without your needing to prove or to show grounds or reasons for your demand or the sum specified therein.

This guarantee is valid until the _____ day of _____ 20____.

Signature and Seal of Guarantors

Date: _____ 20 _____

Address: _____

Annexure 07
Tender: Empanelment of Aggregators for the Supply of Aluminum Cuboids and other products as per Customized Packaging for onward supplies to Overseas countries
Tender No. HLL/SD/RBD/2022-23/EOI/11
CHECK LIST

SI No	PARTICULAR OF DOCUMENT	ATTACHED / NOT ATTACHED	PAGE NO	Remarks
1	Forwarding letter indicating the submission of Technical documents along with check list of document			
2	EMD/ Bid Fee - copy of the NEFT/RTGS details			
3	Tender document duly signed and stamped in all pages along with corrigendum (if Any)			
4	Authenticated copy of the Memorandum of Association/Articles of Association / Partnership deed etc and certificates of incorporation/ registration of the organization with details of Name, Address, Tel. No., Fax No., E-mail Address of firm and the M. Director / Partner / Proprietor			
5	Documentary proof attested by Chartered Accountant for establishing the average annual turnover of Bidder(s) having a minimum average annual turnover of Rs.40 Crores (Rupees Forty Crores only) during the last three years i.e. 2019-20, 2020-2021 and 2021-2022 (original/ provisional).			
6	Last three years Purchase orders received from CentralGovts/StateGovts/PSUs/Autonomous agencies/other institutions to prove the experience in procurement/supplying/Distribution of Pharmaceutical/surgical/ equipment. Copy of work orders in support of their claims during the preceding three years ie 2019-20. 2020-21 & 2021-22 shall be uploaded.			
7	Copy of Recent Non conviction certificate to the effect that the bidder has not been convicted during the preceding three years and that no case / proceedings is pending against the manufacturer in any Court of Law in India			
8	Power of Attorney in stamp paper (RS.200/-) duly notarized authorizing the signatory to sign the bids and transact business.			
9	Annexure 1 - Self Declaration			
10	Annexure 2 - Bid Form			
11	Annexure 3 - Under taking letter for replacement of complaint/defective goods			
12	Annexure 4 – Category details of Organization			
13	Annexure 5 - Indemnity Certificate			
14	Annexure 7 - Check List			
15	Annexure 8- Compliance To Rule 144 (XI) of GFR 2017 (Self Declaration)			
16	Annexure 9 - Make In India Preference (Self Declaration)			
17	Annexure 10 – Pre Contract Integrity Pact			
18	Copy of PAN Card			
19	Copy of Udyog Aadhaar, in case of MSME Bidder(s)			
20	Copy of GST Certificate			

Tender: Empanelment of Aggregators for the Supply of Aluminum Cuboids and other products as per Customized Packaging for onward supplies to Overseas countries

Tender No. HLL/SD/RBD/2022-23/EOI/11

SELF DECLARATION – COMPLIANCE TO RULE 144 (XI) OF GFR 2017

We,

.....
.....
.....

(Include name and address of the Bidder(s))

Hereby declare that we are eligible to bid for the tender:

(Include tender number and date)

As per the eligibility stipulated by Government Order no F.No.6/18/2019-PPD dated 23-July-2020 inclusive of the latest amendments regarding insertion of rule 144(Xi) in the General Financial Rules (GFR) 2017, issued by Ministry of Finance, Government of India.

We are aware that any Bidder(s) indenting to participate in this tender who is from a country which shares a land border with India will be eligible to bid in this tender only if the Bidder(s) is registered with Competent Authority as per the GO.

Date:

Signature of the Bidder(s):

Place:

Name with seal:

Designation:

Address:

Annexure 09

Tender: Empanelment of Aggregators for the Supply of Aluminum Cuboids and other products as per Customized Packaging for onward supplies to Overseas countries

Tender No. HLL/SD/RBD/2022-23/EOI/11

SELF DECLARATION – MAKE IN INDIA PREFERENCE

In line with Government Public Procurement Order No. P-45021/2/2017-BE-II dt. 15.06.2017, as amended from time to time and as applicable on the date of submission of tender, we hereby certify that we M/s_____ (supplier name) are local supplier meeting the requirement of minimum Local content (50%) as defined in above orders for the material _____ against _____ Tender No _____ Details of location at which local value addition will be made is as follows: -----

----- We also understand, false declarations will be in breach of the Code of Integrity under Rule 175(1)(i)(h) of the General Financial Rule for which for which a Bidder(s) or its successors can be debarred for up two years as per Rule 151 (iii) of the General Financial Rules along with such other actions as may be permissible under law.

Seal and Signature of Authorized Signatory

PRE-CONTRACT INTEGRITY PACT

This Pre-Contract Integrity Pact (herein after called the Integrity Pact) is made on -----^t day of the month of -----,

Between

HLL Life Care Limited, a Government of India Enterprise with registered office at HLL Bhavan, Poojappura, Thiruvananthapuram 695 012, Kerala, India. (Hereinafter called “HLL”, which expression shall mean and include, unless the context otherwise requires, his successors in office and assigns) of the First Party.

And

----- India represented by Shri -----
(hereinafter called the “BIDDER(S) / Seller” / Contractor which expression shall mean and include, unless the context otherwise requires, his successors and permitted assigns) of the Second Party.

Preamble

[Both HLL and BIDDER(S) referred above are jointly referred to as the Parties]

HLL intends to award, under laid down organizational procedures, Purchase orders / contract/s against Tender /Work Order. HLL desires full compliance with all relevant laws and regulations, and the principles of economic use of resources, and of fairness and transparency in its relations with its Bidder(s)/s and Contractor/s.

NOW, THEREFORE,

To avoid all forms of corruption by following a system that is fair, transparent and free from any influence /prejudiced dealings prior to, during and subsequent to the currency of the contract to be entered into with a view to:-

1. Enable HLL to obtain the desired materials/ stores/equipment/ work/ project done at a competitive price in conformity with the defined specifications by avoiding the high cost and the distortionary impact of corruption on public procurement; and
2. Enable the BIDDER(S) to abstain from bribing or indulging in any corrupt practice in order to secure the contract by providing assurance to them that their competitors will also abstain from bribing and other corrupt practices and HLL will commit to prevent corruption, in any form, by its officials by following transparent procedures.

The parties hereto hereby agree to enter into this Integrity Pact and agree as follows:

Clause.1. Commitments of HLL

- 1.1 HLL undertakes that HLL and /or its Associates (i.e. employees, agents, consultants, advisors, etc.) will not demand, take a promise for or accept, directly or through intermediaries, any bribe, consideration, gift, reward, favour or any material or immaterial benefit or any other advantage from the BIDDER(S), either for themselves or for any person, organization or third party related to the contract in exchange for an advantage in the bidding process, bid evaluation, contracting or implementation process related to the contract.
- 1.2 HLL will, during the tender process / pre-contract stage, treat all Bidder(s) with equity and reason, and will provide to all Bidder(s) the same information and will not provide any such information or additional information, which is confidential in any manner, to

any particular BIDDER(S) which could afford an advantage to that particular BIDDER(S) in comparison to other Bidder(s) in relation to tendering process or during the contract execution.

- 1.3 All the officials of HLL will report to Chief Vigilance Officer of HLL (CVO), any attempted or completed breaches of the above commitments as well as any substantial suspicion of such a breach.
- 1.4 HLL will exclude from the process all known prejudiced persons and persons who would be known to have a connection or nexus with the prospective Bidder(s).
- 1.5 If the BIDDER(S) reports to HLL with full and verifiable facts any misconduct on the part of HLL's Associates (i.e. employees, agents, consultants, advisors, etc.) and the same is prima facie found to be correct by HLL, necessary disciplinary proceedings, or any other action as deemed fit, including criminal proceedings may be initiated by HLL. Further, such an Associate may be debarred from further dealings related to the contract process. In such a case, while an enquiry is being conducted by HLL the proceedings under the contract would not be stalled.

Clause 2. Commitments of Interested Bidder(s)/ CONTRACTORS

2. The INTERESTED BIDDER(S) commits itself to take all measures necessary to prevent corrupt practices, unfair means and illegal activities during any stage of its bid or during any pre-contract or post-contract stage in order to secure the contract or in furtherance to secure it and in particular commit itself to the following:-
 - 2.1 The INTERESTED BIDDER(S) will not offer, directly or indirectly (i.e. employees, agents, consultants, advisors, etc.) any bribe, gift, consideration, reward, favour, any material or immaterial benefit or other advantage, commission, fees, brokerage or inducement to any official of HLL, connected directly or indirectly with the bidding process, or to any person, organization or third party related to the contract in exchange for any advantage in the bidding, evaluation, contracting and implementation of the contract.
 - 2.2 The INTERESTED BIDDER(S) further undertakes that it has not given, offered or promised to give, directly or indirectly any bribe, gift, consideration, reward, favour, any material or immaterial benefit or other advantage, commission, fees, brokerage or inducement to any official of HLL or otherwise in procuring the contract or forbearing to do or having done any act in relation to obtaining or execution of the contract or any other contract with the Government for showing or forbearing to show favour or disfavor to any person in relation to the contract or any other contract with the Government.
 - 2.3 The INTERESTED BIDDER(S) will not engage in collusion, price fixing, cartelization, etc. with other counterparty(s).
 - 2.4 The counterparty will not pass to any third party any confidential information entrusted to it, unless duly authorized by HLL.
 - 2.5 The counterparty will promote and observe ethical practices within its Organization and its affiliates.
 - 2.6 INTERESTED BIDDER(S) shall disclose the name and address of agents and representatives and Indian BIDDER(S) shall disclose their Overseas principals or associates.
 - 2.7 The counterparty will not make any false or misleading allegations against HLL or its Associates.
 - 2.8 INTERESTED Bidder(s) shall disclose the payments to be made by them to agents / brokers or any other intermediary, in connection with this bid/contract.

- 2.9 The INTERESTED BIDDER(S) further confirms and declares to HLL that the BIDDER(S) is the original integrator / manufacturer /authorized government sponsored export entity of the defense stores and has not engaged any individual or firm or company whether Indian or Overseas to intercede, facilitate or in any way to recommend to HLL or any of its functionaries, whether officially or unofficially to award the contract to the BIDDER(S), nor has any amount been paid, promised or intended to be paid to any such individual, firm or company in respect of any such intercession, facilitation or recommendation.
- 2.10 The INTERESTED BIDDER(S) while presenting the bid or during pre-contract negotiations or before signing the contract, shall disclose any payments he has made, is committed to or intends to make to officials of HLL or their family members, agents, brokers or any other intermediaries in connection with the contract and the details of services agreed upon for such payments.
- 2.11 The INTERESTED BIDDER(S) will not accept any advantage in exchange for any corrupt practice, unfair means and illegal activities.
- 2.12 The INTERESTED BIDDER(S) commits to refrain from giving any complaint directly or through any other manner without supporting it with full and verifiable facts.
- 2.13 If the INTERESTED BIDDER(S) or any employee of the INTERESTED BIDDER(S) or any person acting on behalf of the BIDDER(S), either directly or indirectly, is a relative of any of the officers of HLL, or alternatively, if any relative of an officer of HLL has financial interest /stake in the BIDDER(S)'s firm, the same shall be disclosed by the BIDDER(S) at the time of filing of tender.
- The term 'relative' for this purpose would be as defined in Section 6 of the Companies Act 1956.
- 2.14 The INTERESTED BIDDER(S) shall not lend to or borrow any money from or enter into any monetary dealings or transactions, directly or indirectly, with any employee of HLL.
- 2.15 The INTERESTED BIDDER(S) will not collude with other parties interested in the contract to impair the transparency, fairness and progress of the bidding process, bid evaluation, contracting and implementation of the contract, and will not enter into any undisclosed agreement or understanding with other Bidder(s), whether formal or informal. This applies in particular to prices, specifications, certifications, subsidiary contracts, submission or non-submission of bids or any other actions to restrict competitiveness or to introduce cartelization in the bidding process.
- 2.16 The INTERESTED BIDDER(S) will not commit any offence under the relevant Indian Penal Code, 1860 or Prevention of Corruption Act, 1988; further the Bidder(s)/ Contractor(s) will not use improperly, for purposes of competition or personal gain, or pass on to others, any information or document provided by the HLL as part of the business relationship, regarding plans, technical proposals and business details, including information contained or transmitted electronically. The BIDDER(S) also undertakes to exercise due and adequate care lest any such information is divulged.
- 2.17 The INTERESTED BIDDER(S) will not instigate third persons to commit offences outlined above or be an accessory to such offences.
- 2.18 The Interested Bidder(s)/Contractors(s) of Overseas origin shall disclose the name and address of the Agents /representatives in India, if any. Similarly the Bidder(s) /Contractors(s) of Indian Nationality shall furnish the name and address of the Overseas Principal(s), if any.

Clause.3. Previous contravention and Disqualification from tender process and exclusion from future contracts

- 3.1 The INTERESTED BIDDER(S) declares that no previous contravention occurred in the last three years immediately before signing of this Integrity Pact, with any other company in any country in respect of any corrupt practices envisaged hereunder or with any Public Sector Enterprise in India or any Government Department in India that could justify BIDDER(S)'s exclusion from the tender process
- 3.2 The BIDDER(S) agrees that if it makes incorrect statement on this subject, BIDDER(S) can be disqualified from the tender process or the contract, if already awarded, can be terminated for such reason.

If BIDDER(S) before award or during execution has committed a contravention through a violation of Clause 2, above or in any other form such as to put his reliability or credibility in question, HLL is entitled to disqualify the BIDDER(S) from the tender process.

Clause .4. Equal treatment of all Bidder(s) / Contractors /

Subcontractors

- 4.1 The Bidder(s) / Contractor(s) undertake(s) to demand from his Subcontractors a commitment in conformity with this Integrity Pact.
- 4.2 HLL will enter into agreements with identical conditions as this one with all Bidder(s) and Contractors.
- 4.3 HLL will disqualify from the tender process all Bidder(s) who do not sign this Pact or violate its provisions.

Clause .5. Consequences of Violation / Breach

- 5.1 Any breach of the aforesaid provision by the INTERESTED BIDDER(S) or any one employed by it or acting on its behalf (whether with or without the knowledge of the BIDDER(S)) shall entitle HLL to take all or any one of the following action, wherever required:-
 - i. To immediately call off the pre-contract negotiations without assigning any reason or giving any compensation to the BIDDER(S). However, the proceedings with the other
 - ii. If INTERESTED BIDDER(S) commits violation of Integrity Pact Policy during bidding process, he shall be liable to compensate HLL by way of liquidated damages amounting to a sum equivalent to 5% to the value of the offer or the amount equivalent to Earnest Money Deposit /Bid Security, whichever is higher.
 - iii. In case of violation of the Integrity Pact after award of the contract, HLL will be entitled to terminate the contract. HLL shall also be entitled to recover from the contractor liquidated damages equivalent to 10% of the contract value or the amount equivalent to security deposit/ performance guarantee, whichever is higher.
 - iv. To immediately cancel the contract, if already signed, without giving any compensation to the BIDDER(S).
 - v. To recover all sums already paid by HLL, and in case of an Indian BIDDER(S) with interest thereon at 2% higher than the prevailing Prime Lending Rate of State Bank of India, while in case of a BIDDER(S) from a country other than India with interest thereon at 2% higher than the LIBOR. If any outstanding payment is due to the BIDDER(S) from HLL in connection with any other contract for any other stores, such outstanding payment could also be utilized to recover the aforesaid amount.
 - vi. To encash the advance bank guarantee and performance guarantee / warranty bond, if furnished by the BIDDER(S), in order to recover the payments already made by HLL, along with interest.
 - vii. To cancel all or any other contract with the INTERESTED BIDDER(S). The BIDDER(S) shall be liable to pay compensation for any loss or damage to HLL resulting from such

cancellation/recession and HLL shall be entitled to deduct the amount so payable from the money(s) due to the BIDDER(S).

- viii. To debar the INTERESTED BIDDER(S) from participating in future bidding processes of HLL for a minimum period of five (5) years, which may be further extended at the discretion of HLL or until Independent External Monitors is satisfied that the Counterparty will not commit any future violation.
 - ix. To recover all sums paid in violation of this Pact by INTERESTED BIDDER(S) to any middleman or agent or broker with a view to securing the contract.
 - x. In cases where irrevocable Letters of credit have been received in respect of any contract signed by HLL with the INTERESTED BIDDER(S), the same shall not be opened.
 - xi. Forfeiture of performance guarantee in case of a decision by HLL to forfeit the same without assigning any reason for imposing sanction for violation of the pact.
- 5.2 HLL will be entitled to all or any of the actions mentioned in para 5.1(i) to (x) of this pact also on the commission by the BIDDER(S) or any one employed by it or acting on its behalf (whether with or without the knowledge of the BIDDER(S)), of an offence as defined in Chapter IX of the Indian Penal Code, 1860 or Prevention of Corruption Act, 1988 or any other statute enacted for prevention of corruption.
- 5.3 The decision of HLL to the effect that a breach of the provisions of this Pact has been committed by the INTERESTED BIDDER(S) shall be final and conclusive on the BIDDER(S). However, the BIDDER(S) can approach the Independent External Monitor(s) appointed for the purposes of this Pact.

Clause.6. Fall Clause

The INTERESTED BIDDER(S) undertakes that it has not supplied/is not supplying similar product/systems or subsystems OR providing similar services at a price / charge lower than that offered in the present bid in respect of any other Ministry/Department of the Government of India or PSU and if it is found any stage that similar product/systems or sub systems was supplied by the BIDDER(S) to any to the Ministry/Department of the Government of India or a PSU at a lower price, then that very price, with due allowance for elapsed time will be applicable to the present case and the difference in the cost would be refunded by the BIDDER(S) to HLL, if the contract has already been concluded.

Clause .7. Independent External Monitor(s)

- 7.1 HLL has appointed Independent External Monitor(s) (hereinafter referred to as Monitor(s)) for this Pact in consultation with the Central Vigilance Commission.
- 7.2 The responsibility of the Monitor(s) shall be to review independently and objectively, whether and to what extent the parties comply with the obligations under this Pact.
- 7.3 The Monitor(s) shall not be subject to instructions by the representatives of the parties and perform their functions neutrally and independently.
- 7.4 Both the parties accept that the Monitor(s) have the right to access all the documents relating to the project/ procurement, including minutes of meetings.
- 7.5 As soon as the Monitor(s) notices, or has reason to believe, a violation of this pact, he will so inform the CVO.
- 7.6 The INTERESTED BIDDER(S) accepts that the Monitor(s) have the right to access without restriction to all project documentation of HLL including that provided by the BIDDER(S). The BIDDER(S) will also grant the Monitor(s), upon his request and demonstration of a valid interest, unrestricted and unconditional access to his project documentation. The same is applicable to subcontractors engaged by the BIDDER(S).

The Monitor(s) shall be under contractual obligation to treat the information and documents of the BIDDER(S)/ Subcontractor(s) with confidentiality.

- 7.7 HLL will provide to the Monitor(s) sufficient information about all meetings among the parties related to the Project provided such meeting could have an impact on the contractual relation between the parties. The parties will offer to the Monitor(s) option to participate in such meetings.
- 7.8 The Monitor(s) will submit a written report to the CVO of HLL within 8 to 10 weeks from the date of reference or intimation to him by HLL/BIDDER(S) and, should consent arise, submit proposals for correcting problematic situations.

Clause.8.Criminal charges against violating Bidder(s)/

Contractor(s)/ Subcontractor(s)

If HLL obtains knowledge of conduct of a Bidder(s), Contractor or Subcontractor, or of an employee or a representative or an associate of a Bidder(s), Contractor or Subcontractor which constitutes corruption, or if HLL has substantive suspicion in this regard, HLL will inform the same to the Chief Vigilance Officer.

Clause.9. Facilitation of Investigation

In case of any allegation of violation of any provisions of this Pact or payment of commission, HLL or its agencies shall be entitled to examine all the documents, including the Books of Accounts of the BIDDER(S) and the BIDDER(S) shall provide necessary information and documents in English and shall extend all possible help for the purpose of such examination.

Clause.10. Law and Place of Jurisdiction

Both the Parties agree that this Pact is subject to Indian Law. The place of performance and hence this Pact shall be subject to Thiruvananthapuram Jurisdiction.

Clause.11. Other legal Actions

The actions stipulated in the Integrity Pact are without prejudice to any other legal action that may follow in accordance with the provisions of the extant law in force relating to any civil or criminal proceedings.

Clause.12. Validity and Duration of the Agreement

This Pact begins when both parties have legally signed it. It expires for the Contractor/Successful Bidder(s) 12 months after the last payment under the contract or the complete execution of the contract to the satisfaction of the both HLL and the BIDDER(S) /Seller, including warranty period, whichever is later, and for all other Bidder(s)/unsuccessful Bidder(s) 6 months after the contract has been awarded.

If any claim is made / lodged during this time, the same shall be binding and continue to be valid despite the lapse of this pact as specified above, unless it is discharged / determined by Chairman and Managing Director of HLL.

Clause. 13. Other provisions

- 13.1 Changes and supplements as well as termination notices need to be made in writing. Both the Parties declare that no side agreements have been made to this Integrity Pact.
- 13.1 If the Contractor is a partnership or a consortium, this agreement must be signed by all partners or consortium members.
- 13.1 Should one or several provisions of this agreement turn out to be invalid, the remainder of this agreement remains valid. In this case, the parties will strive to come to an agreement to their original intentions

INWITNESS THEREOF the parties have signed and executed this pact at the place and date first above mentioned in the presents of following witnesses:

HLL

Mr K.Beji George

Chairman and Managing Director

HLL Lifecare Limited,

Thiruvananthapuram.

Witness

1.....

2.....

BIDDER(S)

(Name & Designation)

Witness

1.....

2.....

* Provisions of these clauses would be amended /deleted in line with the policy of HLL in regard to involvement of Indian agents of Overseas suppliers.